

**ALGEBRA**  
**OF**  
**FLOWNOMIALS**

Part 1

Binary Flownomials; Basic Theory

Gheorghe Ștefănescu  
Institute of Mathematics, Romanian Academy  
P.O. Box 1-764, RO - 70700, Bucharest, Romania  
email: [ghstef@imar.ro](mailto:ghstef@imar.ro)

# Foreward

Kleene's calculus of regular expressions and the associated regular algebra describe in an elegant way cyclic processes with global states. This calculus has a deep mathematical theory and many applications to sequential programs, automata, formal languages, circuits, etc. but less in parallel/distributed computation.

We present the “calculus of flownomials” that may be seen as an extension of the above calculus to cope with processes having multiple entries and multiple exits, i.e., pins for connections. Each pin may be seen as a local state and—in our view—this makes the extension well-suited for distributed computation. Technically, the main ingredient is a new axiomatic looping operation, called “feedback”; it connects an output to an input and then both pins are hidden.

This new setting allows for *a simple algebra for flowgraphs modulo graph isomorphism*. We claim that whenever a cyclic process is implicitly or explicitly present, a semantic algebra as above may be constructed.

On top of this algebra one may add simple axioms to cope with correct and complete axiomatizations for certain classical equivalences, e.g., the equivalences associated to the input behaviour, bisimulation or the input-output behaviour. The so called “enzymatic rule” which produces these complete axiomatisations is a rule to reason in a cyclic environment.

\* \* \*

In this first part we present the kernel of the calculus of binary flownomials.

Complete proofs are given for all the results, except for some commuting lemmas used in Chapter 11 which may be found in [Ste87b] and for which I have no better proofs.

A few references are included.

More references and connections with related topics, applications, particular models and equivalent presentations for various algebraic structures used in this calculus will be included in the second part.

# Contents

<b>1</b>	<b>Introduction</b>	<b>5</b>
1.1	The calculus of regular expressions . . . . .	5
1.2	Iteration theories . . . . .	6
1.3	The calculus of flownomials . . . . .	6
1.4	Basic results . . . . .	8
1.5	Acknowledgements . . . . .	11
<b>I</b>	<b>Acyclic Structures</b>	<b>12</b>
<b>2</b>	<b>Relations and <math>xy</math>-ssmc's</b>	<b>13</b>
2.1	Short presentation of the results . . . . .	13
2.2	Bijections ( $a\alpha$ -IRel $_S$ ) and symmetric strict monoidal categories (ssmc's) . .	19
2.3	Normal form of relations . . . . .	24
2.4	A universal theorem for $xy$ -IRel $_S$ . . . . .	30
2.5	The analysis of conditions IP1–IP4 . . . . .	34
2.6	Classes of relations $xy$ -IRel $_S$ as enriched ssmc's . . . . .	38
2.7	Short comments and references . . . . .	39
<b>3</b>	<b>Critical acyclic structures (strong <math>xy</math>-ssmc's)</b>	<b>40</b>
3.1	Strong $xy$ -ssmc's . . . . .	40
3.2	Algebraic theories ( $a\delta$ -strong ssmc's) . . . . .	42
3.3	Matrix theories ( $a\delta$ - and $d\alpha$ -strong ssmc's) . . . . .	42
3.4	Short comments and references . . . . .	45
<b>II</b>	<b>Algebra of Cyclic Flowgraphs</b>	<b>46</b>
<b>4</b>	<b>Flowgraphs and <math>a\alpha</math>-flownomials</b>	<b>47</b>
4.1	Short presentation of relations with feedback . . . . .	47
4.2	Flownomial expressions; $a\alpha$ -Flow-Calculus . . . . .	49
4.2.1	Defining flownomial expressions and $a\alpha$ -Flow-Calculus. . . . .	49
4.2.2	Graphical interpretation . . . . .	51
4.2.3	The meaning of $a\alpha$ -Flow-Calculus . . . . .	51
4.2.4	Example . . . . .	53
4.3	Flownomial expressions over abstract connecting theories . . . . .	53
4.4	Structure of $a\alpha$ -flow . . . . .	55
4.5	Short comments and references . . . . .	57

<b>5</b>	<b>Algebra of flowgraphs (<math>a\alpha</math>-flow)</b>	<b>58</b>
5.1	A canonical representation of flowgraphs . . . . .	58
5.1.1	The normal form representation . . . . .	58
5.1.2	Relating different normal form representations . . . . .	60
5.2	Correctness of $a\alpha$ -Flow-Calculus . . . . .	61
5.2.1	An equivalent presentation for $a\alpha$ -flow. . . . .	61
5.2.2	Flowgraphs as isomorphic normal form expressions; algebra $\mathbb{F}\ell_{a\alpha}[X, T]$	64
5.2.3	Extending $a\alpha$ -flow structure from connections to flowgraphs . . . . .	67
5.2.4	General composition on normal form expressions . . . . .	70
5.2.5	Example of computation using normal forms . . . . .	71
5.3	Completeness of $a\alpha$ -Flow-Calculus . . . . .	72
5.3.1	Bringing expressions to normal form . . . . .	72
5.3.2	Simulation rule . . . . .	74
5.3.3	Deduction of the normalisation and simulation rules from the rules of $a\alpha$ -Flow-Calculus . . . . .	74
5.3.4	Completeness of the axiom system . . . . .	77
5.4	Meaning and universality of $a\alpha$ -flownomials . . . . .	77
5.5	Short comments and references . . . . .	78
<b>6</b>	<b>Graph isomorphism with various constants</b>	<b>79</b>
6.1	Axiomatising relations with feedback . . . . .	79
6.2	Algebra of flowgraphs with various constants ( $xy$ -ssmc with feedback) . . . . .	83
6.3	Short comments and references . . . . .	83
<b>III</b>	<b>Algebras of Flowgraph Behaviours</b>	<b>84</b>
<b>7</b>	<b>Flowgraph behaviours; general facts</b>	<b>85</b>
7.1	Enzymatic rule . . . . .	85
7.1.1	The rôle of the enzymatic rule . . . . .	85
7.1.2	Validity of the enzymatic rule in some semantic domains . . . . .	88
7.1.3	Generating congruences in algebras with conditional equations . . . . .	89
7.1.4	Extending $xy$ -strong axioms . . . . .	90
7.2	$xy$ -flow . . . . .	92
7.3	Simulation . . . . .	93
7.3.1	Examples . . . . .	93
7.3.2	Definition; general properties . . . . .	93
7.3.3	Duality . . . . .	100
7.4	Short comments and references . . . . .	101
<b>8</b>	<b>Deterministic one-way behaviour (<math>a\delta</math>-flow)</b>	<b>102</b>
8.1	Characterization theorem $\overset{a\delta}{\leftarrow\rightleftarrows}$ ; ( $\overset{a\delta}{\leftarrow\rightleftarrows}$ -minimization) . . . . .	102
8.2	The input behaviour . . . . .	108
8.3	Correctness of $a\delta$ -Flow-Calculus . . . . .	109
8.3.1	Extending $a\delta$ -flow structure form $T$ to $\mathbb{F}\ell_{a\delta}[X, T]$ . . . . .	109
8.3.2	Correctness Theorem . . . . .	111
8.4	Completeness of $a\delta$ -Flow-Calculus with respect to the input behaviour . . . . .	111
8.5	Universality of $a\delta$ -flownomials . . . . .	111

8.6	The dual version: output behaviour ( $d\alpha$ -flow)	112
8.7	Short comments and references	112
<b>9</b>	<b>Nondeterministic one-way behaviour</b>	<b>113</b>
9.1	Axiomatising bisimilar flowgraphs	113
9.2	Short comments and references	114
<b>10</b>	<b>Deterministic I–O behaviours (<math>b\delta</math>-flow)</b>	<b>115</b>
10.1	Characterization theorem for $\xleftrightarrow{b\delta}$ ; ( $\xleftrightarrow{b\delta}$ -minimization)	115
10.2	Correctness of $b\delta$ -Flow-Calculus	123
10.3	Completeness of $b\delta$ -Flow-Calculus with respect to the deterministic input-output behaviour	124
10.4	Universality of $b\delta$ -flownomials	125
10.5	Short comments and references	125
<b>11</b>	<b>Nondeterministic I–O behaviours (<math>d\delta</math>-flow)</b>	<b>126</b>
11.1	Characterization theorem for the equivalence $\xleftrightarrow{d\delta}$ generated by simulation via relations	126
11.2	Correctness of $d\delta$ -Flow-Calculus with respect to the nondeterministic input-output behaviour	132
11.3	Completeness of $d\delta$ -Flow-Calculus with respect to the nondeterministic input-output behaviour	132
11.3.1	Reduction of nondeterministic flowgraphs to semideterministic ones	133
11.3.2	Formalisation of the input-output behaviour	137
11.3.3	Reduction of semideterministic flowgraphs to deterministic ones	140
11.3.4	Completeness theorem	144
11.4	Universality of $d\delta$ -flownomials	145
11.5	Short comments and references	145
<b>**</b>	<b>Bibliography</b>	<b>156</b>
<b>12</b>	<b>Appendix: Two presentations for <math>a\alpha</math>-flow</b>	<b>151</b>
<b>13</b>	<b>Appendix: The axioms</b>	<b>156</b>

# Chapter 1

## Introduction

### 1.1 The calculus of regular expressions

A basic calculus for sequential computation is provided by Kleene's *calculus of regular expressions*. It has a simple syntax and semantics. The set  $Exp(X)$  of regular expressions over  $X$  is given by

$$E ::= E \oplus E | E \cdot E | E^* | 0 | 1 | x (x \in X)$$

The expressions are interpreted as set of strings, the operations as 'union', 'catenation' and 'iterated catenation' and the constants as 'empty set' and 'empty string', respectively.

This calculus is a basic calculus for sequential computation and has a broad range of applications in the design and analysis of circuits and programming languages, study of automata and grammars, analysis of flowchart schemes, semantics of programming languages, etc.

One may wonder why such a basic calculus for sequential computation has so little influence in the actual development of the distributed computation.<sup>1</sup> The reason, I think, lays in one more operation used by the calculus of regular expressions which is often hidden by the above simple syntax and semantics. In order to handle complex objects like automata, grammars, circuits, etc. one adds to the above syntax a *matrix building operator*: if  $a_{ij}, i \in [m], j \in [n]$  are expressions, then the matrix  $(a_{ij})$  specifies the behaviour of a complex object with  $m$  inputs and  $n$  outputs. By changing the point of view from 'elements' to such 'complex objects', one may see that the above construction is based on the following restriction.

Hypothesis: "If  $f : m \rightarrow n$  is a black box with  $m$  inputs and  $n$  outputs and  $f_{ij}$ , for  $i \in [m], j \in [n]$  denotes the restriction of  $f$  to its  $i$ -th input and  $j$ -th output, then the behaviour of  $f$  is uniquely given by the behaviour of the restrictions  $f_{ij}$  to one input and one output."

This is a very strong restriction and it makes the calculus unsuited to be used for distributed computation.

---

<sup>1</sup>Process algebra for concurrency inherits some features of this calculus, but it deals with a different behavioral meaning and both the regular algebras and the regular expressions are not preserved as particular instances of this more general theory.

## 1.2 Iteration theories

An algebraic setting in between regular and flownomial algebras is provided by the algebraic theories of flowchart schemes or dataflow networks. In such a case a weaker hypothesis of the following type may be used:<sup>2</sup>

Hypothesis: “If  $f : m \rightarrow n$  is a black box with  $m$  inputs and  $n$  outputs and  $f_i$ , for  $i \in [m]$  denotes the restriction of  $f$  to its  $i$ -th input (all the outputs being kept present), then the behaviour of  $f$  is uniquely given by the behaviour of the restrictions  $f_i$  to one input.”

The resulting algebraic theories are more general than regular algebras and are useful to study certain semantic models, but they fail to produce a simple syntactic model similar to Kleene’s model of regular expressions.

## 1.3 The calculus of flownomials

We present below the *calculus of flownomials* which may be seen as an extension of the calculus of regular expressions to the case the atoms we use have many-inputs and many-outputs. We hope this extension will play a similar rôle for the distributed computation as the classical regular calculus is playing for the sequential computation.

The calculus of (binary) flownomials is an abstract calculus that models flowgraphs (= labelled directed hypergraphs) and their behaviours. It starts with two families of doubly-ranked elements: a family of variables  $X = \{X(a, b)\}_{a, b \in M}$  (these variables denote “black boxes”, i.e. atomic elements with two types of connecting ports) and an abstract structure  $T = \{T(a, b)\}_{a, b \in M}$  (these elements model the messages that are transmitted via the connecting channels); — Here  $M = (M, \oplus, 0)$  is a monoid modelling the strings of input and output ports. We also use the functions  $i : \dots \rightarrow M$  and  $o : \dots \rightarrow M$  that give the corresponding strings of the inputs and outputs, respectively.

The syntax of the calculus of binary flownomials is given by the following constants and operations. The set  $Exp(X)$  of flownomial expressions is given by:

$$E ::= E \oplus E \mid E \cdot E \mid E \uparrow^c \mid \wedge_m^a \mid^a \mathbf{X}^b \mid \vee_a^n \mid x \in X)^3$$

where  $a, b, c \in M$  and  $m, n \in \mathbb{N}$ . Their rôle is explained below.

The collection of *flownomial expressions* is obtained starting with the elements in  $X$  and  $T$  and applying three operations: *sum* (or parallel composition) “ $\oplus$ ”, *composition* (i.e. sequential composition) “ $\cdot$ ” and *feedback* “ $\uparrow^c$ ”, for  $c \in M$ . The sum  $f \oplus g$  is always defined and  $i(f \oplus g) = i(f) \oplus i(g)$  and  $o(f \oplus g) = o(f) \oplus o(g)$ . The composite  $f \cdot g$  is defined only in the case  $o(f) = i(g)$  and, in such a case,  $i(f \cdot g) = i(f)$  and  $o(f \cdot g) = o(g)$ . The feedback  $f \uparrow^c$  is defined only in the case  $i(f) = a \oplus c$  and  $o(f) = b \oplus c$ , for some  $a, b \in M$  and, in such a case,  $i(f \uparrow^c) = a$  and  $o(f \uparrow^c) = b$ . The *acyclic case* refers to the case without feedback.

<sup>2</sup>In this form the hypothesis fits the models of flowchart schemes. The case of dataflow models is dual: a many-outputs component is a tuple of single-output ones.

<sup>3</sup>The regular expression setting is a particular instance of this one, namely:  $M = \mathbb{N}$  and  $0 = \wedge_0^1 \cdot \vee_1^0$ ,  $1 := \wedge_1^1 (= \vee_1^1)$ ,  $f + g := \wedge_2^1 \cdot (f \oplus g) \cdot \vee_1^2$ ,  $f \cdot g := f \cdot g$ ,  $f^* := [\vee_1^2 \cdot (1 \oplus f) \cdot \wedge_2^1] \uparrow^1$ .

The support theory for connections  $T$  should “contain” a certain class of finite binary relations. A few classes used below are  $\mathbb{F}n$  (finite functions),  $\mathbb{P}fn$  (partially defined finite functions) and  $\mathbb{R}el$  (arbitrary finite relations). At the abstract level this means that we should have some constants that model/axiomatise these relations. The collection of constants we use for this purpose is: *(block) ramification*  $\wedge_m^a$ , *(block) transposition*  ${}^a\mathbf{X}^b$ , and *(block) identification*  $\vee_a^n$ , where  $m, n \in \mathbb{N}$  and  $a, b \in M$ . Each of the above classes of relations (and 13 other classes) may be generated using certain subcollections of these constants only. To specify them we use the notation  $xy$ , where  $x \in \{a, b, c, d\}$  and  $y \in \{\alpha, \beta, \gamma, \delta\}$ . Restriction  $x = a$  means the constants of the type  $\wedge_m^a$  always have  $m = 1$ ; restriction  $x = b$ , means  $m \leq 1$ ;  $x = c$ , means  $m \geq 1$ ; and  $x = d$  means no restriction (arbitrary  $m$ ). Restriction  $y$  is defined in a similar manner, using  $n$  of the constants  $\vee_a^n$  and the corresponding Greek letters. For example, restriction  $a\delta$  refers to functions ( $\mathbb{F}n$ ), restriction  $b\delta$  to partially defined functions ( $\mathbb{P}fn$ ) and  $d\delta$  to relations ( $\mathbb{R}el$ ).

For flownomials we may single out certain abstract algebraic structures to play the rôle the ring structure is playing for polynomials. The critical axioms used to define them are:

- (*commutation of the composition of the constants to the other elements*)

$$\begin{aligned} f \cdot \wedge_m^b &= \wedge_m^a \cdot (mf) \\ {}^a\mathbf{X}^c \cdot (g \oplus f) &= (f \oplus g) \cdot {}^b\mathbf{X}^d \\ \vee_a^n \cdot f &= (nf) \cdot \vee_b^n \end{aligned}$$

where  $f : a \rightarrow b$ ,  $g : c \rightarrow d$  and where  $kf$  denotes the  $k$ -times summation  $f \oplus \dots \oplus f$ . This axiom scheme is used in two ways:

- the *strong* version is the one where the elements  $f$ ,  $g$  above are arbitrary,
  - the *weak* version is the one where it is applied only for some ground terms  $f$ ,  $g$ .<sup>4</sup>
- (*enzymatic axiom for the looping operation*)

$$f \cdot (l_b \oplus z) = (l_a \oplus z) \cdot g \quad \text{implies} \quad f \uparrow^c = g \uparrow^d$$

where  $z : c \rightarrow d$  is an abstract relation and  $f : a \oplus c \rightarrow b \oplus c$ ,  $g : a \oplus d \rightarrow b \oplus d$  are arbitrary elements.<sup>5</sup>

Roughly speaking:

- an *xy-ssmc* (*xy-symmetric strict monoidal category*) is the acyclic structure defined using the strong commutation for transpositions  ${}^a\mathbf{X}^b$  and the weak commutation for the other constants;
- in a *strong xy-ssmc* all the constants corresponding to  $xy$  obey the strong commutation axioms;

---

<sup>4</sup> *Ground terms* or *abstract relations* mean terms written with the given operations and certain constants in  $\wedge_m^a$ ,  ${}^a\mathbf{X}^b$ ,  $\vee_a^n$ ; *xy-terms* or *abstract xy-relations* refer to terms written using the constants fulfilling the restriction  $xy$  only.

<sup>5</sup> The equalities given by the first equation clearly refer to acyclic processes. This enzymatic axiom allows them to be used in a cyclic environment.



- finally, an *xy-flow* is a strong *xy-ssmc* that obeys the enzymatic axiom whenever  $z$  is an abstract *xy*-relation.

A large number of algebraic structures may be obtained by choosing the constants and certain weak, strong or enzymatic axioms. This freedom gives flexibility to the calculus which is well-suited to model various kind of flowgraphs and equivalences. A few basic cases will be presented below.

Polynomials are classes of equivalent polynomial expressions. In a similar manner, *flownomials* are defined as classes of equivalent flownomial expressions under an appropriate relation of equivalence. Moreover, in both calculi there are two equivalent ways to introduce the standard equivalences: (1) by using the rules of the algebra, or (2) by using normal form representations.

For the first way, the standard equivalence  $\sim_{xy}$  on flownomial expressions may be introduced as the equivalence generated by the commutation of *xy*-constants with variables in the class of equivalence relations fulfilling the enzymatic rule.<sup>6</sup>

The second equivalent way to define the equivalence  $\sim_{xy}$  is to use the *normal form flownomial expressions*; such an expression over  $X$  and  $T$  is of the following type:

$$((l_a \oplus x_1 \oplus \dots \oplus x_k) \cdot f) \uparrow^{i(x_1) \oplus \dots \oplus i(x_k)}$$

with  $f : a \oplus o(x_1) \oplus \dots \oplus o(x_k) \rightarrow b \oplus i(x_1) \oplus \dots \oplus i(x_k)$  in  $T$  and  $x_1, \dots, x_k$  in  $X$ . Each flownomial expression may be reduced to a unique normal form. Two normal form flownomial expressions  $F = ((l_a \oplus x_1 \oplus \dots \oplus x_m) \cdot f) \uparrow^{i(x_1) \oplus \dots \oplus i(x_m)}$  and  $G = ((l_a \oplus y_1 \oplus \dots \oplus y_n) \cdot g) \uparrow^{i(y_1) \oplus \dots \oplus i(y_n)}$  are *similar* via a relation  $r \in \mathbb{R}\text{el}(m, n)$  iff

- (i)  $(i, j) \in r \Rightarrow x_i = y_j$ ;
- (ii)  $f \cdot (l_b \oplus i(r)) = (l_a \oplus o(r)) \cdot g$ .

where  $i(r)$  (resp.  $o(r)$ ) represents the “block” extension of  $r$  to inputs (resp. outputs).

Below,  $\mathbb{F}\ell_{xy}[T, X]$  denotes the algebra of  $\sim_{xy}$ -equivalent flownomials over  $X$  and  $T$ .

## 1.4 Basic results

The main results in the calculus of flownomials are of the following type:

**Theorem 1.1 (Expressivness Theorem)** *Various classes of flowgraphs are represented by flownomial expressions over an appropriate class of connecting theory, for example:*

- *The usual nondeterministic (resp: deterministic; or partial and deterministic, etc.) flowgraphs with atoms in  $X$  are represented by flownomials over  $\mathbb{R}\text{el}$  (resp:  $\mathbb{F}\text{n}$ ;  $\mathbb{P}\text{fn}$ , etc.) and  $X$ .*
- *Flowgraphs having connecting channels that pass values in a set  $D$  are represented by flownomials over substructures in  $\mathbb{R}\text{el}(D)$ .*

---

<sup>6</sup>This means, if two terms as in the premise of the enzymatic axiom are equivalent, then the corresponding terms in the conclusion of the enzymatic axiom are equivalent, too.

- Higher order processes are represented by flownomials over other flownomials.

**Theorem 1.2 (Axiomatisations)** *Subsets of the axioms presented in Appendix 13 give correct and complete axiomatisations for the classes of equivalent flowgraphs with respect to various natural equivalence relations. For example:*

- **graph-isomorphism (case  $a\alpha$ -strong)**

*A correct and complete axiomatization for flowgraphs modulo graph isomorphism consists of the axioms defining an  $a\alpha$ -flow,<sup>7</sup> where*

$$a\alpha\text{-flow} = B1\text{--}B10 + R1\text{--}R5 + F1\text{--}F2.$$

- **graph-isomorphism with various constants (case  $a\alpha$ -strong +  $xy$ -weak)**

*The axiomatisation of flowgraphs with various constants (at the syntactic level) modulo isomorphism is provided by the axioms defining an  $xy$ -ssmc with feedback, where*

$$xy\text{-ssmc with feedback} = a\alpha\text{-flow} + \text{all the axioms in } A1\text{--}A19 \text{ and } F1\text{--}F5 \text{ described using constants of type } \hat{x}\hat{y} \text{ only}$$

*where  $\hat{x}\hat{y}$  is the restriction containing  $xy$  and closed to the feedback operation.<sup>8</sup>*

- **input (or one-way) behaviour, deterministic case (case  $a\delta$ -strong)**

*The axioms of  $a\delta$ -flow, i.e.*

$$a\delta\text{-flow} = b\delta\text{-ssmc with feedback} + S1\text{--}S2 + \text{Enz}_{\text{functions}}$$

*give a correct and complete axiomatization for the classes of deterministic flowgraphs that have the same step-by-step computation sequences (or equivalently, they unfold into the same tree).*

- **input behaviour, nondeterministic case (case  $a\delta$ -strong +  $d\delta$ -weak)**

*The axioms of*

$$a\delta\text{-flow over a } d\delta\text{-ssmc with feedback}$$

*give a correct and complete axiomatization for the classes of nondeterministic flowgraphs with single-input/single-output atoms modulo bisimulation.*

- **input-output (or two-way) behaviour, deterministic case (case  $b\delta$ -strong)**

*The axioms of  $b\delta$ -flow, i.e.*

$$b\delta\text{-flow} = b\delta\text{-ssmc with feedback} + S1\text{--}S3 + \text{Enz}_{\text{partial functions}}$$

*give a correct and complete axiomatization for the classes of deterministic flowgraphs that have the same step-by-step successful computation sequences.*

- **input-output behaviour, nondeterministic case (case  $d\delta$ -strong)**

*The axioms of  $d\delta$ -flow, i.e.*

$$b\delta\text{-flow} = \text{all the axioms in Table (including } \text{Enz}_{\text{relations}})$$

---

<sup>7</sup>This is the core of the algebras that occur in the calculus of flownomials.

<sup>8</sup>This means, if the constant  $\vee_a$  is present, then  $\perp^a = \vee_a \uparrow^a$  should be present, too and similarly for the dual constant  $\wedge$ .

*give a correct and complete axiomatization for the classes of nondeterministic flowgraphs that have the same step-by-step succesful computation sequences.*

All the axiomatisation results above are proved in an abstract setting, namely in the case the connecting components are morphisms in an appropriate abstract theory. Hence we have uniform proofs that may be used, for example, to the case of connections made by simple wiring relations, or by channels with message passing, or by other flownomials. In such an abstract setting the correctness problem consists in the preservation of the algebraic structure when one passes from connections to classes of equivalent flowgraphs. This problem is solved by theorems of the following type. [In cases  $b\delta$  and  $d\delta$  the proofs are done under some mild additional conditions for the connecting theory  $T$ .]

**Theorem 1.3 (Universality Theorem)**

*If  $T$  is an  $xy$ -flow, then  $\mathbb{F}\ell_{xy}[T, X]$  forms the  $xy$ -flow freely generated by adding  $X$  to  $T$ .*

If one replaces “flownomials” by “polynomials” and “ $xy$ -flow” by “ring”, then one gets the classical universal property for polynomials.

## 1.5 Acknowledgements

The calculus of flownomials we are presented here is the result of the attempt I was doing starting from the winter '85/'86 to integrate Elgot's algebraic theory of flowchart schemes and Kleene's calculus for finite automata. I acknowledge with thanks the deep influence the various papers by Elgot and Conway's book on regular Kleene algebra had to the design of the present calculus.

Many people have contributed in an explicit or implicit way to this achievement.

First of all, V.E. Cazanescu had a significant contribution to the development of this calculus and also to its dissemination via the lectures he has given at the Bucharest University.

For keeping me informed with the relevant literature of the field (a vital problem before '89) I am grateful especially to D.B. Benson, S.L. Bloom, B. Courcelle, Z. Esik, J.A. Goguen, J.W. Klop, R. Milner, J.C. Shepherdson and M. Wirsing.

For the opportunity to travel and to present (parts of) this calculus at various meetings, I am indebted especially to J.A. Bergstra, M. Broy, B. Courcelle, Z. Esik, G. Hotz and G. Schmidt.

This book was written in two stages.

A first Romanian version was completed in Bucharest during the fall of 1990 and submitted as a PhD Thesis [Ste91] to the Bucharest University under the supervision of Prof. S. Rudeanu.

The second version you are seeing here was completed during the summer of 1994. For this later opportunity I acknowledge with thanks the financial support of DAAD and the excellent working conditions offered by the Technical University Munich in general and by Prof. Broy's group in special.

*Bucharest*  
*December 1990*

*Munich*  
*July 1994*

*Gheorghe*

*Stefanescu*

**Part I**  
**Acyclic Structures**

# Chapter 2

## Classes of binary relations as enriched symmetric strict monoidal categories

The aim of this chapter is to give axiomatizations for 16 classes of finite relations. These classes may be obtained as intersections of the following classes of finite relations: total relations, surjective relations, univocal relations (= partial functions), and injective relations.

The axiomatizations for the considered classes of relations may be obtained in block. This possibility is based on the existence of a normal form in which all the relations may be represented and which allows to give a syntactical characterization of the considered classes of relations by certain natural, additional conditions (the so called *xy*-restrictions) imposed to the normal form.

The axiomatization is made by equations. More precisely, for each type  $T$  of the sixteen considered types a set of equations  $E_T$  is single out such that the class of relations of type  $T$  forms an initial algebra in the category of algebras that obey the equations  $E_T$ . The algebras which appear in this way are symmetric strict monoidal categories enriched with specific constants and equations.

### 2.1 Short presentation of the results

**a) Preliminaries.** An  $S$ -sorted *signature*  $(S, \Sigma)$  consists in a set  $S$  of sorts and a set  $\Sigma$  of operation symbols together with an arity function  $r : \Sigma \rightarrow S^* \times S$ . A  $\Sigma$ -*algebra*  $A = (\{A_s\}_{s \in S}, \{\sigma_A\}_{\sigma \in \Sigma})$ , or simple  $A = (A_s, \sigma_A)$ , consists in a set  $A_s$  for each  $s \in S$  and a function  $\sigma_A : A_{s_1} \times \dots \times A_{s_{n(\sigma)}} \rightarrow A_s$  for every  $\sigma \in \Sigma$  with  $r(\sigma) = (s_1 \dots s_{n(\sigma)}, s)$ . A  $\Sigma$ -*morphism*  $h : A \rightarrow B$  between two  $\Sigma$ -algebras  $A = (A_s, \sigma_A)$  and  $B = (B_s, \sigma_B)$  is a family of functions  $\{h_s : A_s \rightarrow B_s\}_{s \in S}$  which preserves the operations, that is  $h_s(\sigma_A(a_1, \dots, a_{n(\sigma)})) = \sigma_B(h_{s_1}(a_1), \dots, h_{s_{n(\sigma)}}(a_{n(\sigma)}))$  for every  $\sigma \in \Sigma$  with  $r(\sigma) = (s_1 \dots s_{n(\sigma)}, s)$  and  $a_i \in A_{s_i}$ , for  $i = 1, \dots, n(\sigma)$ .

Let  $T_\Sigma(X)$  be the  $\Sigma$ -algebra freely generated by the  $S$ -sorted set  $X = \{X_s\}_{s \in S}$ , presented as the  $\Sigma$ -algebra of terms built up with variables from  $X$ . A  $\Sigma$ -*equation* is a triple  $(X, L, R)$ , where  $X$  is an  $S$ -sorted set and  $L, R \in T_\Sigma(X)_s$ , for an  $s \in S$ . In the usual notation the equation is  $L = R$ , that is  $L$  is the Left part of the equation,  $R$  is the Right part of the equation and  $X$  is a set of variables of which the equations depends, usually being the

set of the variables which occur in the terms  $L$  and  $R$ . A  $\Sigma$ -algebra *satisfies* the equation  $(X, L, R)$  if  $h_s(L) = h_s(R)$  for every morphism  $h : T_\Sigma(X) \rightarrow A$ , where  $s$  is the (common) sort of  $L$  and  $R$ .

A *presentation*  $(S, \Sigma, E)$  consists in an  $S$ -sorted signature  $(S, \Sigma)$  and a set  $E$  of  $\Sigma$ -equations. We say a type of data  $T$ , as it is encountered in the literature, has an *initial presentation by equations* if a presentation  $(S, \Sigma, E)$  may be given such that  $T$  is a  $\Sigma$ -algebra which satisfies the equations in  $E$  and for every  $\Sigma$ -algebra  $A$  which satisfies the equations in  $E$  there exists a unique  $\Sigma$ -morphism  $h : T \rightarrow A$ .

**b) Sorted binary relations ( $\mathbb{R}el_S$ ).** For every  $a \in S^*$  we denote by  $|a|$  the length of the word  $a$ , and for every  $j \in [|a|]$  we denote by  $a_j \in S$  the  $j$ -th letter of  $a$ . As we use the additive notation “ $\oplus$ ” for concatenation in  $S^*$ , it follows that  $a = a_1 \oplus \dots \oplus a_{|a|}$ .

For  $a, b \in S^*$  define

$$\mathbb{R}el_S(a, b) = \{f : f \subseteq [|a|] \times [|b|] \text{ and } [(i, j) \in f \Rightarrow a_i = b_j]\}.$$

Such an  $f$  is called an *S-sorted relation* from  $a$  to  $b$ .

**c) The signature of  $\mathbb{R}el_S$ .** The basic operations are summation and composition.

- **SUMMATION:** for  $f \in \mathbb{R}el_S(a, b)$  and  $g \in \mathbb{R}el_S(c, d)$  the sum  $f \oplus g \in \mathbb{R}el_S(a \oplus c, b \oplus d)$  is defined by

$$f \oplus g = f \cup \{(|a| + i, |b| + j) : (i, j) \in g\}$$

- **COMPOSITION** is the usual one and is denoted by “ $\cdot$ ”. So that, for  $f \in \mathbb{R}el_S(a, b)$  and  $g \in \mathbb{R}el_S(b, c)$  the composite  $f \cdot g \in \mathbb{R}el_S(a, c)$  is given by

$$f \cdot g = \{(i, j) : \exists k : (i, k) \in f \text{ and } (k, j) \in g\}$$

Beside these operations the signature contains certain constants which are interpreted as the following particular relations:

- **IDENTITY:**

$$1_a = \{(i, i) : i \in [|a|]\} \in \mathbb{R}el_S(a, a);$$

- **BLOCK TRANSPOSITION:**

$${}^a\mathbf{X}^b = \{(i, |b| + i) : i \in [|a|]\} \cup \{(|a| + j, j) : j \in [|b|]\} \in \mathbb{R}el_S(a \oplus b, b \oplus a);$$

- **BLOCK IDENTIFICATION:**

$$\forall_a = \{(i, i) : i \in [|a|]\} \cup \{(|a| + i, i) : i \in [|a|]\} \in \mathbb{R}el_S(a \oplus a, a);$$

- **ADDING DUMMY ELEMENTS TO COSOURCE:**

$$\top_a = \emptyset \in \mathbb{R}el_S(0, a), \text{ where } 0 \text{ is the empty word;}$$

- **ADDING DUMMY ELEMENTS TO SOURCE:**

$$\perp^a = \emptyset \in \mathbb{R}el_S(a, 0);$$

Table 2.1: Axioms for ssmc's (B1–B10) and for constants  
 $\top, \perp, \vee, \wedge$  (without feedback).

B1	$f \oplus (g \oplus h) = (f \oplus g) \oplus h$	B6	$l_a \oplus l_b = l_{a \oplus b}$
B2	$l_0 \oplus f = f = f \oplus l_0$	B7	${}^a\mathbf{X}^b \cdot {}^b\mathbf{X}^a = l_{a \oplus b}$
B3	$f \cdot (g \cdot h) = (f \cdot g) \cdot h$	B8	${}^a\mathbf{X}^0 = l_a$
B4	$l_a \cdot f = f = f \cdot l_b$	B9	${}^a\mathbf{X}^{b \oplus c} = ({}^a\mathbf{X}^b \oplus l_c) \cdot (l_b \oplus {}^a\mathbf{X}^c)$
B5	$(f \oplus f') \cdot (g \oplus g') = f \cdot g \oplus f' \cdot g'$	B10	$(f \oplus g) \cdot {}^c\mathbf{X}^d = {}^a\mathbf{X}^b \cdot (g \oplus f)$ for $f : a \rightarrow c, g : b \rightarrow d$
A	$(\vee_a \oplus l_a) \cdot \vee_a = (l_a \oplus \vee_a) \cdot \vee_a$	A <sup>o</sup>	$\wedge^a \cdot (\wedge^a \oplus l_a) = \wedge^a \cdot (l_a \oplus \wedge^a)$
B	${}^a\mathbf{X}^a \cdot \vee_a = \vee_a$	B <sup>o</sup>	$\wedge^a \cdot {}^a\mathbf{X}^a = \wedge^a$
C	$(\top_a \oplus l_a) \cdot \vee_a = l_a$	C <sup>o</sup>	$\wedge^a \cdot (\perp^a \oplus l_a) = l_a$
D	$\vee_a \cdot \perp^a = \perp^a \oplus \perp^a$	D <sup>o</sup>	$\top_a \cdot \wedge^a = \top_a \oplus \top_a$
E	$\top_a \cdot \perp^a = l_0$		
F	$\vee_a \cdot \wedge^a = (\wedge^a \oplus \wedge^a) \cdot (l_a \oplus {}^a\mathbf{X}^a \oplus l_a) \cdot (\vee_a \oplus \vee_a)$		
G	$\wedge^a \cdot \vee_a = l_a$		
SV1	$\top_0 = l_0$	SV1 <sup>o</sup>	$\perp^0 = l_0$
SV2	$\top_{a \oplus b} = \top_a \oplus \top_b$	SV2 <sup>o</sup>	$\perp^{a \oplus b} = \perp^a \oplus \perp^b$
SV3	$\vee_0 = l_0$	SV3 <sup>o</sup>	$\wedge^0 = l_0$
SV4	$\vee_{a \oplus b} = (l_a \oplus {}^b\mathbf{X}^a \oplus l_b) \cdot (\vee_a \oplus \vee_b)$	SV4 <sup>o</sup>	$\wedge^{a \oplus b} = (\wedge^a \oplus \wedge^b) \cdot (l_a \oplus {}^a\mathbf{X}^b \oplus l_b)$

• BLOCK RAMIFICATION:

$$\wedge^a = \{(i, i) : i \in [|a|]\} \cup \{(i, |a| + i) : i \in [|a|]\} \in \mathbb{R}\text{el}_S(a, a \oplus a).$$

In this way  $\mathbb{R}\text{el}_S$  becomes an algebra having the signature  $(S^* \times S^*, \Sigma)$ , where  $\Sigma$  consists of the binary operations “ $\oplus$ ” and “ $\cdot$ ” and the 0-ary operations (constants)  $l_a, {}^a\mathbf{X}^b, \vee_a, \top_a, \perp^a$ , and  $\wedge^a$ .

**d) A presentation of  $\mathbb{R}\text{el}_S$ .** A presentation of  $\mathbb{R}\text{el}_S$  using the above signature is given in Table 2.1. This shows that  $\mathbb{R}\text{el}_S$  is a symmetric strict monoidal category (axioms B1–B10) enriched with auxiliary constants which satisfy the basic axioms A–G and A<sup>o</sup>–D<sup>o</sup> and the axioms of type SV or SV<sup>o</sup>. These latter axioms show how the vectorial constants may be expressed in terms of scalar ones (“vectorial” means  $\vee_a, \top_a, \perp^a, \wedge^a$  for  $|a| \geq 0$ , while “scalar” is the same, but for  $|a| = 1$ ). Note that the axioms B6 and B8–B9 are of the same type.

Some parentheses are omitted in Table 2.1 using the convention that composition binds stronger than summation.

It is easy to see that the identities in Table 2.1 hold in  $\mathbb{R}\text{el}_S$ .

**e) Particular classes of relations (semantically defined).** From the semantic point of view we are interested in studying the following properties of a relation  $f \in \mathbb{R}\text{el}_S(a, b)$ :

P1)  $f$  is *total*:  $(\forall i \in [|a|])(\exists j \in [|b|]) : (i, j) \in f$ ;



Table 2.2: Restrictions on the indices  $m_j$  and  $n_i$  used in the representations of relations.

(a) all $m_j = 1$	( $\alpha$ ) all $n_i = 1$
(b) all $m_j \leq 1$	( $\beta$ ) all $n_1 \leq 1$
(c) all $m_j \geq 1$	( $\gamma$ ) all $n_i \geq 1$
(d) arbitrary $m_j$	( $\delta$ ) arbitrary $n_i$

P2)  $f$  is *surjective*:  $(\forall j \in [|b|])(\exists i \in [|a|]) : (i, j) \in f$ ;

P3)  $f$  is *univocal* (functional):  $\forall i \in [|a|], j, k \in [|b|] : [(i, j) \in f \text{ and } (i, k) \in f \Rightarrow j = k]$ ;

P4)  $f$  is *injective*:  $\forall k \in [|b|], i, j \in [|a|] : [(i, k) \in f \text{ and } (j, k) \in f \Rightarrow i = j]$ .

These properties are very independent and their combinations give the sixteen types of finite relations for which we shall find initial presentations by equations, see Table 2.3.

**f) A syntactical representation of relations.** For  $a \in S^*$  and  $n \in N$  we inductively define the derived constants  $\vee_a^n \in \mathbb{R}\text{el}_S(na, a)$  and  $\wedge_n^a \in \mathbb{R}\text{el}_S(a, na)$  by

$$\begin{aligned} \vee_a^0 &= \top_a & \wedge_0^a &= \perp^a \\ \vee_a^{n+1} &= (\vee_a^n \oplus \text{l}_a) \cdot \vee_a & \wedge_{n+1}^a &= \wedge^a \cdot (\wedge_n^a \oplus \text{l}_a). \end{aligned}$$

Note that  $\vee_a^1 = \wedge_1^a = \text{l}_a$ ,  $\vee_a^2 = \vee_a$  and  $\wedge_2^a = \wedge^a$ .

In Section 3 we shall prove that every relation  $f \in \mathbb{R}\text{el}_S(a, b)$  may be represented in the following form

$$f = \left( \sum_{j \in [|a|]} \wedge_{m_j}^{a_j} \right) \cdot f_2 \cdot \left( \sum_{i \in [|b|]} \vee_{b_i}^{n_i} \right), \quad (*)$$

where  $f_2$  is a bijection. Moreover,  $f_2$  may be represented in terms of “.”, “ $\oplus$ ”,  $\text{l}_a$  and  ${}^a\mathbf{X}^b$ , for example as a composite of bijections of type  $\text{l}_u \oplus {}^c\mathbf{X}^d \oplus \text{l}_v$ .

**g) Particular classes of relations  $xy\text{-}\mathbb{R}\text{el}_S$  (syntactically defined).** We may define 16 types of finite relations by imposing certain restrictions on the indices  $m_j$  and  $n_i$  used in representation (\*). These restrictions are shown in Table 2.2.

**Notation 2.1** ( $xy\text{-}\mathbb{R}\text{el}_S$ )

Let  $x \in \{a, b, c, d\}$  and  $y \in \{\alpha, \beta, \gamma, \delta\}$  be two restrictions as in Table 2.2. We denote by  $xy\text{-}\mathbb{R}\text{el}_S$  the set of all relations having at least one representation (\*) satisfying restrictions  $x$  and  $y$ .  $\square$

**h) Relating syntax and semantics.** The restrictions  $xy$  give natural classes of relations  $xy\text{-}\mathbb{R}\text{el}_S$  which coincides with the classes of relations defined by the properties P1-P4 defined in **e)**. These classes are presented in Table 2.3. (It is obvious that every  $xy\text{-}\mathbb{R}\text{el}_S$  has the properties corresponding to  $xy$  shown in column 3 of Table 2.3. The opposite implication follows from Theorem 2.8.)

The main results of this chapter correspond to the sixteen lines of Table 2.3. Each line has the following structure. A class of finite relations is defined by the properties in

Table 2.3: Axiomatisation of several classes of relations

Relation	Signature = $\{\oplus, \cdot, I, X\}$ plus	Properties	The class of relations represented by $xy$ -IRels	Presentation = B1-B10 plus	Equivalent notation for $xy$ -IRels
$a\alpha$	-	1,3,2,4	bijective functions	-	$\mathcal{B}is$
$a\beta$	T	1,3,4	injective functions	SV1-SV2	$\mathcal{I}ns$
$a\gamma$	V	1,3,2	surjective functions	A,B,SV3-SV4	$\mathcal{S}urs$
$a\delta$	T, V	1,3	functions	A-C,SV1-SV4	$\mathcal{F}ns$
$b\alpha$	I	3,2,4	converses of injective functions	SV1 <sup>o</sup> -SV2 <sup>o</sup>	$\mathcal{I}ns^{-1}$
$b\beta$	I, T	3,4	partial injective functions	E, SV1-SV2, SV1 <sup>o</sup> -SV2 <sup>o</sup>	$\mathcal{P}Ins$
$b\gamma$	I, V	3,2	partial surjective functions	A,B,D,SV3-SV4, SV1 <sup>o</sup> -SV2 <sup>o</sup>	$\mathcal{P}Surs$
$b\delta$	I, T, V	3	partial functions	A-E,SV1-SV4, SV1 <sup>o</sup> -SV2 <sup>o</sup>	$\mathcal{P}Fns$
$a\alpha$	$\wedge$	1,2,4	converses of surjective functions	A <sup>o</sup> ,B <sup>o</sup> ,SV3 <sup>o</sup> -SV4 <sup>o</sup>	$\mathcal{S}urs^{-1}$
$a\beta$	$\wedge, T$	1,4	converses of partial surjective functions	A <sup>o</sup> ,B <sup>o</sup> ,D <sup>o</sup> , SV1-SV2,SV3 <sup>o</sup> -SV4 <sup>o</sup>	$\mathcal{P}Surs^{-1}$
$a\gamma$	$\wedge, V$	1,2	surjective and total relations	A,B,F,G, A <sup>o</sup> ,B <sup>o</sup> , SV3-SV4,SV3 <sup>o</sup> -SV4 <sup>o</sup>	$\mathcal{S}TRels$
$a\delta$	$\wedge, T, V$	1	total relations	A-C,F,G, A <sup>o</sup> ,B <sup>o</sup> ,D <sup>o</sup> , SV1-SV4,SV3 <sup>o</sup> -SV4 <sup>o</sup>	$\mathcal{T}TRels$
$a\alpha$	I, $\wedge$	2,4	converses of functions	A <sup>o</sup> -C <sup>o</sup> ,SV1 <sup>o</sup> -SV4 <sup>o</sup>	$\mathcal{F}ns^{-1}$
$a\beta$	I, $\wedge, T$	4	injective relations	E, A <sup>o</sup> -D <sup>o</sup> , SV1-SV2,SV1 <sup>o</sup> -SV4 <sup>o</sup>	$\mathcal{P}Fns^{-1}$
$a\gamma$	I, $\wedge, V$	2	surjective relations	A,B,D,F,G, A <sup>o</sup> -C <sup>o</sup> , SV3-SV4,SV1 <sup>o</sup> -SV4 <sup>o</sup>	$\mathcal{S}Rels$
$a\delta$	I, $\wedge, T, V$	-	relations	A-G, A <sup>o</sup> -D <sup>o</sup> , SV1-SV4,SV1 <sup>o</sup> -SV4 <sup>o</sup>	$\mathcal{I}Rels$

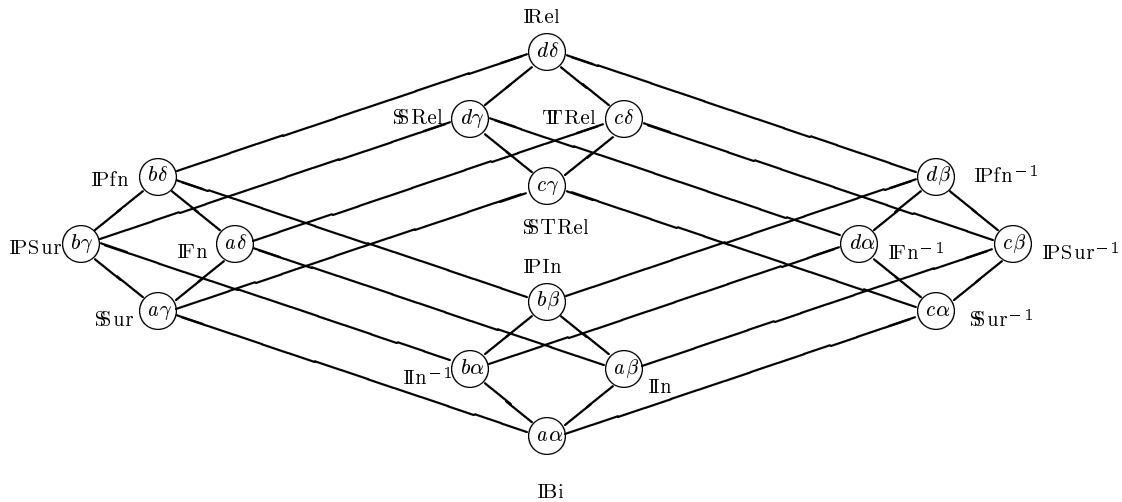

Figure 2.1: Relations

column 3, is denoted as it is shown in column 6, and its elements are known by the name indicated in column 4. The class is (syntactically) characterized by the fact that its elements have at least one representation (\*) satisfying the restrictions indicated in column 1. An equivalent (semantical) characterization is the property that the class is an initial algebra in the variety of algebras defined by the signature in column 2 and the equations in column 5 (see Corollary 2.25).

The class of relations under consideration may be ordered using the relation of inclusion. The resulting ordered set is presented by the Hasse diagram in Figure 2.1.

**i) The results.** In order to get a presentation for one class of finite relations considered above one chooses those equations in Table 2.3 using the operations in the signature associated with the considered type of relations only. The resulted sets of equations are given in column 5 for each particular case. Corollary 2.25 contains the following result.

**Theorem 2.2** *Each of the sixteen classes of finite relations may be presented as an initial algebra in the variety of algebras defined by the signature in column 2 and satisfying the equations in column 5 of Table 2.3.  $\square$*

**j) Extensions.** The above axiomatisation is useful for the study of the acyclic flowgraphs. In order to apply it to the study of the cyclic flowgraphs one has to extend the axiomatisation by adding a looping operation. In Theorem 6.4 of this paper we give the axiomatisations obtained by adding the feedback as the cyclic operation.

## 2.2 Bijections ( $a\alpha\text{-Rel}_S$ ) and symmetric strict monoidal categories (ssmc's)

**Definition 2.3** We say  $B$  is a *strict monoidal category* (shortly, *smc*) if:

- $B$  is a category  $(B, \cdot, l_a)$ ;
- the class of the objects of  $B$  forms a monoid  $(\mathcal{O}(B), \oplus, 0)$ ;
- an operation of summation on morphisms is given (also denoted by “ $\oplus$ ”):

$$\oplus : B(a, b) \times B(c, d) \rightarrow B(a \oplus c, b \oplus d)$$

and the axioms B1–B2 and B5–B6 in Table 2.1 hold.<sup>1</sup>

A *symmetric strict monoidal category* (shortly, *ssmc*) is a smc enriched with

- constants  $X$ : for  $a, b$  objects in  $B$

$${}^a X^b \in B(a \oplus b, b \oplus a)$$

and such that the axioms B7–B10 in Table 2.1 hold.

A *morphism between two smc's* (resp. *ssmc's*)  $H : B \rightarrow B'$  is a functor whose restriction on objects is a monoid morphism and which commutes with summation (resp. with summation and constants  ${}^a X^b$ ).<sup>2</sup>  $\square$

Using the sematical definition (i.e., column 4 in Table 2.3) it is easy to see that each of the 16 classes  $xy\text{-Rel}_S$  is a csms. Using B7 it follows that the following identities hold in a ssmc:

$$\text{B8}' \quad {}^0 X^a = l_a$$

$$\text{B9}' \quad {}^{a \oplus b} X^c = (l_a \oplus {}^b X^c) \cdot ({}^a X^c \oplus l_b)$$

**Lemma 2.4** *The following identities hold in a ssmc:*

$$(1) \quad {}^a X^{b \oplus c \oplus d} \cdot (l_b \oplus {}^c X^d \oplus l_a) = (l_{a \oplus b} \oplus {}^c X^d) \cdot ({}^a X^{b \oplus d} \oplus l_c) \cdot (l_{b \oplus d} \oplus {}^a X^c)$$

$$(2) \quad ({}^{a \oplus b} X^c \oplus l_d) \cdot (l_{c \oplus a} \oplus {}^b X^d) = (l_{a \oplus b} \oplus {}^c X^d) \cdot (l_a \oplus {}^b X^d \oplus l_c) \cdot {}^{a \oplus d \oplus b} X^c$$

**Proof:** (1) Using B10 and then B9 we get

$$\begin{aligned} {}^a X^{b \oplus c \oplus d} \cdot (l_b \oplus {}^c X^d \oplus l_a) &= (l_a \oplus l_b \oplus {}^c X^d) \cdot {}^a X^{b \oplus d \oplus c} \\ &= (l_{a \oplus b} \oplus {}^c X^d) ({}^a X^{b \oplus d} \oplus l_c) (l_{b \oplus d} \oplus {}^a X^c) \end{aligned}$$

---

<sup>1</sup>Hence a ssmc is defined by B1–B6.

<sup>2</sup>E.g.,  $H : B \rightarrow B'$  is a morphism of ssms's if it is given by a morphism of monoids  $h : \mathcal{O}(B) \rightarrow \mathcal{O}(B')$  and a family of applications  $H : B(a, b) \rightarrow B'(h(a), h(b))$  obeying the commutation rules:  $H(f \cdot g) = H(f) \cdot H(g)$ ;  $H(f \oplus g) = H(f) \oplus H(g)$ ;  $H(l_a) = l_{h(a)}$ ;  $H({}^a X^b) = {}^{h(a)} X^{h(b)}$ .

(2) Using in turn, B7, B9' and B10 we get

$$\begin{aligned}
({}^{a\oplus b}\mathbf{X}^c \oplus l_d) (l_{c\oplus a} \oplus {}^b\mathbf{X}^d) &= (l_{a\oplus b} \oplus {}^c\mathbf{X}^d) (l_{a\oplus b} \oplus {}^d\mathbf{X}^c) ({}^{a\oplus b}\mathbf{X}^c \oplus l_d) (l_{c\oplus a} \oplus {}^b\mathbf{X}^d) \\
&= (l_{a\oplus b} \oplus {}^c\mathbf{X}^d) \cdot {}^{a\oplus b\oplus d}\mathbf{X}^c \cdot (l_{c\oplus a} \oplus {}^b\mathbf{X}^d) \\
&= (l_{a\oplus b} \oplus {}^c\mathbf{X}^d) (l_a \oplus {}^b\mathbf{X}^d \oplus l_c) \cdot {}^{a\oplus d\oplus b}\mathbf{X}^c
\end{aligned}$$

□

**Theorem 2.5** For every ssmc  $(B, \oplus, \cdot, l_a, {}^a\mathbf{X}^b)$  and for every morphism of monoids  $h : S^* \rightarrow \mathcal{O}(B)$  there exists a unique morphism of ssmc's  $H : \mathbb{B}i_S \rightarrow B$  whose restriction to the objects coincides with  $h$ .

**Proof:** Since on objects  $H$  coincides with  $h$ , the only problem is the definition of  $H$  on morphisms.

We prove by induction on  $n$  that there is a function  $H$  which maps an  $g \in \mathbb{B}i_S(c, b)$  with  $|c| \leq n$  in  $H(g) \in B(h(c), h(b))$  such that

- 1)  $H(l_a) = l_{h(a)}$  if  $|a| \leq n$
- 2)  $H({}^a\mathbf{X}^b) = {}^{h(a)}\mathbf{X}^{h(b)}$  if  $|a \oplus b| \leq n$
- 3)  $H(f \cdot g) = H(f) \cdot H(g)$  if  $f \in \mathbb{B}i_S(a, b)$ ,  $g \in \mathbb{B}i_S(b, c)$  and  $|a| \leq n$
- 4)  $H(f \oplus g) = H(f) \oplus H(g)$  if  $f \in \mathbb{B}i_S(a, b)$ ,  $g \in \mathbb{B}i_S(c, d)$  and  $|a \oplus c| \leq n$

For  $n = 1$  we define  $H(l_0) = l_0$  and  $H(l_s) = l_{h(s)}$ , for  $s \in S$ . It is obvious that the above properties 1–4 hold.

Suppose we have defined  $H$  for all  $g \in \mathbb{B}i_S(c, b)$  with  $|c| < n$  and obeying properties 1–4. Now, we define  $H$  for bijections of length  $n$  as follows:

Let  $f \in \mathbb{B}i_S(a, b)$  with  $|a| = n$ . For an  $i \in [|a|]$  denote  $a = a' \oplus a_i \oplus a''$  with  $|a'| = i - 1$  and similarly  $b = b' \oplus b_{f(i)} \oplus b''$  with  $|b'| = f(i) - 1$ . Then there exists a unique  $f_i \in \mathbb{B}i_S(a' \oplus a'', b' \oplus b'')$  such that

$$f = (l_{a'} \oplus {}^{a_i}\mathbf{X}^{a''}) (f_i \oplus l_{a_i}) (l_{b'} \oplus {}^{b''}\mathbf{X}^{b_{f(i)}})$$

So that it is natural to define  $H(f)$  as  $E_i$ , where

$$E_i = (l_{h(a')} \oplus {}^{h(a_i)}\mathbf{X}^{h(a'')}) (H(f_i) \oplus l_{h(a_i)}) (l_{h(b')} \oplus {}^{h(b'')}\mathbf{X}^{h(b_{f(i)})})$$

The problem now is to show the definition is correct, i.e. the morphism  $E_i$  does not depend on  $i$ . For this, suppose  $i, j \in [|a|]$  are two different indices, say  $i < j$ . Let  $a = a' \oplus a_i \oplus a'' \oplus a_j \oplus a'''$  with  $|a'| = i - 1$  and  $|a' \oplus a_i \oplus a''| = j - 1$ . There are two cases:

- $f(i) < f(j)$
- $f(i) > f(j)$

Since there is small difference between them, we prove the correctness of the definition only for the second case.

As  $f(i) > f(j)$  we may write  $b = b' \oplus a_j \oplus b'' \oplus a_i \oplus b'''$  with  $|b'| = f(j) - 1$  and  $|b' \oplus a_j \oplus b''| = f(i) - 1$ . It is clear that it is a unique  $g \in \mathbb{B}i_S(a' \oplus a'' \oplus a''', b' \oplus b'' \oplus b''')$  such that

$$f_i = (l_{a' \oplus a''} \oplus {}^{a_j}\mathbf{X}^{a'''}) (g \oplus l_{a_j}) (l_{b'} \oplus {}^{b'' \oplus b'''}\mathbf{X}^{a_i})$$

$$f_j = (l_{a'} \oplus a_i \mathbf{X}^{a'' \oplus a'''}) (g \oplus l_{a_i}) (l_{b' \oplus b''} \oplus b''' \mathbf{X}^{a_i})$$

Using the inductive hypothesis we get

$$H(f_i) = (l_{h(a' \oplus a'')} \oplus h(a_j) \mathbf{X}^{h(a''')}) (H(g) \oplus l_{h(a_j)}) (l_{h(b')} \oplus h(b'' \oplus b''') \mathbf{X}^{h(a_j)})$$

and similarly for  $H(f_j)$ . By substituting this in  $E_i$  we get

$$(1) \ E_i = (l_{h(a')} \oplus h(a_i) \mathbf{X}^{h(a'' \oplus a_j \oplus a''')}) (l_{h(a' \oplus a'')} \oplus h(a_j) \mathbf{X}^{h(a''')}) \oplus l_{h(a_i)} \\ \cdot (H(g) \oplus l_{h(a_j \oplus a_i)}) (l_{h(b')} \oplus h(b'' \oplus b''') \mathbf{X}^{h(a_j)} \oplus l_{h(a_j)}) (l_{h(b' \oplus a_j \oplus b'')} \oplus h(b''') \mathbf{X}^{h(a_i)})$$

and similarly

$$E_j = (l_{h(a' \oplus a_i \oplus a'')} \oplus h(a_j) \mathbf{X}^{h(a''')}) (l_{h(a')} \oplus h(a_i) \mathbf{X}^{h(a'' \oplus a''')}) \oplus l_{h(a_j)} \\ \cdot (H(g) \oplus l_{h(a_i \oplus a_j)}) (l_{h(b' \oplus b'')} \oplus h(b''') \mathbf{X}^{h(a_i)} \oplus l_{h(a_j)}) (l_{h(b')} \oplus h(b'' \oplus a_i \oplus b''') \mathbf{X}^{h(a_j)})$$

By axiom B7,

$$l_{h(a_i \oplus a_j)} = h(a_i) \mathbf{X}^{h(a_j)} \cdot l_{h(a_j \oplus a_i)} \cdot h(a_j) \mathbf{X}^{h(a_i)}$$

and using B6 we get

$$(2) \ E_j = (l_{h(a' \oplus a_i \oplus a'')} \oplus h(a_j) \mathbf{X}^{h(a''')}) (l_{h(a')} \oplus h(a_i) \mathbf{X}^{h(a'' \oplus a''')}) \oplus l_{h(a_j)} \\ \cdot (l_{h(a' \oplus a'' \oplus a''')} \oplus h(a_i) \mathbf{X}^{h(a_j)}) (H(g) \oplus l_{h(a_j \oplus a_i)}) (l_{h(b' \oplus b'' \oplus b''')} \oplus h(a_j) \mathbf{X}^{h(a_i)}) \\ \cdot (l_{h(b' \oplus b'')} \oplus h(b''') \mathbf{X}^{h(a_i)} \oplus l_{h(a_j)}) (l_{h(b')} \oplus h(b'' \oplus a_i \oplus b''') \mathbf{X}^{h(a_j)})$$

Using Lemma 2.4 and axiom B6 we find that the product of the first two factors in (1) is equal to the product of the first three factors in (2) and the product of the last two factors in (1) is equal to the product of the last three factors in (2), hence

$$E_i = E_j$$

Consequently, we may correctly define  $H(f)$  by

$$H(f) = (l_{h(a_1 \oplus \dots \oplus a_{i-1})} \oplus h(a_i) \mathbf{X}^{h(a_{i+1} \oplus \dots \oplus a_n)}) (H(f_i) \oplus l_{h(a_i)}) \\ \cdot (l_{h(b_1 \oplus \dots \oplus b_{f(i)-1})} \oplus h(b_{f(i)+1} \oplus \dots \oplus b_n) \mathbf{X}^{h(a_i)})$$

Finally, let us check that with this definition  $H$  fulfills conditions 1–4. Condition 1 obviously holds. For 2, in the nontrivial case  $a \neq 0$ , say  $a = c \oplus s$  with  $s \in S$ , we see that

$$H(a \mathbf{X}^b) = (l_{h(c)} \oplus h(s) \mathbf{X}^{h(b)}) (H(c \mathbf{X}^b) \oplus l_{h(s)}) (l_{h(b \oplus c)} \oplus h(0) \mathbf{X}^{h(s)}) \\ = (l_{h(c)} \oplus h(s) \mathbf{X}^{h(b)}) (h(c) \mathbf{X}^{h(b)} \oplus l_{h(s)}) \\ = h(c) \oplus h(s) \mathbf{X}^{h(b)} \\ = h(a) \mathbf{X}^{h(b)}$$

For 3, assume  $f \in \mathbb{B}i_S(a, b)$ ,  $g \in \mathbb{B}i_S(b, c)$  with  $|a| = n$ . Take an  $i \in [|a|]$  and write  $a = a' \oplus a_i \oplus a''$  with  $|a'| = i - 1$ ,  $b = b' \oplus a_i \oplus b''$  with  $|b'| = f(i) - 1$  and  $c = c' \oplus a_i \oplus c''$  with  $|c'| = g(f(i)) - 1$ . If we denote by  $g_i$  the bijections associated to  $g$  in the same way the bijections  $f_i$  were associated to  $f$ , then we get

$$f \cdot g = (l_{a'} \oplus a_i \mathbf{X}^{a''}) (f_i \cdot g_{f(i)} \oplus l_{a_i}) (l_{c'} \oplus c'' \mathbf{X}^{a_i})$$

Hence

$$\begin{aligned}
H(f) \cdot H(g) &= (l_{h(a')} \oplus {}^{h(a_i)}\mathbf{X}^{h(a'')}) (H(f_i) \oplus l_{h(a_i)}) (l_{h(b')} \oplus {}^{h(b'')}\mathbf{X}^{h(a_i)}) \\
&\quad \cdot (l_{h(b')} \oplus {}^{h(a_i)}\mathbf{X}^{h(b'')}) (H(g_{f(i)}) \oplus l_{h(a_i)}) (l_{h(c')} \oplus {}^{h(c'')}\mathbf{X}^{h(a_i)}) \\
&= (l_{h(a')} \oplus {}^{h(a_i)}\mathbf{X}^{h(a'')}) (H(f_i \cdot g_{f(i)}) \oplus l_{h(a_i)}) (l_{h(c')} \oplus {}^{h(c'')}\mathbf{X}^{h(a_i)}) \\
&= H(f \cdot g)
\end{aligned}$$

The verification of condition 4 is easy.

Consequently we have defined by induction a morphism of ssmc's  $H : \mathbb{B}i_S \rightarrow B$ . It is obvious that this is the unique ssmc-morphism whose restriction to objects coincides with  $h$ .  $\square$

**Corollary 2.6**  $\mathbb{B}i_S$  is an initial object in the category  $\mathbf{SSMC}_S$  of those ssmc's which have  $S^*$  as the monoid of objects and whose morphisms are all the morphisms of ssmc's which preserve the objects.  $\square$

From these results we get the following *computation rule*:

If two expressions built up with “.”, “ $\oplus$ ”,  $l_a, {}^a\mathbf{X}^b$  ( $a, b \in S^*$ ) specify the same  $S$ -sorted bijection when they are interpreted in  $\mathbb{B}i_S$ , then they specify the same element when they are interpreted in an arbitrary ssmc.

For example, it is easy to see that for an expression  $g$  from  $a \oplus b \oplus c$  to  $a' \oplus b' \oplus c'$ , built up with the specifies constants and operations, the expressions

$$E = (l_a \oplus {}^x\mathbf{X}^{b \oplus y \oplus c}) (l_{a \oplus b} \oplus {}^y\mathbf{X}^c \oplus l_x) (g \oplus l_{y \oplus x}) (l_{a'} \oplus {}^{b' \oplus c'}\mathbf{X}^y \oplus l_x) (l_{a' \oplus y \oplus b'} \oplus {}^{c'}\mathbf{X}^x)$$

and

$$\begin{aligned}
E' &= (l_{a \oplus x \oplus b} \oplus {}^y\mathbf{X}^c) (l_a \oplus {}^x\mathbf{X}^{b \oplus c} \oplus l_y) (l_{a \oplus b \oplus c} \oplus {}^x\mathbf{X}^y) \\
&\quad \cdot (g \oplus l_{y \oplus x}) (l_{a' \oplus b' \oplus c'} \oplus {}^y\mathbf{X}^x) (l_{a' \oplus b'} \oplus {}^{c'}\mathbf{X}^x \oplus l_y) (l_{a'} \oplus {}^{b' \oplus x \oplus c'}\mathbf{X}^y)
\end{aligned}$$

represent the same bijection when they are interpreted in the ssmc

$$\mathbb{B}i_{\{a, b, c, a', b', c', x, y\}}(a \oplus x \oplus b \oplus y \oplus c, a' \oplus y \oplus b' \oplus x \oplus c')$$

(see Figure 2.2). Hence  $E$  and  $E'$  represent the same morphism when they are interpreted in an arbitrary ssmc.<sup>3</sup>

Another consequence of Theorem 2.5 is the possibility to denote shortly the ground terms in a ssmc. Suppose we have a usual bijection  $\varphi[n] \rightarrow [n]$  and  $n$ , —not necessarily different— objects  $a_1, \dots, a_n$  in a ssmc  $B$ . We denote by

$$(\varphi(1)_{a_1} \varphi(2)_{a_2} \dots \varphi(n)_{a_n}) \in B(a_1 \oplus \dots \oplus a_n, a_{\varphi^{-1}(1)} \oplus \dots \oplus a_{\varphi^{-1}(n)})$$

the morphism of  $B$  (sometimes called *abstract bijection*) obtained in the following way. Take  $n$  distinct symbols  $x_1, \dots, x_n$  and let

$$\overline{\varphi} \in \mathbb{B}i_{\{x_1, \dots, x_n\}}(x_1 \oplus \dots \oplus x_n, x_{\varphi^{-1}(1)} \oplus \dots \oplus x_{\varphi^{-1}(n)})$$

---

<sup>3</sup>A formal proof of this statement is given in Lemma 2.4.

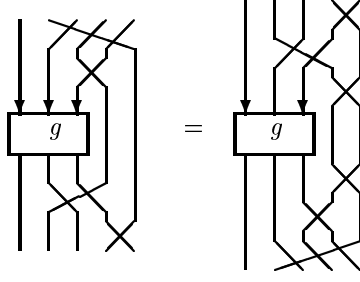

Figure 2.2: Example

be the multisorted bijection which coincides with  $\varphi$ , i.e.  $\overline{\varphi}(i) = \varphi(i)$ ,  $\forall i \in [n]$ . Cf. Theorem 2.5, there exists a morphism of ssmc's  $H$  which extends the monoid morphism  $h : \{x_1, \dots, x_n\}^* \rightarrow \mathcal{O}(B)$ , where  $h$  is defined by mapping  $x_i$  to  $a_i$ , for  $i \in [n]$ . Then we define

$$(\varphi(1)_{a_1} \varphi(2)_{a_2} \dots \varphi(n)_{a_n}) = H(\overline{\varphi}).$$

With this notation the morphisms  $E$  and  $E'$  above may be simply written as

$$E = E' = (1_a 5_x 2_b 4_y 3_c) (g \oplus \mathbb{1}_{y \oplus x}) (1_{a'} 3_{b'} 5_{c'} 2_y 4_x).$$

**Proposition 2.7** *Suppose we are given a usual bijection  $\varphi : [n] \rightarrow [n]$ , a ssmc  $B$  and  $n$  morphisms  $f_i \in B(a_i, b_i)$ ,  $\forall i \in [n]$ . Then,*

$$(f_1 \oplus \dots \oplus f_n) \cdot (\varphi(1)_{b_1} \dots \varphi(n)_{b_n}) = (\varphi(1)_{a_1} \dots \varphi(n)_{a_n}) \cdot (f_{\varphi^{-1}(1)} \oplus \dots \oplus f_{\varphi^{-1}(n)})$$

**Proof:** Since every bijection  $\phi$  is a product of transpositions of the type  $\mathbb{1}_r \oplus \mathbb{1} \mathbf{X}^1 \oplus \mathbb{1}_{n-r-2}$ , it is enough to prove the proposition for such bijections. In such a particular case the identity may be written as

$$\begin{aligned} & (f_1 \oplus \dots \oplus f_r \oplus f_{r+1} \oplus f_{r+2} \oplus f_{r+3} \oplus \dots \oplus f_n) \cdot (\mathbb{1}_{b_1 \oplus \dots \oplus b_r} \oplus \mathbb{1} \mathbf{X}^{b_{r+2}} \oplus \mathbb{1}_{b_{r+3} \oplus \dots \oplus b_n}) \\ &= (\mathbb{1}_{a_1 \oplus \dots \oplus a_r} \oplus \mathbb{1} \mathbf{X}^{a_{r+2}} \oplus \mathbb{1}_{a_{r+3} \oplus \dots \oplus a_n}) \cdot (f_1 \oplus \dots \oplus f_r \oplus f_{r+2} \oplus f_{r+1} \oplus f_{r+3} \oplus \dots \oplus f_n) \end{aligned}$$

and obviously holds in  $B$  due to axiom B10.  $\square$

We finish this section with some computation rules for the above representations of the abstract bijections.

- $\mathbb{1}_a = (1_a)$
- $(\sigma(1)_{a_1} \dots \sigma(m)_{a_m}) \oplus (\tau(1)_{b_1} \dots \tau(n)_{b_n})$   
 $= (\sigma(1)_{a_1} \dots \sigma(m)_{a_m} (\tau(1) + m)_{b_1} \dots (\tau(n) + m)_{b_n})$
- If  $a_i = b_{\sigma(i)}$ ,  $\forall i \in [n]$ , then  
 $(\sigma(1)_{a_1} \dots \sigma(n)_{a_n}) \cdot (\tau(1)_{b_1} \dots \tau(n)_{b_n}) = (\tau(\sigma(1))_{a_1} \dots \tau(\sigma(n))_{a_n})$



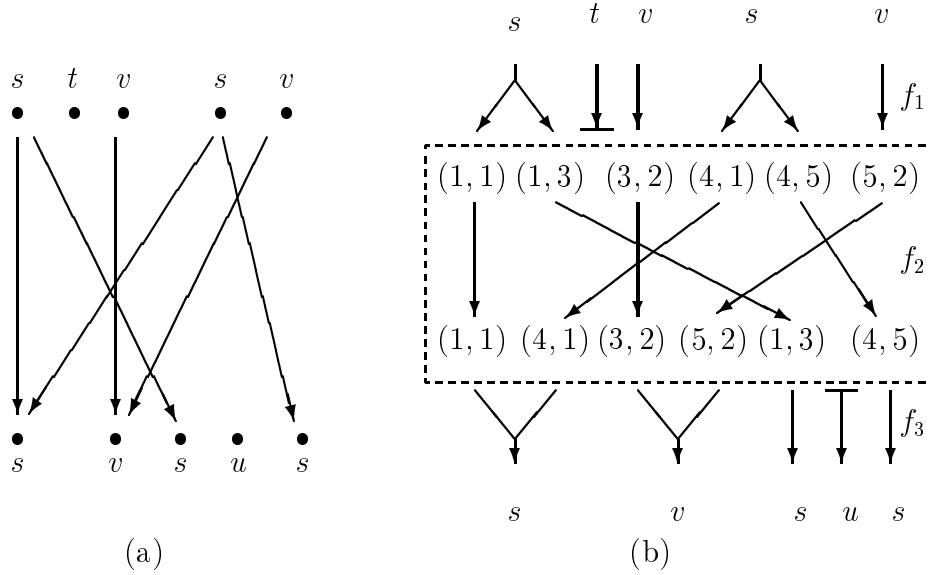

Figure 2.3: An arbitrary relation (a) and its normal form (b).

- $(\sigma(1)_{a_1} \dots \sigma(i)_{a'_i \oplus a''_i} \dots \sigma(n)_{a_n}) = (\tau(1)_{a_1} \dots \tau(i)_{a'_i} \tau(i+1)_{a''_i} \dots \tau(n+1)_{a_n})$ ,  
where for  $j \in [n+1]$

$$\tau(j) = \begin{cases} \sigma(j) & \text{when } 1 \leq j \leq i \quad \text{and } \sigma(j) \leq \sigma(i) \\ \sigma(j) + 1 & \text{when } 1 \leq j \leq i \quad \text{and } \sigma(j) > \sigma(i) \\ \sigma(j-1) & \text{when } i < j \leq n+1 \quad \text{and } \sigma(j-1) < \sigma(i) \\ \sigma(j-1) + 1 & \text{when } i < j \leq n+1 \quad \text{and } \sigma(j-1) \geq \sigma(i) \end{cases}$$

- $(\sigma(1)_{a_1} \dots \sigma(i)_0 \dots \sigma(n)_{a_n}) = (\tau(1)_{a_1} \dots \tau(i-1)_{a_{i-1}} \tau(i)_{a_{i+1}} \dots \tau(n-1)_{a_n})$ ,  
where for  $j \in [n-1]$

$$\tau(j) = \begin{cases} \sigma(j) & \text{when } 1 \leq j < i \quad \text{and } \sigma(j) < \sigma(i) \\ \sigma(j) - 1 & \text{when } 1 \leq j < i \quad \text{and } \sigma(j) > \sigma(i) \\ \sigma(j+1) & \text{when } i \leq j \leq n-1 \quad \text{and } \sigma(j+1) < \sigma(i) \\ \sigma(j+1) - 1 & \text{when } i \leq j \leq n-1 \quad \text{and } \sigma(j+1) > \sigma(i) \end{cases}$$

## 2.3 Normal form of relations

We start with an example. Suppose that  $S \supset \{s, t, u, v\}$  and let us consider the relation

$$f = \{(1, 3), (1, 1), (4, 1), (4, 5), (3, 2), (5, 2)\} \in \mathbb{R}\text{el}_S(a, b)$$

where  $a = s \oplus t \oplus v \oplus s \oplus v$  and  $b = s \oplus v \oplus s \oplus u \oplus s$ , see Figure 2.3.(a).

A relation  $f$  may be represented as it is shown in Figure 2.3.(b) using the following method:

First, to every arrow  $(j, i) \in f$  we attach a sort, namely  $a_j$  (which is equal with  $b_i$ ).

Then we order all the pairs  $(j, i)$  in  $f$  by using the lexicographical order

$$(3.1) \quad (j, i) \prec (j', i') \iff j < j' \text{ or } (j = j' \text{ and } i < i')$$

and we obtain the upper side of the rectangle  $f_2$ .

Next, in a similar way we order the pairs  $(j, i)$  in  $f$  by using the antilexicographical order

$$(3.2) \quad (j, i) \prec^a (j', i') \iff i < i' \text{ or } (i = i' \text{ and } j < j')$$

in order to obtain the lower side of rectangle  $f_2$ .

Finally:

- the arrows of the bijection  $f_2$  are obtain by connecting the pairs  $(j, i)$  of the upper side to the pair  $(j, i)$  of the lower side
- the function  $f_3$  corresponds to the projection on the second component  $q(j, i) = i$  and
- the relation  $f_1$  is the oposite of the projection on the first component  $p(j, i) = j$ .

Consequently, we get a decomposition of  $f$  as

$$\begin{aligned} & f_1 \cdot f_2 \cdot f_3, \text{ where} \\ & f_1 = \Lambda_2^s \oplus \Lambda_0^t \oplus \Lambda_1^v \oplus \Lambda_2^s \oplus \Lambda_1^v, \\ & f_2 \text{ is a bijection and} \\ & f_3 = \mathbb{V}_s^2 \oplus \mathbb{V}_v^2 \oplus \mathbb{V}_s^1 \oplus \mathbb{V}_u^0 \oplus \mathbb{V}_s^1. \end{aligned}$$

A representation of a relation  $f$  in the form  $f_1 \cdot f_2 \cdot f_3$ , with  $f_1, f_2$  and  $f_3$  as above, is not unique mainly by two reasons:

- the pairs in  $f$  may be arranged in another linear order, hence the bijection  $f_2$  is not unique;
- more than one path may connect an input  $j$  with an output  $i$ .

However, we may get a unique normal form representation by putting additional restrictions to the representation as in the next theorem.

**Theorem 2.8** *Every  $f \in \mathbb{R}\text{el}_S(a, b)$  may be written in a unique way as  $f_1 \cdot f_2 \cdot f_3$ , where*

$$(i) \quad f_1 = \Lambda_{m_1}^{a_1} \oplus \dots \oplus \Lambda_{m_{|a|}}^{a_{|a|}} \text{ with } m_j \geq 0, \forall j \in [|a|],$$

$f_2$  from  $\mathbb{B}i_S$  and

$$f_3 = \mathbb{V}_{b_1}^{n_1} \oplus \dots \oplus \mathbb{V}_{b_{|b|}}^{n_{|b|}} \text{ with } n_i \geq 0, \forall i \in [|b|];$$

(ii) for every  $(j, i) \in f$  there exists a unique pair  $(k, k') \in f_2$  such that  $(j, k) \in f_1$  and  $(k', i) \in f_3$ ;

(iii) for every  $j \in [|a|]$  the restriction of  $f_2$  on the set  $|m_1 a_1 \oplus \dots \oplus m_{j-1} a_{j-1}| + [|m_j a_j|]$  is an increasing function and for every  $i \in [|b|]$  the corestriction of  $f_2$  to the set  $|n_1 b_1 \oplus \dots \oplus n_{i-1} b_{i-1}| + [|n_i b_i|]$  is an increasing partial function.

**Proof:** Let  $f \in \mathbb{R}\text{el}_S(a, b)$ . Denote

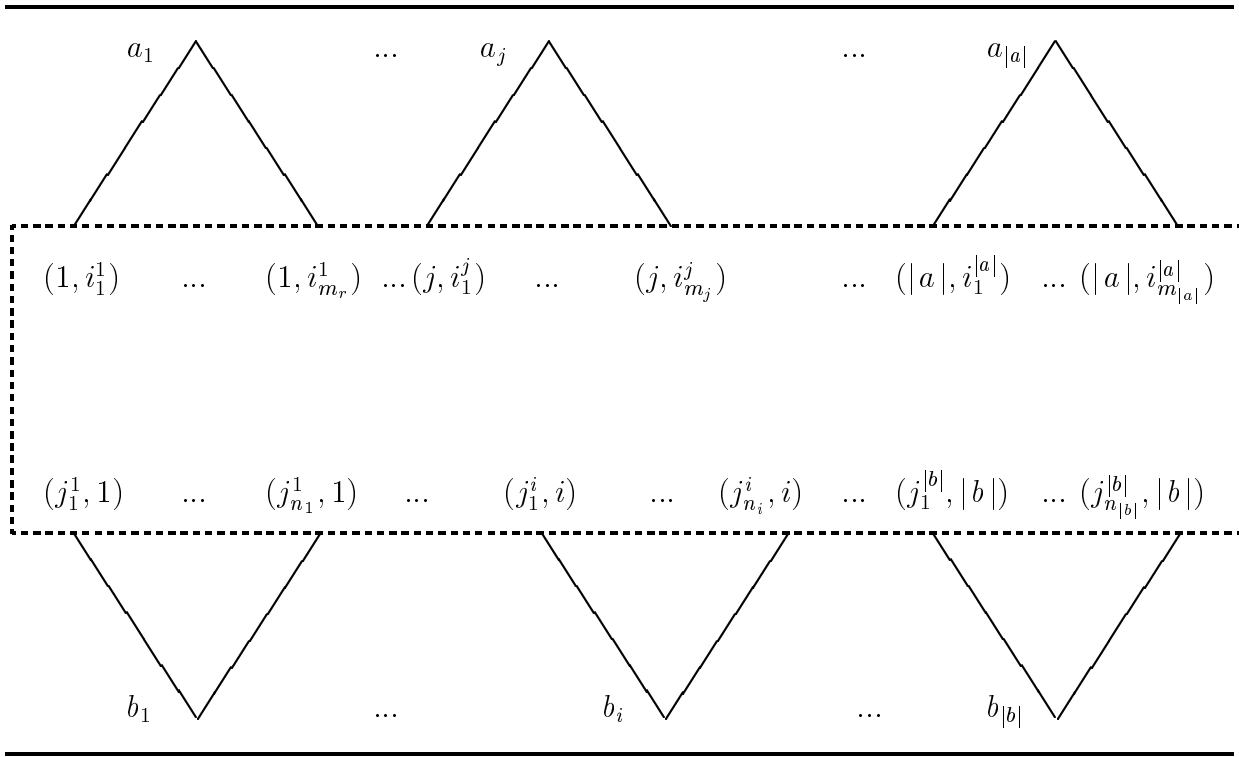

Figure 2.4: Standard representation

$$m_j := \text{card}\{i \in [|b|] : (j, i) \in f\}, \text{ for } j \in [|a|] \text{ and}$$

$$n_i := \text{card}\{j \in [|a|] : (j, i) \in f\}, \text{ for } i \in [|b|].$$

By using the lexicographical order (3.1) we may write the pairs of the relation  $f$  as in the upper side of the rectangle in Figure 2.4, where  $1 \leq i_1^j < i_2^j < \dots < i_{m_j}^j \leq |b|$ ,  $\forall j \in [|a|]$ . Similarly, using the antilexicographical order (3.2) we write the pairs of  $f$  as in the lower side of the rectangle in Figure 2.4, where  $1 \leq j_1^i < j_2^i < \dots < j_{n_i}^i \leq |a|$ ,  $\forall i \in [|b|]$ .

Define  $f_1$  and  $f_3$  by the equalities in (i); these relations are described in the upper and the lower part of Figure 2.4, respectively. In order to define bijection  $f_2$ , for each  $(i, j) \in f$  we draw an arrow inside the rectangle from the pair  $(j, i)$  of the upper side to the pair  $(j, i)$  of the lower side. Formally, for every  $j \in [|a|]$ ,  $u \in [m_j]$ ,  $i \in [|b|]$  and  $v \in [n_i]$

$$f_2(m_1 + \dots + m_{j-1} + u) = n_1 + \dots + n_{i-1} + v$$

iff

$$(j, i) \in f, \quad u = \text{card}\{(j, r) \in f : r \leq i\} \text{ and } v = \text{card}\{(r, i) \in f : r \leq j\}$$

First we check (i). For  $(j, i) \in f$ , if  $u$  and  $v$  are defined as above, then using the observation that  $(j, m_1 + \dots + m_{j-1} + u) \in f_1$  and  $(n_1 + \dots + n_{i-1} + v, i) \in f_3$ , it follows that  $(j, i) \in f_1 \cdot f_2 \cdot f_3$ , hence  $f \subseteq f_1 \cdot f_2 \cdot f_3$ .

Conversely, if  $(j, i) \in f_1 \cdot f_2 \cdot f_3$ , then there exists  $u \in [m_j]$  and  $v \in [n_i]$  such that  $(j, m_1 + \dots + m_{j-1} + u) \in f_1$ ,  $f_2(m_1 + \dots + m_{j-1} + u) = n_1 + \dots + n_{i-1} + v$  and  $(n_1 + \dots + n_{i-1} + v, i) \in f_3$ . Using the definition of  $f_2$  we get  $(j, i) \in f$ , hence  $f_1 \cdot f_2 \cdot f_3 \subseteq f$ .

For (ii), let  $(k, k') \in f_2$  be such that  $(j, k) \in f_1$  and  $(k', i) \in f_3$ . From  $(j, k) \in f_1$  it follows that there exists  $u \in [m_j]$  such that  $k = m_1 + \dots + m_{j-1} + u$ . From  $(k', i) \in f_3$ , it

follows that there exists  $v \in [n_i]$  such that  $k' = n_1 + \dots + n_{i-1} + v$ . From the definition of  $f_2$  it follows that  $u = \text{card}\{(j, r) \in f : r \leq i\}$  and  $v = \text{card}\{(r, i) \in f : r \leq j\}$ . This shows that the pair  $(k, k')$  is unique with the required properties.

For (iii), let  $j \in [|a|]$ . The function  $(\top_{m_1 a_1 \oplus \dots \oplus m_{j-1} a_{j-1}} \oplus \top_{m_j a_j} \oplus \top_{m_{j+1} a_{j+1} \oplus \dots \oplus m_{|a|} a_{|a|}}) \cdot f_2$  is increasing due to the fact that all the pairs  $(j, i_1^j), \dots, (j, i_{m_j}^j)$  from the definition domain appear in the lower side of the rectangle in the same order. The other property follows in a similar way.

Finally, we show the decomposition of  $f$  is unique. Suppose  $f'_1 \cdot f'_2 \cdot f'_3$  is another decomposition of  $f$  fulfilling conditions (i), (ii) and (iii). Using (i) we get some numbers  $m'_j$  and  $n'_i$  such that  $f'_1 = \wedge_{m'_1}^{a_1} \oplus \dots \oplus \wedge_{m'_{|a|}}^{a_{|a|}}$  and  $f'_3 = \vee_{b'_1}^{n'_1} \oplus \dots \oplus \vee_{b'_{|b|}}^{n'_{|b|}}$ . Using (ii) we get  $m'_j = \text{card}\{i : (j, i) \in f\} = m_j, \quad \forall j \in [|a|]$  and similarly  $n'_i = n_i, \quad \forall i \in [|b|]$ . Finally, by (iii) we get  $f'_2 = f_2$ , hence the decomposition is unique.  $\square$

*Convention:* In order to shorten the formulas we write  $\sum_{i \in [n]} a_i$  instead of  $a_1 \oplus \dots \oplus a_n$ . Since the summation “ $\oplus$ ” is not a commutative operation, the sum may be meaningless. To avoid this ambiguity we use the convention that the indices are taken from a linearly ordered sets and summation is done in the increasing order of indices. When nothing else is said and the indices are numbers in  $\mathbb{N}$  the order in “less than”.

In the rest of this section we are looking for a connection between an arbitrary representation of  $f \in \mathbb{IRel}_S(a, b)$  and the standard one. For the standard representation of  $f$  we keep the notation used in the statement of Theorem 2.8.

**Theorem 2.9** *If  $f = f'_1 \cdot f'_2 \cdot f'_3$  is a representation of  $f \in \mathbb{IRel}_S(a, b)$ , where*

$$f'_1 = \sum_{j \in [|a|]} \wedge_{m'_j}^{a_j} \quad \text{and} \quad f'_3 = \sum_{i \in [|b|]} \vee_{b'_i}^{n'_i}$$

*then there exist*

$$h_j \in \mathbb{Bi}_S(m'_j a_j, m'_j a_j), \text{ for } j \in [|a|] \text{ and}$$

$$g_i \in \mathbb{Bi}_S(n'_i b_i, n'_i b_i), \text{ for } i \in [|b|]$$

*such that*

$$f = f'_1 \cdot \left[ \left( \sum_{j \in [|a|]} h_j \right) \cdot f_2 \cdot \left( \sum_{i \in [|b|]} g_i \right) \right] \cdot f'_3$$

*gives a representation of  $f$  which satisfies condition (iii) in Theorem 2.8.*

**Proof:** The problem clearly reduces to the following one: Show that for a usual bijection<sup>4</sup>

$$\phi \in \mathbb{Bi}(m_1 + \dots + m_r, n_1 + \dots + n_s)$$

there exists bijections

$$\sigma_j \in \mathbb{Bi}(m_j, m_j), \text{ for } j \in [r] \text{ and}$$

---

<sup>4</sup> $\mathbb{Bi}$  (without index) denotes the unsorted case, i.e.  $\mathbb{Bi}_S$  for an  $S$  with a unique element.

$$\tau_i \in \mathbb{Bi}(n_i, n_i), \text{ for } i \in [s]$$

such that the bijection

$$(\sigma_1 \oplus \dots \oplus \sigma_r) \cdot \phi \cdot (\tau_1 \oplus \dots \oplus \tau_s)$$

obeys the following conditions:

the restrictions to all sets  $A_j = m_1 + \dots + m_{j-1} + [m_j]$ ,  $j \in [r]$  are increasing functions and

the corestrictions to all sets  $B_i = n_1 + \dots + n_{i-1} + [n_i]$ ,  $i \in [s]$  are increasing partial functions.

The first step is easy. Since every injection may be made increasing by an appropriate permutations of the source elements, i.e.

$$\forall f \in \mathbb{In}(m, n) \quad \exists g \in \mathbb{Bi}(m, m) \text{ such that } g \cdot f \text{ is an increasing function}$$

we find bijections  $\sigma_j \in \mathbb{Bi}(m_j, m_j)$  such that for every  $j \in [r]$  the restriction to  $A_j$  of the bijection  $(\sigma_1 \oplus \dots \oplus \sigma_r) \cdot \phi$  is an increasing function.

Next, we apply the same procedure to the cosource. Since every converse of injection may be done increasing by an appropriate permutation of the cosource elements, i.e.,

$$\forall f \in \mathbb{In}^{-1}(m, n) \quad \exists g \in \mathbb{Bi}(n, n) \text{ such that } f \cdot g \text{ is an increasing partial functions}$$

we find bijections  $\tau_i \in \mathbb{Bi}(n_i, n_i)$  such that for every  $i \in [s]$  the corestriction to  $B_i$  of the bijection  $\psi = [(\sigma_1 \oplus \dots \oplus \sigma_r) \cdot \phi] \cdot (\tau_1 \oplus \dots \oplus \tau_s)$  is an increasing partial function.

The only problem is to show that the last transformation preserves the first property, i.e. it produces a function  $\psi$  such that for every  $i \in [s]$ , the restriction of  $\psi$  to  $A_j$  is still increasing. In order to prove this, take an arbitrary  $j \in [r]$  and arbitrary  $u, v \in A_j$  such that  $u < v$ . There are two cases:

- (i) Suppose both elements  $[(\sigma_1 \oplus \dots \oplus \sigma_r) \cdot \phi](u)$  and  $[(\sigma_1 \oplus \dots \oplus \sigma_r) \cdot \phi](v)$  belong to the same set, say  $B_i$ , for an  $i \in [s]$ . It follows that  $\phi(u) \in B_i$  and  $\phi(v) \in B_i$ . Since  $u < v$  and the corestriction of  $\phi$  to  $B_i$  is increasing, we get  $\phi(u) < \phi(v)$ .
- (ii) Suppose there are two indices  $i \neq i'$  in  $[s]$  such that  $[(\sigma_1 \oplus \dots \oplus \sigma_r) \cdot \phi](u) \in B_i$  and  $[(\sigma_1 \oplus \dots \oplus \sigma_r) \cdot \phi](v) \in B_{i'}$ . Since  $(\sigma_1 \oplus \dots \oplus \sigma_r) \cdot \phi$  is increasing on  $A_j$  it follows that  $i < i'$ . So,  $i < i'$ ,  $\psi(u) \in B_i$  and  $\psi(v) \in B_{i'}$ , hence  $\psi(u) < \psi(v)$ .

Now the statement of the theorem follows from the property just proved and the identities  $\wedge_{m'_j}^{a_j} \cdot h_j = \wedge_{m'_j}^{a_j}$ , for  $j \in [|a|]$  and  $g_i \cdot \vee_{b_i}^{n'_j} = \vee_{b_i}^{n'_j}$ , for  $i \in [|b|]$ . [In a degenerate case  $m'_j = 0$  (resp.  $n'_i = 0$ ) we take  $h_j = \text{l}_0$  (resp.  $g_i = \text{l}_0$ ).]  $\square$

The importance of property (iii) comes from the following fact: If a representation  $f = f'_1 \cdot f'_2 \cdot f'_3$  as in Theorem 2.8 satisfies condition (iii), then all the arrows of  $f'_2$  belonging to paths connecting two elements  $j$  and  $i$  are parallel and grouped one near the other. More precisely, if for  $j \in [|a|]$  and  $i \in [|b|]$  we denote by

$$p_{j,i} = \text{card}\{(k, k') \in f'_2 : (j, k) \in f'_1 \text{ and } (k', i) \in f'_3\}$$

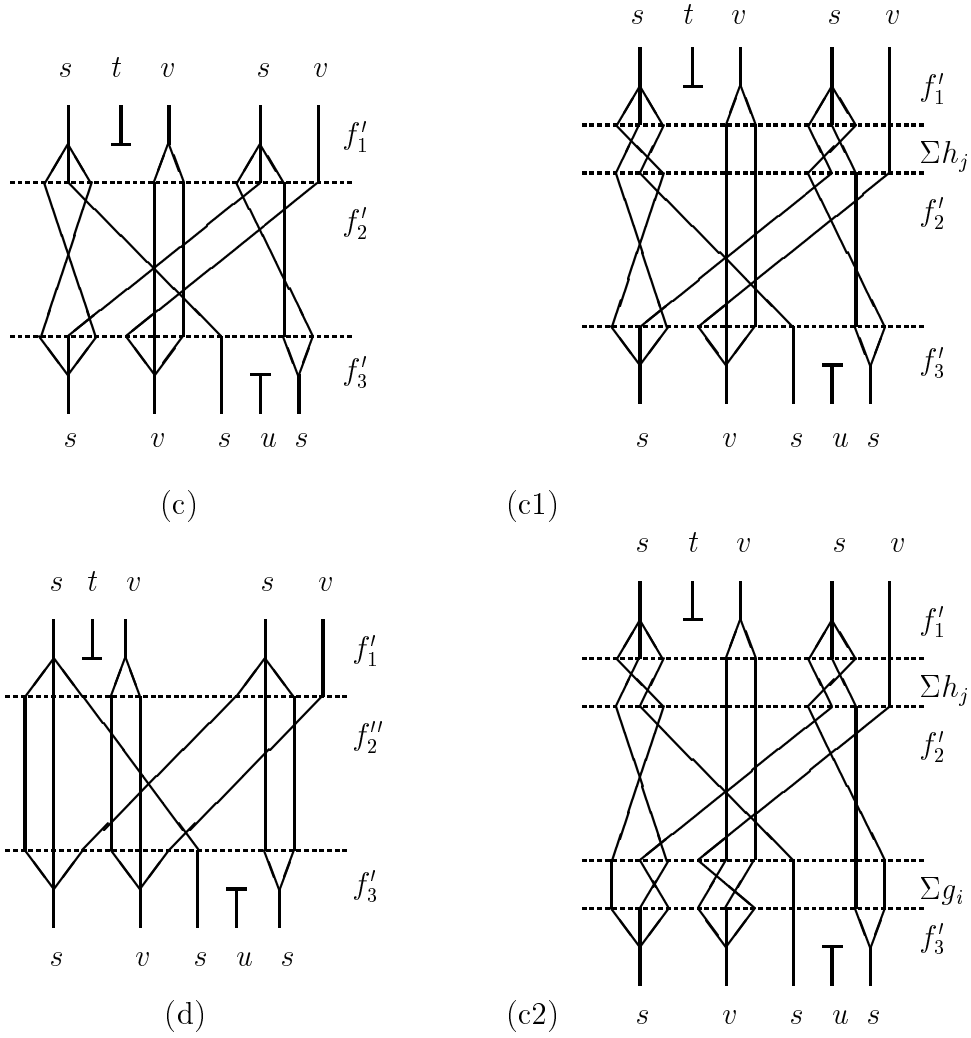

Figure 2.5: An arbitrary representation (c) of the relation in Figure 2.3.(a) and the steps (c1) & (c2) towards a representation (d) obeying (iii) of Theorem 2.8. (See Theorem 2.9)

then we get

$$f'_2 \left( \sum_{t \in [j-1]} m'_t + \sum_{t \in [i-1]} p_{j,t} + k \right) = \sum_{t \in [i-1]} n'_t + \sum_{t \in [j-1]} p_{t,i} + k, \quad \forall k \in [p_{j,i}].$$

This property shows that  $f'_2$  may be obtained from  $f_2$  by a multiplication of arrows. For example, in Figure 2.5 we have

$$f''_2 = (1_2 5_1 3_2 2_1 6_2 4_1)$$

while

$$f_2 = (1_1 5_1 3_1 2_1 6_1 4_1)$$

We shall express this in a theorem, but we need a notation to state it.

**Notation 2.10** ( $f_{\prec}, f_{\prec}^{j,i}; f_{\prec^a}, f_{\prec^a}^{j,i}$ )

We denote by  $f_{\prec}$  the  $\prec$ -ordered set of all the pairs in  $f$  and by  $f_{\prec}^{j,i}$  the number of the pair  $(j, i)$  in  $f_{\prec}$ , counted in the increasing order.

Similarly we define  $f_{\prec^a}$  and  $f_{\prec^a}^{j,i}$  by using the order  $\prec^a$ .  $\square$

Let us note that with this notation the definition of  $f_2$  from the standard representation of  $f$  becomes simple:

$$f_2(f_{\prec}^{j,i}) = f_{\prec^a}^{j,i}$$

Moreover, with the notation introduced before Proposition 2.7 we have

$$f_2 = (\dots (f_{\prec^a}^{j,i})_{a_j} \dots),$$

where the generic term is indexed by  $(j, i)$  and this pair varies increasingly in  $f_{\prec}$ .

**Theorem 2.11** Suppose  $f = f_1 \cdot f_2 \cdot f_3$  is the standard representation of  $f \in \mathbb{R}\text{el}_S(a, b)$  and  $p_{j,i} = \text{card}\{(k, k') \in f_2' : (j, k) \in f_1' \text{ and } (k', i) \in f_3'\}$ .

If  $f = f_1' \cdot f_2' \cdot f_3'$  is a representation of  $f$  which satisfies condition (iii) and  $f_1' = \sum_{j \in [|a|]} \wedge_{m_j}^{a_j}$ ,  $f_3' = \sum_{i \in [|b|]} \vee_{b_i}^{n_i}$ , then

$$f_2' = (\dots (f_{\prec^a}^{j,i})_{p_{j,i} a_j} \dots)$$

where the generic term is indexed by  $(j, i)$  and this pair varies increasingly in  $f_{\prec}$ .  $\square$

Actually, this shows that  $f_2'$  is the extension of  $f_2$  obtained by multiplying of  $p_{j,i}$  times the arrow going from the pair  $(j, i)$ .

Finally, let us note that with the above notation the identity in Proposition 2.7 (applied for  $f_2$  and the morphisms  $g_{j,i} : a_{j,i} \rightarrow b_{j,i}$  for  $(j, i) \in f$ ) may be written as:

$$\left( \sum_{(j,i) \in f_{\prec}} g_{j,i} \right) \cdot (\dots (f_{\prec^a}^{j,i})_{b_{j,i}} \dots) = (\dots (f_{\prec^a}^{j,i})_{a_{j,i}} \dots) \cdot \left( \sum_{(j,i) \in f_{\prec^a}} g_{j,i} \right)$$

## 2.4 A universal theorem for $xy$ - $\mathbb{R}\text{el}_S$

The theorem we shall prove in this section is about the structures  $xy$ - $\mathbb{R}\text{el}_S$ , where  $x \in \{a, b, c, d\}$  and  $y \in \{\alpha, \beta, \gamma, \delta\}$  are two parameters as in Table 2.2. We may suppose  $xy \neq a\alpha$  since the corresponding theorem in the case  $x = a$  and  $y = \alpha$  was proved before (Theorem 2.5).

In the sequel we shall use the bijection<sup>5</sup>  $\varphi_{m,n}^s : m(ns) \rightarrow n(ms)$  given by

- $\varphi_{0,n}^s = \varphi_{m,0}^s = \text{id}$ ;
- if  $m \geq 1, n \geq 1$ , then for  $i \in [m], j \in [n]$

$$\varphi_{m,n}^s(m(i-1) + j) = n(j-1) + i$$

**Definition 2.12** ( $xy$ -object)

Let  $B$  be a ssms. We say an object  $a$  in  $B$  is an  $xy$ -object if for every  $m$  satisfying restriction  $x$  and every  $n$  satisfying restriction  $y$  there are given morphisms  $\wedge_m^a \in B(a, ma)$  and  $\vee_a^n \in B(na, a)$  such that the conditions in Table 2.4 hold.  $\square$

Table 2.4: Axioms for  $xy$ -objects written with the extended constants  $\wedge_m^a$  and  $\vee_a^n$ .

---

IP0	$\vee_a^1 = \wedge_1^a = \text{id}_a$ .
IP1	$\wedge_m^a \cdot (\sum_{j \in [m]} \wedge_{m_j}^a) = \wedge_{\sum_{j \in [m]} m_j}^a$ if $m$ and $m_j$ , for $j \in [m]$ satisfy restriction $x$ ; $(\sum_{i \in [n]} \vee_a^{n_i}) \cdot \vee_a^n = \vee_a^{\sum_{i \in [n]} n_i}$ if $n$ and $n_i$ , for $i \in [n]$ satisfy restriction $y$ .
If $F : \mathbb{B}i_S \rightarrow B$ is a morphism of ssmc's such that $F(s) = a$ for an $s \in S$ , then:	
IP2	$\wedge_m^a \cdot F(f) = \wedge_m^a$ for every $f \in \mathbb{B}i_S(ms, ns)$ , if $m$ satisfies restriction $x$ ; $F(f) \cdot \vee_a^n = \vee_a^n$ for every $f \in \mathbb{B}i_S(na, na)$ , if $n$ satisfies restriction $y$ ;
IP3	$\vee_a^n \cdot \wedge_m^a = (\sum_{i \in [n]} \wedge_m^a) \cdot F(\varphi_{n,m}^s) \cdot (\sum_{i \in [m]} \vee_a^n)$ , if $m$ and $n$ satisfy the restrictions $x$ and $y$ , respectively.
IP4	$\wedge_n^a \cdot \vee_a^n = \text{id}_a$ , if $n \geq 1$ and $n$ satisfies the restrictions $x$ and $y$ .

---

It is easy to check that in the categories  $xy\text{-Rel}_S$  every object is an  $xy$ -object.

**Theorem 2.13** *Let  $xy$  be a restriction and  $B$  a ssmc.*

*If  $h : S^* \rightarrow \mathcal{O}(B)$  is a function which maps every  $s \in S$  to an  $xy$ -object  $h(s)$  in  $B$ , then there exists a unique morphism of ssmc's  $H : xy\text{-Rel}_S \rightarrow B$  such that for every  $s \in S$ :*

- $H(s) = h(s)$ ;
- $H(\wedge_m^s) = \wedge_{h(s)}^{h(s)}$ , for every  $m$  satisfying restriction  $x$ ; and
- $H(\vee_s^n) = \vee_{h(s)}^n$ , for every  $n$  satisfying restriction  $y$ .

**Proof:** By Theorem 2.5 there exists a unique ssmc-morphism  $F : \mathbb{B}i_S \rightarrow B$  whose restriction to objects agrees with  $h$ . For every  $xy$ -relation  $f \in xy\text{-Rel}_S(a, b)$  and every representation of it

$$f = (\sum_{j \in [|a|]} \wedge_{m'_j}^{a_j}) \cdot f'_2 \cdot (\sum_{i \in [|b|]} \vee_{b'_i}^{n'_i})$$

such that  $f'_2 \in \mathbb{B}i_S$ , all  $m'_j$  obey  $x$  and all  $n'_i$  obey  $y$

we define  $H(f) := E$ , where

$$E = (\sum_{j \in [|a|]} \wedge_{m'_j}^{h(a_j)}) \cdot F(f'_2) \cdot (\sum_{i \in [|b|]} \vee_{h(b'_i)}^{n'_i})$$

The first problem is to show the definition is correct. It is easy to see that the definition works for all  $xy$ -relations. Much more complicated is the proof that the result does not

---

<sup>5</sup>It naturally rearranges  $m$  groups of  $n$  elements in  $n$  groups of  $m$  elements.



depend on the the particular representation we choose. To this end we use the standard representation of  $f$ , i.e.

$$f = (\sum_{j \in [|a|]} \wedge_{m_j}^{a_j}) \cdot f_2 \cdot (\sum_{i \in [|b|]} \vee_{b_i}^{n_i})$$

(Since  $f$  is an  $xy$ -relation, it follows that all the indices  $m_j$  obey restriction  $x$  and all  $n_i$  obey restriction  $y$ .)

Let  $f = f'_1 \cdot f'_2 \cdot f'_3$  be a representation of  $f$  as in the above definition of  $H$ . Using Theorem 2.9 we find bijections  $h_j \in \mathbb{B}i_S(m'_j a_j, m'_j a_j)$ , for  $j \in [|a|]$  and  $g_i \in \mathbb{B}i_S(n'_i b_i, n'_i b_i)$ , for  $i \in [|b|]$  such that the representation

$$f = f'_1 \cdot f'_2 \cdot f'_3$$

fulfills condition (iii) in Theorem 2.8, where  $f''_2 = (\sum_{j \in [|a|]} h_j) \cdot f'_2 \cdot (\sum_{i \in [|b|]} g_i)$ .

Using IP2 it follows that

$$\begin{aligned} E &= (\sum_{j \in [|a|]} \wedge_{m'_j}^{h(a_j)} \cdot F(h_j)) \cdot F(f'_2) \cdot (\sum_{i \in [|b|]} F(g_i) \cdot \vee_{h(b_i)}^{n'_i}) \\ &= (\sum_{j \in [|a|]} \wedge_{m'_j}^{h(a_j)}) \cdot F(f''_2) \cdot (\sum_{i \in [|b|]} \vee_{h(b_i)}^{n'_i}) \end{aligned}$$

Denote

$$p_{j,i} = \text{card}\{(k, k') \in f''_2 : (j, k) \in f'_1 \text{ and } (k', i) \in f'_3\}$$

For  $(j, i) \in f$  we have  $1 \leq p_{j,i} \leq \min\{m'_j, n'_i\}$ , hence  $p_{j,i}$  obeys restrictions  $x$  and  $y$ . Using Theorem 2.11 we get

$$\begin{aligned} E &= (\sum_{j \in [|a|]} \wedge_{m'_j}^{h(a_j)} \cdot (\sum_{i \in f(j)} \wedge_{p_{j,i}}^{h(a_j)})) \cdot F(f''_2) \cdot (\sum_{i \in [|b|]} (\sum_{j \in f^{-1}(i)} \vee_{b_i}^{p_{j,i}}) \cdot \vee_{h(b_i)}^{n_i}) \\ &= (\sum_{j \in [|a|]} \wedge_{m'_j}^{h(a_j)}) \cdot (\sum_{(j,i) \in f \prec} \wedge_{p_{j,i}}^{h(a_j)}) \cdot (\dots (f_{\prec a}^{j,i})_{p_{j,i} h(a_j)} \dots) \\ &\quad \cdot (\sum_{(j,i) \in f \prec a} \vee_{h(b_i)}^{p_{j,i}}) \cdot (\sum_{i \in [|b|]} \vee_{h(b_i)}^{n_i}) \end{aligned}$$

Using Proposition 2.7 (in the form that has been written below Theorem 2.11 ) we get

$$(\sum_{(j,i) \in f \prec} \wedge_{p_{j,i}}^{h(a_j)}) \cdot (\dots (f_{\prec a}^{j,i})_{p_{j,i} h(a_j)} \dots) = F(f_2) \cdot (\sum_{(j,i) \in f \prec a} \wedge_{p_{j,i}}^{h(a_j)})$$

By replacing this in the above expression we get

$$E = (\sum_{j \in [|a|]} \wedge_{m'_j}^{h(a_j)}) \cdot F(f_2) \cdot (\sum_{(j,i) \in f \prec a} \wedge_{p_{j,i}}^{h(a_j)} \cdot \vee_{h(b_i)}^{p_{j,i}}) \cdot (\sum_{i \in [|b|]} \vee_{h(b_i)}^{n_i})$$

Finally,  $a_j = b_i$ , for every  $(j, i) \in f$ , hence by IP4 we get

$$E = (\sum_{j \in [|a|]} \wedge_{m'_j}^{h(a_j)}) \cdot F(f_2) \cdot (\sum_{i \in [|b|]} \vee_{h(b_i)}^{n_i})$$

and this shows the definition of  $H$  does not depend on the representation  $f = f'_1 \cdot f'_2 \cdot f'_3$  we have started with.

Using the standard representation for an  $f \in \mathbb{B}i_S(a, b)$  and IP0 we get

$$H(f) = F(f)$$

i.e.,  $H$  extends  $F$ . Moreover, it is also easy to see that

$$H(\wedge_m^s) = \wedge_m^{h(s)}$$

for an  $m$  obeying restriction  $x$  and

$$H(\vee_s^n) = \vee_{h(s)}^n$$

for an  $n$  obeying restriction  $y$ .

Next, we show  $h$  commutes with the operations. In order to prove

$$H(f \cdot g) = H(f) \cdot H(g)$$

for  $f \in xy\text{-Rel}_S(a, b)$  and  $g \in xy\text{-Rel}_S(b, c)$  we use the standard representation of  $f$  with the notations in Theorem 2.8 and the standard representation of  $g$ , i.e.,

$$g = g_1 \cdot g_2 \cdot g_3$$

where  $g_1 = \sum_{i \in [|b|]} \wedge_{m'_i}^{b_i}$ ,  $g_2$  is from  $\text{IBi}_S$  and  $g_3 = \sum_{k \in [|c|]} \vee_{c_k}^{n'_k}$ . We have,

$$\begin{aligned} H(f) \cdot H(g) &= (\sum_{j \in [|a|]} \wedge_{m'_j}^{h(a_j)}) \cdot F(f_2) \cdot (\sum_{i \in [|b|]} \vee_{h(b_i)}^{n_i}) \\ &\quad \cdot (\sum_{i \in [|b|]} \wedge_{m'_i}^{h(b_i)}) \cdot F(g_2) \cdot (\sum_{k \in [|c|]} \vee_{h(c_k)}^{n'_k}) \end{aligned}$$

Applying IP3 we get

$$\begin{aligned} &(\sum_{i \in [|b|]} \vee_{h(b_i)}^{n_i}) \cdot (\sum_{i \in [|b|]} \wedge_{m'_i}^{h(b_i)}) \\ &= (\sum_{(j,i) \in f_{\prec a}} \wedge_{m'_i}^{h(b_i)}) \cdot (\sum_{i \in [|b|]} F(\varphi_{n_i, m'_i}^{b_i})) \cdot (\sum_{(i,k) \in g_{\prec}} \vee_{h(b_i)}^{n_i}) \end{aligned}$$

Replacing this in the above identity and using Observation A.5 (as in the proof of the definition correctness) we get

$$\begin{aligned} H(f) \cdot H(g) &= (\sum_{j \in [|a|]} \wedge_{m'_j}^{h(a_j)}) \cdot (\sum_{(j,i) \in f_{\prec}} \wedge_{m'_i}^{h(b_i)}) \\ &\quad \cdot (\dots (f_{\prec a}^{j,i})_{m'_i h(b_i)} \dots) \cdot (\sum_{i \in [|b|]} F(\varphi_{n_i, m'_i}^{b_i})) \cdot (\dots (g_{\prec a}^{i,k})_{n_i h(b_i)} \dots) \\ &\quad \cdot (\sum_{(i,k) \in g_{\prec}} \vee_{h(b_i)}^{n_i}) \cdot (\sum_{k \in [|c|]} \vee_{h(c_k)}^{n'_k}) \end{aligned}$$

Since  $a_j = b_i$  for all  $(j, i) \in f$  and  $b_i = c_k$  for all  $(i, k) \in g$ , with IP1 we get

$$\begin{aligned} (*) \quad H(f) \cdot H(g) &= (\sum_{j \in [|a|]} \wedge_{\sum_{\{i: (j,i) \in f\}} m'_i}^{h(a_j)}) \\ &\quad \cdot F([\dots (f_{\prec a}^{j,i})_{m'_i b_i} \dots] \cdot (\sum_{i \in [|b|]} \varphi_{n_i, m'_i}^{b_i}) \cdot (\dots (g_{\prec a}^{i,k})_{n_i b_i} \dots)]) \\ &\quad \cdot (\sum_{k \in [|c|]} \vee_{h(c_k)}^{\sum_{\{i: (i,k) \in g\}} n_i}) \end{aligned}$$

By a case analysis for  $x \in \{a, b, c, d\}$ , it is easy to see that the all the sums above  $\sum_{\{i: (j,i) \in f\}} m'_i$  satisfy restriction  $x$ . Similarly, all the sums  $\sum_{\{i: (i,k) \in g\}} n_i$  satisfy restriction  $y$ .

Now we have arrived to the end of the proof of commutation with composition. The above deduction holds true in every  $xy\text{-ssmc}$ , hence in  $xy\text{-Rel}_S$ , too. Applying (\*) for  $h = \mathbf{id}_{S^*}$ , —in which case,  $H = \mathbf{id}_{xy\text{-Rel}_S}$ —, we get a representation of  $f \cdot g$ . From the definition of  $H$  it follows that the right hand side of (\*) represents an expression equal to  $H(f \cdot g)$ . Hence

$$H(f \cdot g) = H(f) \cdot H(g)$$

The proof of the commutation with summation is fairly simple and it is omitted.  $\square$

## 2.5 The analysis of conditions IP1–IP4

The aim of this section is to simplify as much as possible the conditions IP1–IP4 used in Table 2.4. This way we get simple presentations for  $xy\text{-IRel}_S$ . Actually, we prove that axioms A–G and  $A^o\text{--}D^o$  in Table 2.1, which are particular instances of the conditions IP1–IP4, are enough to imply the validity of IP1–IP4 in all cases.

Let  $a$  be an object in a ssmc  $B$ . The main idea is to replace the general constants  $\Lambda_m^a$  and  $\nabla_a^n$  with their particular instances  $\Lambda_0^a$  (denoted  $\perp^a$ ),  $\Lambda_2^a$  (denoted  $\wedge^a$ ),  $\nabla_a^0$  (denoted  $\top_a$ ), and  $\nabla_a^2$  (denoted  $\vee_a$ ). In terms of these constants the previous general ones  $\Lambda_m^a$  and  $\nabla_a^n$  may be inductively defined by

$$\Lambda_{m+1}^a = \wedge^a \cdot (\Lambda_m^a \oplus \mathbb{1}_a) \qquad \nabla_a^{n+1} = (\nabla_a^n \oplus \mathbb{1}_a) \cdot \vee_a$$

These definitions are used in the cases  $x \in \{c, d\}$  and  $y \in \{\gamma, \delta\}$ , respectively.

*In this section we shall prove that the axioms A–G and  $A^o\text{--}D^o$  in Table 2.1 characterize a  $d\delta$ -object; in general an  $xy$ -object is characterized by the axioms in column 5 of Table 2.3 that have no  $SV$  or  $SV^o$  type.*

If  $x = d$  (resp.  $y = \delta$ ) the first step in the inductive definition is  $\Lambda_0^a = \perp^a$  (resp.  $\nabla_a^0 = \top_a$ ). In this case one may use axiom  $C^o$  (resp. C) in order to prove IP0. In the other cases IP0 follows from the definition: that is,  $\Lambda_1^a = \mathbb{1}_a$  (resp.  $\nabla_a^1 = \mathbb{1}_a$ ) is the basis of the inductive definition in the case  $x = c$  (resp.  $y = \gamma$ ). Let us note that IP0 implies  $\Lambda_2^a = \wedge^a$  and  $\nabla_a^2 = \vee_a$ .

We have to study 60 variants = 4 conditions  $\times$  15 cases.<sup>6</sup> The study is reduced to 7 cases using the following simplifications.

a) *Duality.*

**Definition 2.14** (duality)

By duality we mean the process of transformation of statements with respect to the following rules:

$$\begin{aligned} f \cdot g & \text{ is replaced by } g \cdot f, \\ {}^a\mathbf{X}^b & \text{ is replaced by } {}^b\mathbf{X}^a, \\ \Lambda_n^a & \text{ is replaced by } \nabla_a^n \qquad \nabla_a^n & \text{ is replaced by } \Lambda_n^a, \\ f \oplus g \text{ and } \mathbb{1}_a & \text{ remain unchanged.} \end{aligned}$$

This means, we use the duality from the category theory extended in a natural way to the other operations.  $\square$

First we note that the ssmc structure is selfdual. The second identity in IP1 (resp. IP2) is dual with the first one. Since by duality the restrictions  $a, b, c, d$  have to be interchanged with  $\alpha, \beta, \gamma, \delta$ , respectively, we may reduce the study to 9 cases:  $a\beta, a\gamma, a\delta, b\beta, b\gamma, b\delta, c\gamma, c\delta, d\delta$ . For example, by duality a result about case  $b\gamma$  produces a result about case  $c\beta$ .

b) If an identity in condition IP $i$  contains only constants  $\Lambda_m$  (resp.  $\nabla^n$ ), then its study may be reduced to the cases  $x\alpha$  (resp.  $ay$ ). This reduction may be applied to conditions IP1 and IP2.

---

<sup>6</sup>The  $aa$  case is covered by Theorem 2.5.

c) If an identity in a condition  $IP_i$  has all the occurrences of the constants  $\wedge_m$  (resp.  $\vee^n$ ) to the same power  $m$  (resp.  $n$ ), then its study in the case  $dy$  (resp.  $x\delta$ ) may be reduced to its study in the cases  $by$  and  $cy$  (resp.  $x\beta$  and  $x\gamma$ ). This reduction applies to IP2, IP3 and IP4.

**Analysis of IP1.** By using the above reductions a) and b) we may reduce the study of IP1 to the study of the second identity in IP1 and this in cases  $a\beta$ ,  $a\gamma$  and  $a\delta$  only. Since for  $n \in \{0, 1\}$  the second identity in IP1 holds, the case  $a\beta$  is over. Hence we have to prove *the second identity in IP1 in cases  $a\gamma$  and  $a\delta$ .*

**Lemma 2.15** *The second identity in IP1 in the case  $a\gamma$  follows from axiom A in Table 2.1.*

**Proof:** For  $n = 1$  the equality obviously holds. For  $n = 2$  we have to prove that

$$(\vee_a^i \oplus \vee_a^j) \cdot \vee_a = \vee_a^{i+j}$$

for every  $i, j \geq 1$ . We prove this by induction on  $j$ . The case  $j = 1$  follows by definition. The inductive step follows using axiom A and the inductive hypothesis in

$$\begin{aligned} (\vee_a^i \oplus \vee_a^{j+1}) \cdot \vee_a &= (\vee_a^i \oplus \vee_a^j \oplus l_a) \cdot (l_a \oplus \vee_a) \cdot \vee_a \\ &= (\vee_a^i \oplus \vee_a^j \oplus l_a) \cdot (\vee_a \oplus l_a) \cdot \vee_a \\ &= (\vee_a^{i+j} \oplus l_a) \cdot \vee_a \\ &= \vee_a^{i+j+1} \end{aligned}$$

For  $n \geq 3$  using the inductive hypothesis we see that

$$\begin{aligned} (\sum_{i \in [n]} \vee_a^{k_i}) \cdot \vee_a^n &= (\sum_{i \in [n-1]} \vee_a^{k_i} \oplus \vee_a^{k_n}) \cdot (\vee_a^{n-1} \oplus l_a) \cdot \vee_a \\ &= (\vee_a^{\sum_{i \in [n-1]} k_i} \oplus \vee_a^{k_n}) \cdot \vee_a \\ &= \vee_a^{\sum_{i \in [n]} k_i} \end{aligned}$$

□

**Lemma 2.16** *The second identity in IP1 in the case  $a\delta$  follows from axioms A, B and C.*

**Proof:** Using axiom B in C we get

$$(l_a \oplus \top_a) \cdot \vee_a = l_a$$

Now the proof of this lemma is similar to the proof of the above one, with the difference that each induction starts with 0.

For  $n = 0$  it is clear (the empty sum is  $l_0$ ). In the case  $n = 2$ , the starting step  $j = 0$  follows by

$$\begin{aligned} (\vee_a^i \oplus \vee_a^0) \cdot \vee_a &= (\vee_a^i \oplus l_0) \cdot (l_a \oplus \top_a) \cdot \vee_a \\ &= \vee_a^i \end{aligned}$$

□

**Analysis of IP2.** As in the above analysis of IP1 the study is reduced to the second identity in cases  $a\gamma$  and  $a\delta$ . By reduction c), case  $a\delta$  is reduced to cases  $a\beta$  and  $a\gamma$ . Hence we still have to prove *the second identity in IP2 in case  $a\gamma$ .*

**Lemma 2.17** *The second identity in IP2 in case  $a\gamma$  follows from axioms A and B.*

**Proof:** Every bijection  $f \in \mathbb{B}is(ns, ns)$  may be written as a composition of bijections of the type

$$l_{is} \oplus {}^sX^s \oplus l_{(n-i-2)s}$$

where  $0 \leq i \leq n-2$ . Hence it is enough to prove the statement in the lemma for this type of bijections. This follows by

$$\begin{aligned} (l_{ia} \oplus {}^aX^a \oplus l_{(n-i-2)a}) \cdot V_a^n &= (l_{ia} \oplus {}^aX^a \oplus l_{(n-i-2)a}) \cdot (l_{ia} \oplus V_a \oplus l_{(n-i-2)a}) \cdot V_a^{n-1} \\ &= (l_{ia} \oplus V_a \oplus l_{(n-i-2)a}) \cdot V_a^{n-1} \\ &= V_a^n \end{aligned}$$

□

**Analysis of IP3.** In the case  $m = 1$ , IP3 holds. By duality we reduce the study to six cases:  $b\beta$ ,  $b\gamma$ ,  $b\delta$ ,  $c\gamma$ ,  $c\delta$ ,  $d\delta$ . Finally, using reduction c) the problem is reduced to the study of IP3 *in cases  $b\beta, b\gamma$  and  $c\gamma$ .*

**Lemma 2.18** *Condition IP3 in case  $b\beta$  follows from axiom B.*

**Proof:** In the case  $n = 1$  or  $m = 1$ , property IP3 obviously holds. The case left open  $m = 0 = n$  follows from axiom E. □

**Lemma 2.19** *Condition IP3 in case  $b\gamma$  follows from axiom D.*

**Proof:** The case  $m = 1$  clearly holds. In the case  $m = 0$ , by induction on  $n$  it follows that

$$\begin{aligned} V_a^{n+1} \cdot \perp^a &= (V_a^n \oplus l_a) \cdot V_a \cdot \perp^a \\ &= (V_a^n \oplus l_a) \cdot (\perp^a \oplus \perp^a) \\ &= \sum_{i \in [n]} \perp^a \oplus \perp^a \\ &= \sum_{i \in [n+1]} \perp^a \end{aligned}$$

□

**Lemma 2.20** *Condition IP3 in case  $c\gamma$  follows from axiom F.*

**Proof:** We prove IP3 using an induction on  $n+m$ , for pairs  $(n, m)$  with  $m \geq 2$  and  $n \geq 2$ .

The case  $(2, 2)$  follows from axiom F. The case  $(2, m+1)$  may be reduced to the case  $(1, m)$  as follows

$$\begin{aligned} V_a^2 \cdot \wedge_{m+1}^a &= V_a \wedge^a (\wedge_m^a \oplus l_a) \\ &= (\wedge^a \oplus \wedge^a) (l_a \oplus {}^aX^a \oplus l_a) (V_a \oplus V_a) (\wedge_m^a \oplus l_a) \\ &= (\wedge^a \oplus \wedge^a) (l_a \oplus {}^aX^a \oplus l_a) [(\wedge_m^a \oplus \wedge_m^a) F(\varphi_{2,m}^s) (\sum_{i \in [m]} V_a) \oplus V_a] \\ &= (\wedge^a \oplus \wedge^a) (\wedge_m^a \oplus {}^aX^a (\wedge_m^a \oplus l_a) \oplus l_a) (F(\varphi_{2,m}^s) \oplus l_{2a}) (\sum_{i \in [m+1]} V_a) \\ &= (\wedge^a \oplus \wedge^a) (\wedge_m^a \oplus l_a \oplus \wedge_m^a \oplus l_a) (l_{ma} \oplus {}^aX^{ma} \oplus l_a) (F(\varphi_{2,m}^s) \oplus l_{2a}) (\sum_{i \in [m+1]} V_a) \\ &= (\wedge_{m+1}^a \oplus \wedge_{m+1}^a) F((l_{ms} \oplus {}^sX^{ms} \oplus l_s) (\varphi_{2,m}^s) \oplus l_{2s}) (\sum_{i \in [m+1]} V_a) \\ &= (\sum_{i \in [2]} \wedge_{m+1}^a) F(\varphi_{2,m+1}^s) (\sum_{i \in [m+1]} V_a) \end{aligned}$$

Finally, the case  $(n + 1, m)$  with  $n \geq 2$  may be reduced the the cases  $(2, m)$  and  $(n, m)$  as follows

$$\begin{aligned}
V_a^{n+1} \cdot \wedge_m^a &= (V_a^n \oplus I_a) \vee_a \wedge_m^a \\
&= (V_a^n \oplus I_a) (\wedge_m^a \oplus \wedge_m^a) F(\varphi_{2,m}^s) (\sum_{i \in [m]} V_a) \\
&= [(\sum_{i \in [n]} \wedge_m^a) F(\varphi_{n,m}^s) (\sum_{i \in [m]} V_a^n \oplus \wedge_m^a) F(\varphi_{2,m}^s) (\sum_{i \in [m]} V_a) \\
&= (\sum_{i \in [n+1]} \wedge_m^a) (F(\varphi_{n,m}^s) \oplus I_{ma}) (\sum_{i \in [m]} V_a^n \oplus I_{ma}) F(\varphi_{2,m}^s) (\sum_{i \in [m]} V_a)
\end{aligned}$$

Here we make a pause to prove that

$$(\sum_{i \in [m]} V_a^n \oplus I_{ma}) \cdot F(\varphi_{2,m}^s) = F(\psi_m) \cdot (\sum_{i \in [m]} (V_a^n \oplus I_a))$$

where  $m, n \geq 1$  and  $\psi \in \text{Bi}_S(m(ns) + ms, m((n + 1)s))$  is defined by

$$\begin{aligned}
\psi_m(in + k) &= i(n + 1) + k, \quad \text{if } 0 \leq i < m \text{ and } k \in [n] \text{ and} \\
\psi_m(mn + i) &= i(n + 1), \quad \text{if } i \in [m]
\end{aligned}$$

First note that

$$\begin{aligned}
\psi_1 &= I_{(n+1)s} \\
\varphi_{2,m+1}^s &= (I_{ms} \oplus {}^s X^{ms} \oplus I_s) \cdot (\varphi_{2,m}^s \oplus I_{2s}) \text{ and} \\
(I_{m(ns)} \oplus {}^{ns} X^{ms} \oplus I_s) \cdot (\psi_m \oplus I_{(n+1)s}) &= \psi_{m+1}
\end{aligned}$$

The proof follows by induction on  $m$ . The inductive step looks as follows (in the third step we shall apply the inductive hypothesis)

$$\begin{aligned}
&(\sum_{i \in [m+1]} V_a^n \oplus I_{(m+1)a}) \cdot F(\varphi_{2,m+1}^s) \\
&= [\sum_{i \in [m]} V_a^n \oplus (V_a^n \oplus I_{ma}) \cdot {}^a X^{ma} \oplus I_a] (F(\varphi_{2,m}^s) \oplus I_{2a}) \\
&= (I_{m(na)} \oplus {}^{na} X^{ma} \oplus I_a) [(\sum_{i \in [m]} V_a^n \oplus I_{ma}) F(\varphi_{2,m}^s) \oplus V_a^n \oplus I_a] \\
&= F((I_{m(ns)} \oplus {}^{ns} X^{ms} \oplus I_s)(\psi_m \oplus I_{(n+1)s})) \cdot (\sum_{i \in [m+1]} (V_m^n \oplus I_a)) \\
&= F(\psi_{m+1}) \cdot (\sum_{i \in [m+1]} (V_m^n \oplus I_a))
\end{aligned}$$

Now we may finish the stoped proof. Using  $(\varphi_{n,m}^s \oplus I_{ms}) \cdot \psi_m = \varphi_{n+1,m}^s$  we get

$$\begin{aligned}
V_a^{n+1} \cdot \wedge_m^a &= (\sum_{i \in [n+1]} \wedge_m^a) F((\varphi_{n,m}^s \oplus I_{ms}) \psi_m) (\sum_{i \in [m]} (V_a^n \oplus I_a)) (\sum_{i \in [m]} V_a) \\
&= (\sum_{i \in [n+1]} \wedge_m^a) F(\varphi_{n+1,m}^s) (\sum_{i \in [m]} V_a^{n+1})
\end{aligned}$$

□

**Analysis of IP4.** Since IP4 holds when  $x \in \{a, b\}$  or  $y \in \{\alpha, \beta\}$  it remains to study four cases:  $c\gamma, c\delta, d\gamma, d\delta$ . By reduction c) the proof is reduced to the study of IP4 *in case*  $c\gamma$ .

**Lemma 2.21** *Condition IP4 in case  $c\gamma$  follows from axiom G.*

**Proof:** By induction on  $m$  we get

$$\begin{aligned}\wedge_{m+1}^a \cdot \vee_a^{m+1} &= \wedge^a \cdot (\wedge_m^a \oplus \mathbb{1}_a) \cdot (\vee_a^m \oplus \mathbb{1}_a) \cdot \vee_a \\ &= \wedge^a \cdot (\mathbb{1}_a \oplus \mathbb{1}_a) \cdot \vee_a \\ &= \mathbb{1}_a\end{aligned}$$

□

Using the above lemmas we get the following simple definitions for an  $xy$ -object.

**Corollary 2.22** *Let  $B$  be a ssmc. Then:*

- An  $a\beta$ -object is a pair  $(a, \top_a)$  with  $\top_a \in B(0, a)$ . A  $b\alpha$ -object is the dual concept.
- An  $a\gamma$ -object is a pair  $(a, \vee_a)$  with  $\vee_a \in B(a \oplus a, a)$  obeying axioms  $A$  and  $B$ . A  $c\alpha$ -object is the dual concept.
- An  $a\delta$ -object is a triple  $(a, \top_a, \vee_a)$  obeying axioms  $A$ ,  $B$  and  $C$ . A  $d\alpha$ -object is the dual concept.
- A  $b\beta$ -object is a triple  $(a, \top_a, \perp^a)$ , where  $\perp^a \in B(a, 0)$ , obeying axiom  $E$ . This concept is selfdual.
- A  $b\gamma$ -object is a triple  $(a, \vee_a, \perp^a)$  obeying axioms  $A$ ,  $B$  and  $D$ . A  $c\beta$ -object is the dual concept.
- A  $b\delta$ -object is a 4-uple  $(a, \top_a, \vee_a, \perp^a)$  obeying axioms  $A$ ,  $B$ ,  $C$ ,  $D$  and  $E$ . A  $d\beta$ -object is the dual concept.
- A  $c\gamma$ -object is a triple  $(a, \vee_a, \wedge^a)$ , where  $\wedge^a \in B(a, a \oplus a)$ , obeying axioms  $A$ ,  $B$ ,  $F$ ,  $G$ ,  $A^\circ$ , and  $B^\circ$ . This concept is selfdual.
- A  $c\delta$ -object is a 4-uple  $(a, \top_a, \vee_a, \wedge^a)$  obeying axioms  $A$ ,  $B$ ,  $C$ ,  $F$ ,  $G$ ,  $A^\circ$ ,  $B^\circ$ , and  $D^\circ$ . A  $d\gamma$ -object is the dual concept.
- A  $d\delta$ -object is a 5-uple  $(a, \top_a, \vee_a, \perp^a, \wedge^a)$  obeying all the axioms  $A$ ,  $B$ ,  $C$ ,  $D$ ,  $E$ ,  $F$ ,  $G$ ,  $A^\circ$ ,  $B^\circ$ ,  $C^\circ$ , and  $D^\circ$ . This concept is selfdual. □

## 2.6 Classes of relations $xy\text{-Rel}_S$ as enriched ssmc's

**Definition 2.23** ( $xy$ -ssmc)

Let  $B$  be a ssmc and  $xy$  be a restriction with  $x \in \{a, b, c, d\}$  and  $y \in \{\alpha, \beta, \gamma, \delta\}$ .

We say  $B$  is an  $xy$ -ssmc if every object in  $B$  is an  $xy$ -object and the corresponding axioms of type SV or  $SV^\circ$  in Table 2.1 hold.<sup>7</sup>

A morphism of  $xy$ -ssmc's  $H : B \rightarrow B'$  is a morphism of ssmc's that preserves the additional constants.<sup>8</sup> □

Let us note the coincidence of the notions of ssmc and  $a\alpha$ -ssmc. Clearly  $xy\text{-Rel}_S$  is an  $xy$ -ssmc. Finally, it is easy to see that the commuting conditions in the above definition of  $xy$ -ssmc are equivalent with the old ones, i.e.

<sup>7</sup>In detail, axioms SV1–SV2 have to be satisfied when  $y \in \{\beta, \delta\}$ , axioms SV3–SV4 when  $y \in \{\gamma, \delta\}$ , axioms SV1<sup>o</sup>–SV2<sup>o</sup> when  $x \in \{b, d\}$ , and axioms SV3<sup>o</sup>–SV4<sup>o</sup> when  $x \in \{c, d\}$ .

<sup>8</sup>That is, for every object  $a$  in  $B$ :

$$\begin{array}{ll} H(\top_a) = \top_{H(a)} & \text{when } y \in \{\beta, \delta\}; \\ H(\perp^a) = \perp^{H(a)} & \text{when } x \in \{b, d\}; \\ H(\vee_a) = \vee_{H(a)} & \text{when } y \in \{\gamma, \delta\}; \\ H(\wedge^a) = \wedge^{H(a)} & \text{when } x \in \{c, d\}. \end{array}$$

for every object  $a$  in  $B$ :

$$\begin{aligned} H(\wedge_m^a) &= \wedge_m^{H(a)} \quad \text{when } m \text{ obeys restriction } x \text{ and} \\ H(\vee_a^n) &= \vee_{H(a)}^n, \quad \text{when } n \text{ obeys restriction } y \end{aligned}$$

Now we may formulate the main result of this chapter.

**Theorem 2.24** *Let  $x \in \{a, b, c, d\}$  and  $y \in \{\alpha, \beta, \gamma, \delta\}$  be two restrictions.*

*If  $B$  is an  $xy$ -ssmc, then for every function  $h : S \rightarrow \mathcal{O}(B)$  there exists a unique morphism of  $xy$ -ssmc's*

$$H : xy\text{-}\mathbb{R}el_S \rightarrow B$$

*extending  $h$ , i.e., satisfying the condition  $H(s) = h(s)$ ,  $\forall s \in S$ .*

**Proof:** This theorem follows from Theorem 2.13. The only fact still open is the commutation with the constants  $\wedge^a$ ,  $\perp^a$ ,  $\vee_a$  and  $\top_a$  in the case  $a$  is an arbitrary word in  $S^*$ , not only a letter. This follows by an induction on the length of  $a$ . The case  $|a| = 0$  is trivial. The inductive step may be proved as follows: for  $a \in S^*$  and  $s \in S$

$$\begin{aligned} H(\wedge^{a \oplus s}) &= H((\wedge^a \oplus \wedge^s) \cdot (l_a \oplus {}^a\mathbf{X}^s \oplus l_s)) \\ &= (H(\wedge^a) \oplus H(\wedge^s)) \cdot (l_{h(a)} \oplus {}^{h(a)}\mathbf{X}^{h(s)} \oplus l_{h(s)}) \\ &= (\wedge^{h(a)} \oplus \wedge^{h(s)}) \cdot (l_{h(a)} \oplus {}^{h(a)}\mathbf{X}^{h(s)} \oplus l_{h(s)}) \\ &= \wedge^{h(a) \oplus h(s)} \\ &= \wedge^{h(a \oplus s)} \end{aligned}$$

where we have applied an axiom of type SV in order to infer the fourth equality.

For the other constants the proof is similar.  $\square$

Finally, let us note that Theorem 2.2 follows from this one in the following way. Denote by  $xy\text{-SSMC}_M$  the category of all  $xy$ -ssmc's having the monoid  $M$  as the monoid of the objects and whose morphisms are morphisms of  $xy$ -ssmc's which preserve the objects.

**Corollary 2.25** *For every  $x \in \{a, b, c, d\}$  and  $y \in \{\alpha, \beta, \gamma, \delta\}$  the algebra  $xy\text{-}\mathbb{R}el_S$  of  $S$ -sorted  $xy$ -relations is an initial object in the category  $xy\text{-SSMC}_{S^*}$ .  $\square$*

## 2.7 Short comments and references

The results of this chapter are based on [CaS91]. The presentation we have given follows the slightly improved version presented in Chapter A of [Ste91].

In [Laf92] a confluent and terminating rewriting system is given for  $a\delta$ -terms (functions).



# Chapter 3

## Critical acyclic structures (strong $xy$ -ssmc's)

In this chapter we introduce three critical structures that may be used to defined the behaviour of many-inputs/many-outputs objects.

- The first possibility is to use ordinary elements (single-input/single-output objects) and to describe the behaviour of a many-inputs/many-outputs object by a *matrix* of such elements. The resulting algebraic structure is called matrix theory.
- The second possibility is to use ranked elements (e.g., single-input/many-outputs objects) and to describe the behaviour of a many-inputs/many-outputs object by a *tuple* of such elements. The resulting algebraic structure is called algebraic theory.
- The last possibility is to represent such many-inputs/many-outputs objects as atoms of the calculus (doubly-ranked elements). This way we get ssmc's (symmetric strict monoidal categories) that already have been defined.

Matrix and algebraic theories are defined here as particular ssmc's, namely as ssmc's obeying additional strong commutation axioms.

### 3.1 Strong $xy$ -ssmc's

The set  $\{a, b, c, d\}$  is ordered by using the relation  $\prec_L$  given by  $a \prec_L b \prec_L d$ ,  $a \prec_L c \prec_L d$ ,  $\neg(b \prec_L c)$  and  $\neg(c \prec_L b)$ . In a similar way the relation  $\prec_G$  on the Greek letters  $\{\alpha, \beta, \gamma, \delta\}$  is defined.

**Definition 3.1** (strong  $xy$ -ssmc)

An  $xy$ -ssmc is  $x'y'$ -strong, for  $x' \prec_L x$  and  $y' \prec_G y$ , if all the strong axioms in Table 3.1 corresponding to the restrictions  $x'y'$  are fulfilled (i.e. axioms  $(C_{az}$ -mor) for  $z \prec_G y'$  and  $(C_{z\alpha}$ -mor) for  $z \prec_L x'$ ).

A *strong  $xy$ -ssmc* is an  $xy$ -ssmc which is  $xy$ -strong.  $\square$

For example, the definition of a  $c\gamma$ -strong  $c\delta$ -ssmc is obtained by adding the strong axioms corresponding to  $c\gamma$ , namely  $(C_{a\gamma}$ -mor) and  $(C_{c\alpha}$ -mor), to the axioms defining a  $c\delta$ -ssmc.

Table 3.1: The  $xy$ -strong axioms ( $f : a \rightarrow b$ ).

$(C_{a\beta}$ -mor)	$\top_a \cdot f = \top_b$	$(C_{b\beta}$ -mor)	$f \cdot \perp^b = \perp^a$
$(C_{a\gamma}$ -mor)	$\vee_a \cdot f = (f \oplus f) \cdot \vee_b$	$(C_{c\alpha}$ -mor)	$f \cdot \wedge^b = \wedge^a \cdot (f \oplus f)$

The axioms in Table 3.1 are strong in the following sense: in an arbitrary  $xy$ -ssmc only the restriction of the  $xy$ -strong axioms to the case when  $f$  is an  $xy$ -morphism (ground term) is required. They are axioms of commutation of the composition of a constant in  $\top$ ,  $\vee$ ,  $\perp$ , or  $\wedge$  with an arbitrary morphism in the underlined category. Note that the axioms B6 and B8–B9 in the definition of a ssmc are of the same type showing the commutation of the constants  $\perp_a$  and  ${}^a\mathbf{X}^b$  with arbitrary morphisms.

**Proposition 3.2** (*commutation of  $xy$ -morphisms with arbitrary morphisms*)

Let  $B$  be a strong  $xy$ -ssmc,  $\varphi$  an  $xy$ -relation in  $xy\text{-}\mathbb{R}el_S(a, b)$ , and  $i, o : xy\text{-}\mathbb{R}el_S \rightarrow B$  two morphisms of  $xy$ -ssmc's.

If  $f_j \in B(i(a_j), o(a_j))$ , for  $j \in [|a|]$ , and  $g_k \in B(i(b_k), o(b_k))$ , for  $k \in [|b|]$ , are such that  $f_j = g_k$  whenever  $(j, k) \in \varphi$ , then

$$(f_1 \oplus \dots \oplus f_{|a|}) \cdot o(\varphi) = i(\varphi) \cdot (g_1 \oplus \dots \oplus g_{|b|})$$

**Proof:** Denote by  $Z \subseteq xy\text{-}\mathbb{R}el_S$  the substructure given by those  $\phi$  which obey the property in the statement of the proposition for all  $f_j, g_k$ . Since  $B$  is  $xy$ -strong all the constants in  $\top_a, \vee_a, \perp^a, \wedge^a$  which have  $xy$ -type are included in  $Z$ . In addition,  $Z$  is closed under summation and composition, hence it is equal to  $xy\text{-}\mathbb{R}el_S$ .

Below we give some details for the closure to composition (the closure to summation is fairly easy). Let  $\phi \in xy\text{-}\mathbb{R}el_S(a, b)$  be of the form  $\phi = \sigma \cdot \tau$  with  $\sigma \in Z(a, c)$  and  $\tau \in Z(c, b)$ . If  $f_j$  for  $j \in [|a|]$  and  $g_k$  for  $k \in [|b|]$  are as in the statement of the proposition, then let us consider some morphisms  $h_l \in B(i(c_l), o(c_l))$  for  $l \in [|c|]$  defined by

$$h_l = \begin{cases} f_j & \text{if } (j, l) \in \sigma \\ g_k & \text{if } (l, k) \in \tau \\ \text{arbitrary} & \text{otherwise} \end{cases}$$

As  $f_j = g_k$  whenever  $(i, j) \in \phi$  it follows that the above definition is correct. As  $\sigma$  and  $\tau$  are in  $Z$  we have

$$(f_1 \oplus \dots \oplus f_{|a|}) \cdot o(\sigma) = i(\sigma) \cdot (h_1 \oplus \dots \oplus h_{|c|})$$

and

$$(h_1 \oplus \dots \oplus h_{|c|}) \cdot o(\tau) = i(\tau) \cdot (g_1 \oplus \dots \oplus g_{|b|})$$

These identities clearly implies

$$(f_1 \oplus \dots \oplus f_{|a|}) \cdot o(\phi) = i(\phi) \cdot (g_1 \oplus \dots \oplus g_{|b|})$$

hence  $\phi \in Z$ .  $\square$

In the particular case when  $xy = a\alpha$  this proposition coincides with Proposition 2.7, while in the case  $\varphi$  is one constant of type  $\top, \vee, \perp$ , or  $\wedge$  the identity in the statement of this proposition coincides with the corresponding identity in Table 3.1.

## 3.2 Algebraic theories ( $a\delta$ -strong ssmc's)

**Definition 3.3** (algebraic theory)

An *algebraic theory* is a strong  $a\delta$ -ssmc.  $\square$

It is easy to see that this definition of the algebraic theories coincides with the classical one in [Law63, Elg75], etc. For us the implication given in Proposition 3.4 below is important showing that every morphism with multiple inputs is a tuple of morphisms with single input.

**Proposition 3.4** *Let  $B$  be a strong  $a\delta$ -ssmc. For every morphism  $f \in B(a \oplus b, c)$  there exists a unique pair  $f_1 \in B(a, c)$  and  $f_2 \in B(b, c)$  such that<sup>1</sup>*

$$f = (f_1 \oplus f_2) \cdot \vee_c$$

**Proof:** For  $f \in B(a \oplus b, c)$  let us denote  $f_1 = (l_a \oplus \top_b) \cdot f$  and  $f_2 = (\top_a \oplus l_b) \cdot f$ . Then obviously,

$$\begin{aligned} (f_1 \oplus f_2) \cdot \vee_c &= [(l_a \oplus \top_b)f \oplus (\top_a \oplus l_b) \cdot f] \cdot \vee_c && \text{definition} \\ &= (l_a \oplus \top_b \oplus \top_a \oplus l_b) \cdot (f \oplus f) \cdot \vee_c \\ &= (l_a \oplus \top_b \oplus \top_a \oplus l_b) \cdot \vee_{a \oplus b} \cdot f && (C_{a\gamma}\text{-mor}) \\ &= f \end{aligned}$$

If  $g_1 \in B(a, c)$  and  $g_2 \in B(b, c)$  are morphisms obeying condition  $f = (g_1 \oplus g_2) \cdot \vee_c$ , then

$$\begin{aligned} f_1 &= (l_a \oplus \top_b) \cdot f \\ &= (l_a \oplus \top_b) \cdot (g_1 \oplus g_2) \cdot \vee_c && \text{hypothesis} \\ &= (g_1 \oplus \top_c) \cdot \vee_c && (C_{a\beta}\text{-mor}) \\ &= g_1 \cdot (l_c \oplus \top_c) \cdot \vee_c \\ &= g_1 \end{aligned}$$

and in a similar way one may prove that  $f_2 = g_2$ . That is, the pair is unique.  $\square$

## 3.3 Matrix theories ( $a\delta$ - and $d\alpha$ -strong ssmc's)

**Definition 3.5** (matrix theory)

A *matrix theory* is a ssmc which simultaneously is  $a\delta$ -strong and  $d\alpha$ -strong.  $\square$

Since the axioms D, D<sup>o</sup>, E and F follow from the axioms ( $C_{a\gamma}$ -mor), ( $C_{a\beta}$ -mor), ( $C_{b\alpha}$ -mor), and ( $C_{c\alpha}$ -mor) one gets that all the axioms in Table 2.1 are valid with one possible exception only: axiom G.

It is easy to see that this definition coincides with the classical one, an implication following from the Proposition 3.6, below.

---

<sup>1</sup>In this context  $f$  is called the *tupling* of the morphisms  $f_1$  and  $f_2$ . The standard notation used for tupling is  $f = \langle f_1, f_2 \rangle$ .

**Proposition 3.6** *Let  $B$  be a ssms that is simultaneous a strong  $a\delta$ -ssmc and a strong  $d\alpha$ -ssmc. Then for every morphism  $f \in B(a \oplus b, c \oplus d)$  there exists a unique 4-uple of morphisms  $f_{11} \in B(a, c)$ ,  $f_{12} \in B(a, d)$ ,  $f_{21} \in B(b, c)$ , and  $f_{22} \in B(b, d)$  such that*

$$[\wedge^a \cdot (f_{11} \oplus f_{12}) \oplus \wedge^b \cdot (f_{21} \oplus f_{22})] \cdot \vee_{c \oplus d} = f.$$

*The morphism in the left hand side of the above equality is equal to the morphism  $\wedge^{a \oplus b} \cdot [(f_{11} \oplus f_{21}) \cdot \vee_c \oplus (f_{12} \oplus f_{22}) \cdot \vee_d]$  and it is denoted simply as a matrix*

$$\begin{pmatrix} f_{11} & f_{12} \\ f_{21} & f_{22} \end{pmatrix}$$

**Proof:** For an  $f \in B(a \oplus b, c \oplus d)$  by the Proposition 3.4 there is a unique pair  $\langle f_1, f_2 \rangle$  with  $f_1 \in B(a, c \oplus d)$ ,  $f_2 \in B(b, c \oplus d)$  such that

$$(f_1 \oplus f_2) \cdot \vee_{c \oplus d} = f$$

By using the dual of Proposition 3.4 for  $f_1$  (resp.  $f_2$ ) we get a unique pair  $\langle f_{11}, f_{12} \rangle$  with  $f_{11} \in B(a, c)$ ,  $f_{12} \in B(a, d)$  (resp.  $\langle f_{21}, f_{22} \rangle$  with  $f_{21} \in B(b, c)$ ,  $f_{22} \in B(b, d)$ ) such that

$$f_1 = \wedge^a \cdot (f_{11} \oplus f_{12}) \quad (\text{resp. } f_2 = \wedge^b \cdot (f_{21} \oplus f_{22}))$$

So we get the required identity.

For the uniqueness, if for  $i, j \in [2]$ ,  $g_{ij}$  satisfies the identity and have the same sources and targets as the morphisms  $f_{ij}$  defined above, then from the uniqueness given by Proposition 3.4 it follows that  $\wedge^a \cdot (g_{11} \oplus g_{12}) = f_1$  and  $\wedge^b \cdot (g_{21} \oplus g_{22}) = f_2$ . Next, we apply the uniqueness given by the dual of Proposition 3.4. Hence,  $g_{11} = f_{11}$  and  $g_{12} = f_{12}$  (resp.  $g_{21} = f_{21}$  and  $g_{22} = f_{22}$ ).

Finally, the equality of both expressions that define  $\begin{pmatrix} f_{11} & f_{12} \\ f_{21} & f_{22} \end{pmatrix}$  follows by permuting (with B10) the middle terms  $f_{12}$  and  $f_{21}$  and applying axioms  $SV4$  and  $SV4^o$ .  $\square$

We may display the form of the components of the matrix associated to a morphism  $f \in B(a \oplus b, c \oplus d)$ , namely

$$f = \begin{pmatrix} (l_a \oplus \top_b) \cdot f \cdot (l_c \oplus \perp^d) & (l_a \oplus \top_b) \cdot f \cdot (\perp^c \oplus l_d) \\ (\top_a \oplus l_b) \cdot f \cdot (l_c \oplus \perp^d) & (\top_a \oplus l_b) \cdot f \cdot (\perp^c \oplus l_d) \end{pmatrix}.$$

We mention here the following result (see [Elg76a]). Let  $B$  be a matrix theory over  $(\mathbb{N}, +, 0)$ . On the set  $B(1, 1)$  we introduce the operations

$$f \cup g = \wedge^1 \cdot (f \oplus g) \cdot \vee_1; \quad f \cdot g = f \cdot g; \quad 0 = \perp^1 \cdot \top_1; \quad \text{and } 1 = l_1.$$

So we get a semiring  $(B(1, 1), \cup, \cdot, 0, 1)$ . Conversely, given a semiring  $S$  the usual matrices with elements in  $S$  may be structured as a matrix theory in Elgot's sense. Since our definition for a matrix theory differs from that of Elgot we give some details here.

**Definition 3.7** (semiring)

A *semiring*  $S = (S, \cup, \cdot, 0, 1)$  is a set  $S$  endowed with two binary operations  $\cup, \cdot$  and constants  $0, 1$  such that:  $(S, \cup, 0)$  is a commutative monoid,  $(S, \cdot, 1)$  is a monoid, and the distributive laws

$$\begin{aligned} a \cdot (b \cup c) &= (a \cdot b) \cup (a \cdot c), \\ (a \cup b) \cdot c &= (a \cdot c) \cup (b \cdot c) \end{aligned}$$

and the zero law

$$0 \cdot a = 0 = a \cdot 0$$

hold for every  $a, b, c \in S$ .

A semiring is called *idempotent* if  $a \cup a = a$  for every  $a \in S$ .  $\square$

An easy computation shows that the above structure  $\mathcal{S}(B) = (B(1, 1), \cup, \cdot, 0, 1)$  is a semiring whenever  $B$  is a matrix theory. For example, one may prove the left distributivity law as follows:

$$\begin{aligned} f \cap (g \cup h) &= f \cdot [\wedge^1 \cdot (g \oplus h) \cdot \vee_1] \\ &= \wedge^1 \cdot (f \oplus f) \cdot (g \oplus h) \cdot \vee_1 && (\text{C}_{ca}\text{-mor}) \\ &= \wedge^1 \cdot (f \cdot g \oplus f \cdot h) \cdot \vee_1 \\ &= (f \cap g) \cup (f \cap h) \end{aligned}$$

Conversely, if  $(S, \cup, \cdot, 0, 1)$  is a semiring, then one may construct the theory  $\mathcal{M}(S)$  of matrices over  $S$  in the usual way: <sup>2</sup>

$$\mathcal{M}(S)(m, n) = \{A : A \text{ is an } m \times n \text{ matrix with entries in } S\}, \quad \text{for } m, n \geq 0.$$

In  $\mathcal{M}(S)$  the following operations and constants may be introduced:

- $A \cdot B =$  “the usual product of the matrices  $A$  and  $B$  ”,
- $A \oplus B = \begin{pmatrix} A & 0 \\ 0 & B \end{pmatrix}$ ,  $l_n = \begin{pmatrix} 1 & \dots & 0 \\ \vdots & \ddots & \vdots \\ 0 & \dots & 1 \end{pmatrix}$ ,  $m \times n = \begin{pmatrix} 0 & l_m \\ l_n & 0 \end{pmatrix}$ ,  $\vee_n = \begin{pmatrix} l_n \\ l_n \end{pmatrix}$ ,
- $\wedge^n = (l_n \ l_n)$ ,  $\top_n =$  “the unique element in  $\mathcal{M}(S)(0, n)$  ”,
- $\perp_n =$  “the unique element in  $\mathcal{M}(S)(n, 0)$  ”.

An easy computation shows that the transformations  $\mathcal{M}$  and  $\mathcal{S}$  are inverses one to the other. Consequently,

**Proposition 3.8** *The notion of a matrix theory over  $(\mathbb{N}, +, 0)$  coincides with that of a theory of matrices over a semiring.  $\square$*

From this result it follows that a strong  $d\delta$ -ssms (actually being a matrix theory satisfying axiom G) is equivalent with the theory of matrices over an idempotent semiring.

---

<sup>2</sup>In the case  $m = 0$  by convention  $\mathcal{M}(S)(m, n)$  has a unique element, namely the “matrix” with 0 rows and  $n$  columns; similarly for  $n = 0$ .

### 3.4 Short comments and references

Matrix theories are classical structures. (See [Elg76b] for their relationship with algebraic theories.)

Algebraic theories are introduced in [Law63] and widely used in the study of the semantic of programs, e.g. in [Elg75, Elg76a, WTWG76, GTWR77, ElBT78, ArM80, Man92, BIEs93a].

The term symmetric strict monoidal category is used in [MacL71]. Similar structures, called  $x$ -categories were used by Hotz, see [Hot65, Mol88].

In the field of flowchart theories ssms'c are used in [ELS82, Ste86, Bar87a, CaS88a, CaS90a].

In logic ssmc's are used in the study of the algebra of proofs in [Sza80]. The passage from matrix theories to ssmc's corresponds to the passage from classical logic to linear logic, step made in [Gir87]. A lot of works on linear logic use these structures.

Ssmc's appears in other algebraic studies related to various kind of nets, e.g. in [Mol88, MeM90].

**Part II**

**Algebra of Cyclic Flowgraphs**

# Chapter 4

## Flowgraphs and $a\alpha$ -flownomials

In this chapter we present the  $a\alpha$ -version of the calculus of flownomials. This calculus is very similar with the classical calculus of polynomials and gives an algebraisation for flowgraphs (= labeled directed hypergraphs). More precisely the usual flowgraphs may be identified with  $a\alpha$ -flownomials which use a particular class of finite binary relations for connecting the variables (= atomic blocks).

The entity corresponding to integer number is the finite binary relation. After a reconsideration of these relations in a context where a new operation on relations is used (i.e. feedback) we shall introduce flownomial expressions and  $a\alpha$ -Flow-Calculus.

The main result asserts that  $a\alpha$ -Flow-Calculus is a mathematical model for flowgraphs, more precisely it is shown that all flowgraphs may be represented by flownomial expressions built up with a proper class of connecting relations and the rules of  $a\alpha$ -Flow-Calculus are correct and complete with respect to the property of flownomial expressions to represent the same flowgraph. The proof of this result will be given in the next chapter in an abstract setting.

### 4.1 Short presentation of relations with feedback

We recall some definitions. Let  $S$  be a sort set. The elements in the free monoid  $S^*$  are denoted by  $a = a_1 \oplus \dots \oplus a_{|a|}$ , where  $|a|$  is the length of the word  $a$  and  $a_i \in S$ , for all  $i \in [|a|]$ .

$\mathbb{R}el_S$  is the theory of finite  $S$ -sorted binary relations, namely that given by the family of the sets

$$\mathbb{R}el_S(a, b) = \{r \subseteq [|a|] \times [|b|] : (i, j) \in r \Rightarrow a_i = b_j\}, \quad \text{for } a, b \in S^*.$$

The operations of summation and composition were defined in Chapter 2.1.c). The new operation used here is:

- **FEEDBACK**  $\uparrow^s$ :  $\mathbb{R}el_S(a \oplus s, b \oplus s) \rightarrow \mathbb{R}el_S(a, b)$ , for  $a, b \in S^*$  and  $s \in S$  given by

$$\begin{aligned} r \uparrow^s &= \{(i, j) : i \in [|a|], j \in [|b|] \text{ and } (i, j) \in r\} \\ &\cup \{(i, j) : i \in [|a|], j \in [|b|], (i, |b| + 1) \in r \text{ and } (|a| + 1, j) \in r\} \end{aligned}$$

We recall that beside these basic operations we are using six types of constants denoted by  $\mathbb{1}_a$ ,  ${}^a\mathbf{X}^b$ ,  $\vee_a$ ,  $\top_a$ ,  $\wedge^a$  and  $\perp^a$  whose meaning in  $\mathbb{R}el$  is the following:



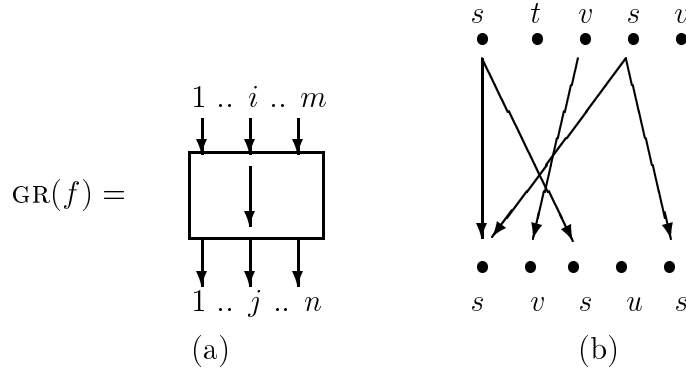

Figure 4.1: The generic representation of a relation (a) and an concrete example (b)

$$l_a = \{(i, i) : i \in [|a|]\} \in \mathbb{R}el(a, a)$$

$${}^aX^b = \{(i, |a| + i) : i \in [|a|]\} \cup \{(|a| + i, i) : i \in [|b|]\} \in \mathbb{R}el(a \oplus b, b \oplus a)$$

$$\vee_a = \{(i, i) : i \in [|a|]\} \cup \{(|a| + i, i) : i \in [|a|]\} \in \mathbb{R}el(a \oplus a, a)$$

$$\top_a = \emptyset \in \mathbb{R}el(0, a)$$

$$\wedge^a = \{(i, i) : i \in [|a|]\} \cup \{(i, |a| + i) : i \in [|a|]\} \in \mathbb{R}el(a, a \oplus a)$$

$$\perp^a = \emptyset \in \mathbb{R}el(a, 0)$$

**Example 4.1** We graphically represent a relation by using arrows going from up to bottom. A relation  $f \in \mathbb{R}el(m, n)$  is represented as in Figure 4.1.(a). For instance, the picture corresponding to the relation  $\{(1, 1), (1, 3), (3, 2), (4, 1), (4, 5)\} \in \mathbb{R}el_{\{s,t,u,v\}}(s \oplus t \oplus v \oplus s \oplus v, s \oplus v \oplus s \oplus u \oplus s)$  is give in Figure 4.1.(b). Moreover, the symbols  $l_a$ ,  ${}^aX^b$ ,  $\top_a$ ,  $\vee_a$ ,  $\wedge^a$ ,  $\perp^a$  has been chosen in such a way to suggest this pictural representation. For example, in the omogen (one-sorted) case the constants may be graphically represented as follows.

$$l_1 = \downarrow, \quad {}^1X^1 = \begin{array}{c} \times \\ \downarrow \end{array}, \quad \vee_1 = \begin{array}{c} \vee \\ \downarrow \end{array}, \quad \top_1 = \begin{array}{c} \vdots \\ \downarrow \\ \vdots \end{array}, \quad \wedge^1 = \begin{array}{c} \wedge \\ \downarrow \end{array}, \quad \text{and } \perp^1 = \begin{array}{c} \downarrow \\ \vdots \end{array}.$$

If in such a constant a number  $n$  (or  $m$ ) grater than 1 appears, then the corresponding arrow is replaced by a compact group of  $n$  (resp.  $m$ ) parallel arrows. For example,

$${}^1X^2 = \begin{array}{c} \downarrow \downarrow \\ \times \\ \downarrow \downarrow \end{array}, \quad \vee_2 = \begin{array}{c} \vee \\ \downarrow \downarrow \end{array}, \quad \perp^3 = \begin{array}{c} \vdots \\ \downarrow \downarrow \downarrow \\ \vdots \end{array}.$$

Figure 4.2 illustrates how the operations act on relations.  $\square$

From the aforementioned subtheories of  $\mathbb{R}el$  the theories  $\mathbb{I}Bi$ ,  $\mathbb{I}In$ ,  $\mathbb{I}PSur$ , and  $\mathbb{I}Pfn$  are closed with respect to all the operations summation, composition and feedback, while the theories  $\mathbb{S}Sur$  and  $\mathbb{I}Fn$  are closed only with respect to summation and composition. The last (lower-right) example in Figure 4.2 shows that  $\mathbb{S}Sur$  and  $\mathbb{I}Fn$  are not closed with respect to feedback.

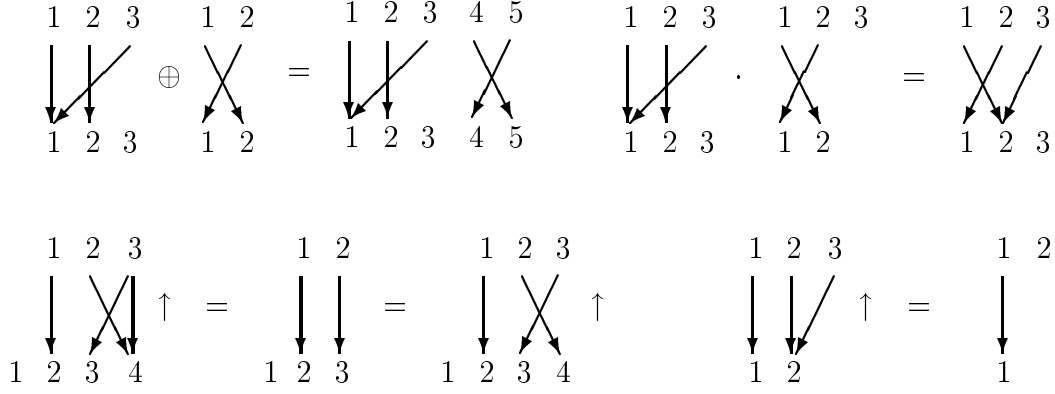

Figure 4.2: Operations on relations

---

## 4.2 Flonomial expressions; $a\alpha$ -Flow-Calculus

### 4.2.1 Defining flonomial expressions and $a\alpha$ -Flow-Calculus.

We have defined operations and constants on relations. In order to construct the calculus with flonomials we still need a family  $X$  of sets of doubly-ranked variables  $X = \{X(a, b)\}_{a, b \in S^*}$ . An element  $x \in X(a, b)$  is considered as a variable atom with  $|a|$  entries of sorts  $a_1, \dots, a_{|a|}$  and  $|b|$  exits of sorts  $b_1, \dots, b_{|b|}$ .

**Definition 4.2** (flonomial expressions over  $\mathbb{R}\text{el}_S$ )

For  $a, b \in S^*$ , the sets  $\mathbb{F}\ell_{EXP}[X, \mathbb{R}\text{el}_S](a, b)$  of *flonomial expressions of type  $a \rightarrow b$  over  $X$  and  $\mathbb{R}\text{el}_S$*  are defined as follows:

- (i) the variables  $x \in X(a, b)$  and the symbols denoting relations  $f \in \mathbb{R}\text{el}_S(a, b)$  are atomic expressions of type  $a \rightarrow b$ ;
- (ii) compound expressions: if  $E^1 : a \rightarrow b$ ,  $E^2 : c \rightarrow d$ ,  $E^3 : b \rightarrow c$  and  $E : a \oplus s \rightarrow b \oplus s$ , ( $a, b, c \in S^*$ ,  $s \in S$ ) are flonomial expressions of the indicated type, then

$$(E^1 \oplus E^2) : a \oplus c \rightarrow b \oplus d$$

$$(E^1 \cdot E^3) : a \rightarrow c$$

$$(E \uparrow^s) : a \rightarrow b$$

are flonomial expressions of the indicated type;

- (iii) all the flonomial expressions are obtained by using rules (i) and (ii).

□

First a comment: Sometimes it is necessary to distinguish between an expression  $f$  in  $\mathbb{F}\ell_{EXP}[X, \mathbb{R}\text{el}]$  and the corresponding relation  $f$  in  $\mathbb{R}\text{el}$ . In such a case we denote by  $n(f)$  the expression corresponding to the relation  $f$ .

Table 4.1: The rules for  $a\alpha$ -Flow-Calculus (over  $T$ )

R0 $_T$	subexpressions involving only elements in $T$ are replaced by the corresponding values computed in $T$	
R1	$f \oplus (g \oplus h) = (f \oplus g) \oplus h$	(“ $\oplus$ ” is associative)
R2	$l_0 \oplus f = f = f \oplus l_0$	( $l_0$ is neutral element for “ $\oplus$ ”)
R3	$f \cdot (g \cdot h) = (f \cdot g) \cdot h$	(“ $\cdot$ ” is associative)
R4	$l_a \cdot f = f = f \cdot l_b$	( $l_a, l_b$ are neutral elements for “ $\cdot$ ”)
R5	$(f \oplus f') \cdot (g \oplus g') = (f \cdot g) \oplus (f' \cdot g')$ for $a \xrightarrow{f} b \xrightarrow{g} c, a' \xrightarrow{f'} b' \xrightarrow{g'} c'$	(relating “ $\cdot$ ” and “ $\oplus$ ”)
R6	$f \oplus g = {}^a\mathbf{X}^b \cdot (g \oplus f) \cdot {}^d\mathbf{X}^c$ for $f : a \rightarrow c, g : b \rightarrow d$	(“ $\oplus$ ” is “commutative”)
R7	$f \cdot (g \uparrow^c) \cdot h = ((f \oplus l_c) \cdot g \cdot (h \oplus l_c)) \uparrow^c$	(relating “ $\uparrow$ ” and “ $\cdot$ ”)
R8	$f \oplus (g \uparrow^c) = (f \oplus g) \uparrow^c$	(relating “ $\uparrow$ ” and “ $\oplus$ ”)
R9	$(f \cdot (l_b \oplus g)) \uparrow^c = ((l_a \oplus g) \cdot f) \uparrow^d$ for $f : a \oplus c \rightarrow b \oplus d, g : d \rightarrow c$	(shifting blocks on feedback)
EqL	equational reasoning	

In what follows we shall omit many parentheses in flownomial expressions by declaring that: feedback has the strongest binding power, then composition, then summation; summation and composition are supposed to be associative. Thus for example,

$$((x \oplus x) \oplus ((x \oplus y) \cdot ((f \uparrow^s) \uparrow^t))) \quad \text{is written} \quad x \oplus x \oplus (x \oplus y) f \uparrow^{t \oplus s}.$$

This also illustrates that  $\uparrow^a$  means  $\uparrow^{a|a|} \dots \uparrow^{a1}$  and  $\cdot$  may be omitted.

The flownomial expressions over  $\mathbb{R}el$  are subject of the identities R0 $_{\mathbb{R}el}$ +R1–R9+EqL in Table 4.1. The basic rules for the resulted  $a\alpha$ -Flow-Calculus are R1–R9. Since they use only the constants  $l_a$  and  ${}^a\mathbf{X}^b$ , the rule R0 makes sense not only for  $T = \mathbb{R}el$ , but also for an arbitrary subtheory  $T \subseteq \mathbb{R}el$  which contains these constants and is closed with respect to the operations. For instance,  $a\alpha$ -Flow-Calculus may be done also over  $\mathbb{B}i$ ,  $\mathbb{I}n$ ,  $\mathbb{P}Sur$ , or  $\mathbb{P}fn$ .

**Definition 4.3** ( $a\alpha$ -Flow-Calculus,  $a\alpha$ -flownomials)

The  $a\alpha$ -Flow-Calculus is given by the rules R0 $_{\mathbb{R}el}$ +R1–R9+EqL in Table 4.1.

An  $a\alpha$ -flownomial over  $X$  and  $T$  is a  $\sim_{a\alpha}$ -congruence class, where  $\sim_{a\alpha}$  is the congruence relation generated on  $\mathbb{F}\ell_{EXP}[X, T]$  by the rules R0 $_T$  and R1–R9, or equivalently, the transitive relation generated by the rules R0 $_T$ +R1–R9+EqL.

(Note that, in fact,  $\sim_{a\alpha}$  consists of a family of equivalence relations  $\sim_{a\alpha}^{a,b}$  on  $\mathbb{F}\ell_{EXP}[X, T](a, b)$ , for  $a, b \in S^*$ .)  $\square$

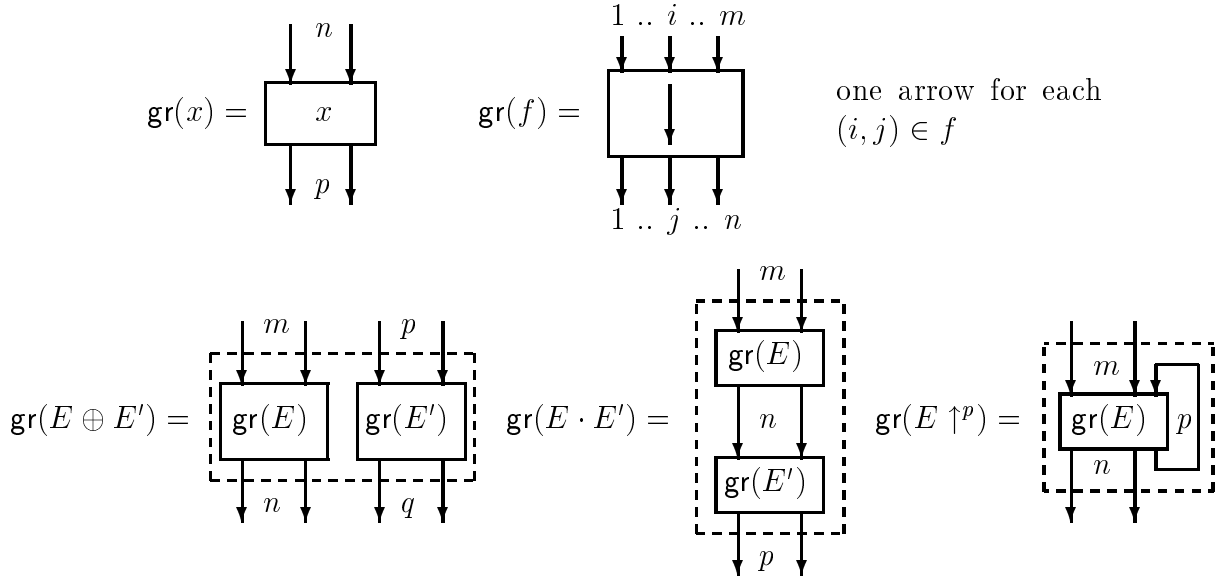

Figure 4.3: The graphical interpretation of flownomial expressions

## 4.2.2 Graphical interpretation

Every flownomial expression  $f$  in  $\mathbb{F}\ell_{EXP}[X, T]$ , for  $T \subseteq \mathbb{R}el$  may be graphically interpreted as a graph  $gr(f)$  using the rules in the Figure 4.3. Again we use the one-sorted case. The reader should have no problems to deal with many-sorted flowgraphs; — just be careful, the channels that are connected by composition or feedback be of the same type.

The rules of  $a\alpha$ -Flow-Calculus may be illustrated as in Figure 4.4.

## 4.2.3 The meaning of $a\alpha$ -Flow-Calculus

We claim that the  $a\alpha$ -Flow-Calculus is a calculus for flowgraphs, i.e these flowgraphs may be identified with  $a\alpha$ -flownomials. The claim is based on two facts.

**Fact 4.4** (*fitness of the operations*)

The nondeterministic (resp. partial deterministic) flowgraphs built up with atoms in  $X$  coincides with the graphical representations of expressions  $E$  in  $\mathbb{F}\ell_{EXP}[X, \mathbb{R}el]$  (resp. in  $\mathbb{F}\ell_{EXP}[X, \mathbb{P}fn]$ ).

**Fact 4.5** (*fitness of the rules R0-R9*)

Let  $T \subseteq \mathbb{R}el$  be closed with respect to the operations, for example  $T = \mathbb{P}fn$ , or  $T = \mathbb{R}el$ .

- (i) (*correctness*) Two flownomial expressions over  $T$  which are equivalent via the rules  $R0_T + R1 - R9 + EqL$  have isomorphic graphical representations.
- (ii) (*completeness*) Two flownomial expressions over  $T$  which have isomorphic graphical representations may be proved equivalent using the rules  $R0_T + R1 - R9 + EqL$ .

□

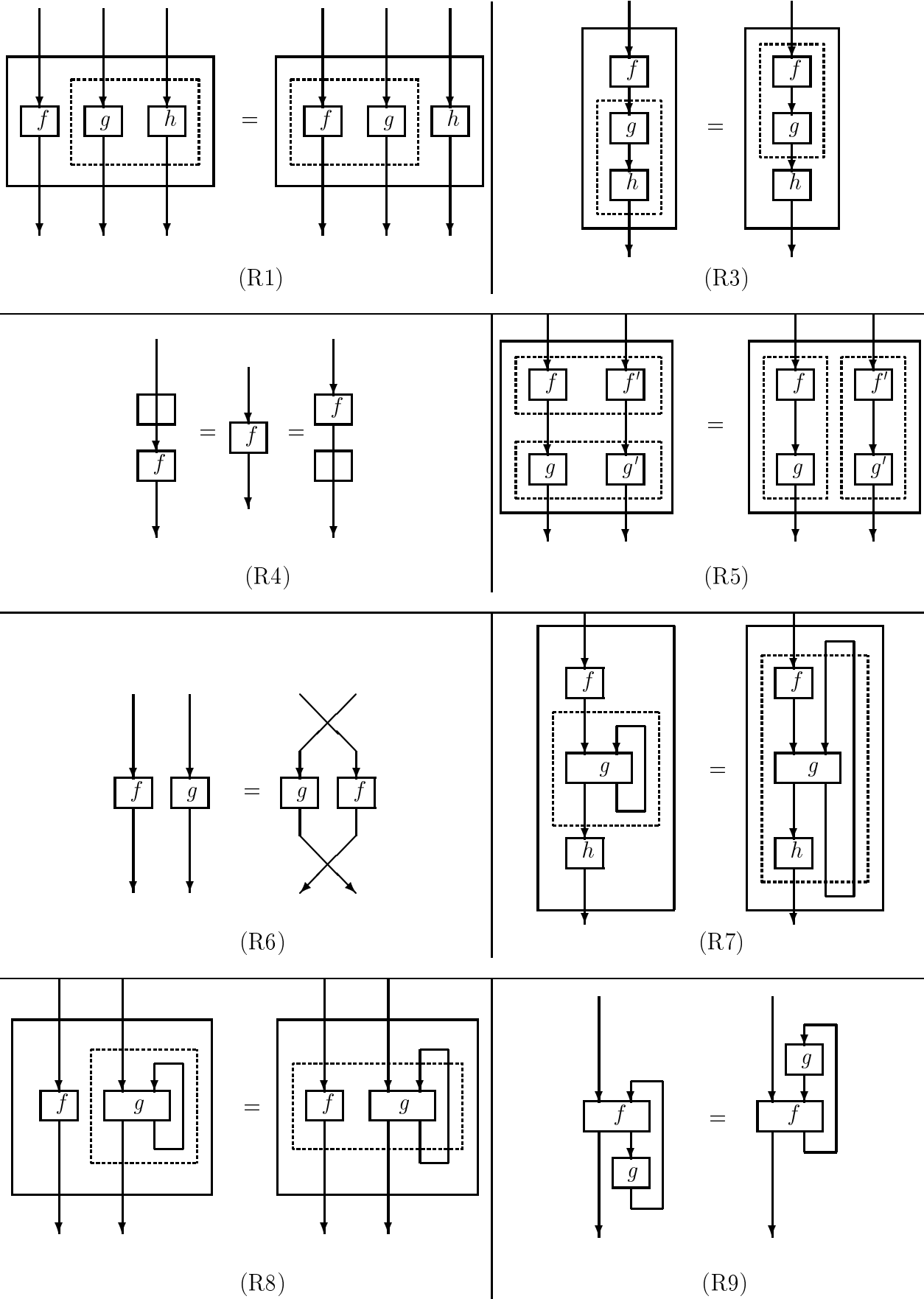

Figure 4.4: Graphical representation of rules R1–R9

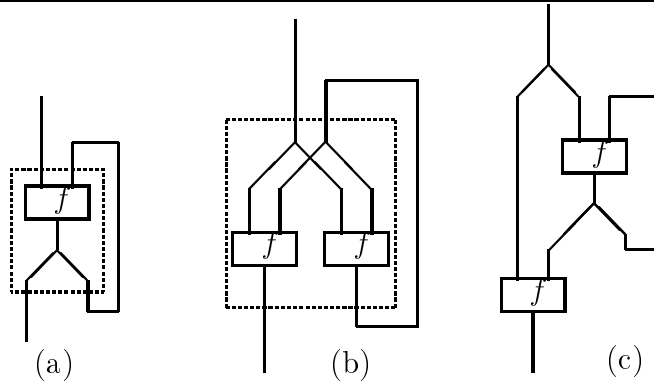

Figure 4.5: Graph isomorphism  $+ f \cdot \wedge^b = \wedge^a \cdot (f \oplus f) \Rightarrow$  fixed-point equation

Using pictures one may easily check that the correctness part holds. But for the completeness part, as well as for the first theorem, we need the whole machinery of the normal form representations.<sup>1</sup> The proofs of these results will be given in the next chapter in a more general, abstract setting.

#### 4.2.4 Example

**Example 4.6** Below we we prove that two expressions associated to the flowgraphs in Figure 4.5 (b) and (c) are equivalent using the rules of  $a\alpha$ -Flow-Calculus:

$$\begin{aligned}
[\wedge_2^{b \oplus a} \cdot (f \oplus f)] \uparrow^a &= [(\wedge_2^b \oplus \wedge_2^a) \cdot (l_b \oplus {}^b X^a \oplus l_a) \cdot (l_{b \oplus a} \oplus f) \cdot (f \oplus l_a)] \uparrow^a && \text{R0}_{\text{Rel}}, \text{R4}, \text{R5} \\
&= \wedge_2^b \cdot (l_{b \oplus b} \oplus \wedge_2^a) \cdot (l_b \oplus {}^b X^a \oplus l_a) \cdot (l_{b \oplus a} \oplus f)] \uparrow^a \cdot f && \text{R7} \\
&= \wedge_2^b \cdot [(l_b \oplus {}^b X^a \oplus l_a) \cdot (l_{b \oplus a} \oplus f) \cdot (l_{b \oplus a} \oplus \wedge_2^a)] \uparrow^{a \oplus a} \cdot f && \text{R9} \\
&= \wedge_2^b \cdot [(l_b \oplus {}^b X^a \oplus l_a) \cdot (l_{b \oplus a} \oplus f) \cdot (l_{b \oplus a} \oplus \wedge_2^a)] \uparrow^a \uparrow^a \cdot f \\
&= \wedge_2^b \cdot [(l_b \oplus {}^b X^a) \cdot (l_{b \oplus a} \oplus f \cdot \wedge_2^a) \uparrow^a] \uparrow^a \cdot f && \text{R7} \\
&= \wedge_2^b \cdot [(l_b \oplus {}^b X^a) \cdot (l_b \oplus l_a \oplus (f \cdot \wedge_2^a) \uparrow^a)] \uparrow^a \cdot f && \text{R8} \\
&= \wedge_2^b \cdot (l_b \oplus [(f \cdot \wedge_2^a) \uparrow^a \oplus l_a] \cdot {}^a X^a) \uparrow^a \cdot f && \text{R5, R6} \\
&= \wedge_2^b \cdot [l_b \oplus (f \cdot \wedge_2^a) \uparrow^a] \cdot (l_b \oplus ({}^a X^a) \uparrow^a) \cdot f && \text{R7, R8} \\
&= \wedge_2^b \cdot (l_b \oplus (f \cdot \wedge_2^a) \uparrow^a) \cdot f && \text{R0}_{\text{Rel}}
\end{aligned}$$

□

### 4.3 Flownomial expressions over abstract connecting theories

It is well-known that the natural numbers used to build certain polynomials are not enough to study such polynomials and are extended to integer, rational, real or complex numbers.

<sup>1</sup>A flownomial expression is in a *normal form* if it is written as  $((l_a \oplus x_1 \oplus \dots \oplus x_k) \cdot f) \uparrow^r$  where  $r = a_1 \oplus \dots \oplus a_k$ ,  $x_1 \in X(a_1, b_1), \dots, x_k \in X(a_k, b_k)$  and  $f \in T(a \oplus b_1 \oplus \dots \oplus b_k, b \oplus a_1 \oplus \dots \oplus a_k)$ . (See below)

In the same way the finite binary relations used to construct certain flownomials are not enough to study such flownomials, which denote programs.

For example, one may interpret some variables using a particular semantic domain. What we get is an “abstract flowgraph” where the remaining variables are connected by complicated processes given by the elements in the semantic domain. In order to deal with such a case we are using flownomial expressions over certain abstract connecting theories.

Here the following extension is used. Suppose  $D$  is a set of value-vectors which represent the memory states of a computing device. Now, if we have given an interpretation of the variables in  $X$ , then we get an interpretation of a flownomial  $E : m \rightarrow n$  over  $X$  and  $\mathbb{R}el$  as a relation

$$E_I \subseteq ([m] \times D) \times ([n] \times D)$$

with the meaning that

$$((j, d), (j', d')) \in E_I$$

if and only if

“if one runs the program obtained from the expression  $E$  and the interpretation  $I$  starting with the input  $j$  of the program and using the initial state of memory  $d$ , then the program finishes on the exit  $j'$  of the program and has the corresponding memory state  $d'$ , eventually”

This observation leads to the construction of a semantic model  $\mathbb{R}el(D)$  defined as follows.

**Definition 4.7** (One-sorted relations with states)

We denote by  $\mathbb{R}el(D)$  the structure defined by the following data:

$$\mathbb{R}el(D)(m, n) = \{r : r \subseteq ([m] \times D) \times ([n] \times D)\}, \text{ for } m, n \in \mathbb{N}$$

The operations we are interested in have the following meaning in  $\mathbb{R}el(D)$ :

- **SUMMATION:** for  $m, n, p, q \in \mathbb{N}$ ,  $r \in \mathbb{R}el(D)(m, n)$  and  $r' \in \mathbb{R}el(D)(p, q)$  the sum  $r \oplus r' \in \mathbb{R}el(D)(m + p, n + q)$  is defined by

$$r \oplus r' = r \cup \{((m + j, d), (n + j', d')) : ((j, d), (j', d')) \in r'\}.$$

- **COMPOSITION:** for  $m, n, p \in \mathbb{N}$ ,  $r \in \mathbb{R}el(D)(m, n)$  and  $r' \in \mathbb{R}el(D)(n, p)$  the composite  $r \cdot r' \in \mathbb{R}el(D)(m, p)$  is the usual one defined by

$$r \cdot r' = \{((j, d), (j', d')) : \exists (j_0, d_0) \in [n] \times D : ((j, d), (j_0, d_0)) \in r \text{ and } (j_0, d_0), (j', d') \in r'\}$$

- **FEEDBACK:** In order to define the feedback first we notice that a relation  $r \in \mathbb{R}el(D)(m, n)$  is given by a family of relations  $r_{i,j} \subseteq D \times D$ , for  $i \in [m]$ ,  $j \in [n]$ , where the relations  $r_{i,j}$  have the following definition:

$$r_{i,j} = \{(d, d') : ((i, d), (j, d')) \in r\}$$

If  $s^*$  denotes the reflexive-transitive closure of a relation  $s \subseteq D \times D$ ,<sup>2</sup> then for  $r \in \mathbb{R}el(D)(m + 1, n + 1)$  the feedback  $r \uparrow \in \mathbb{R}el(D)(m, n)$  is defined by

$$(r \uparrow)_{i,j} = r_{i,j} \cup (r_{i,n+1} \cdot r_{m+1,n+1}^* \cdot r_{m+1,j}), \quad \text{for } i \in [m], j \in [n] \quad \square$$

---

<sup>2</sup>Namely,  $s^* = 1_D \cup s \cup s \cdot s \cup s \cdot s \cdot s \cup \dots$ , where  $1_D = \{(d, d) : d \in D\}$ .

Table 4.2: Axioms for constants  $l_a$  and  ${}^aX^b$ .

C1	$l_{a \oplus b} = l_a \oplus l_b$
C2	${}^0X^a = l_a$
C3	${}^aX^{b \oplus c} = ({}^aX^b \oplus l_c) \cdot (l_b \oplus {}^aX^c)$
C4	$l_a \uparrow^a = l_0$
C5	${}^aX^a \uparrow^a = l_a$

Let us note that  $\mathbb{R}el$  is naturally embedded in  $\mathbb{R}el(D)$  by the application

$$r \longrightarrow \{(i, d), (j, d) : (i, j) \in r \text{ and } d \in D\}$$

i.e., a usual relation in  $\mathbb{R}el$  is interpreted as a state transforming relation which actually do not change the state. This application preserves summation, composition, and feedback.

In the case of deterministic flowchart schemes the standard model for the interpretation of flownomials is  $\mathbb{P}fn(D)$ , which is the substructure of  $\mathbb{R}el(D)$  defined by the partially defined functions included in  $\mathbb{R}el(D)$ .

## 4.4 Structure of $a\alpha$ -flow

It is obvious that the  $a\alpha$ -Flow-Calculus defined in 2.1 has sense not only for the support theories  $T$  included in  $\mathbb{R}el$ , but also for other theories, for example for substructures in  $\mathbb{R}el(D)$  defined above. In this latter case the flownomial expressions represent mixed programs in which some parts are known, while other parts are yet unspecified (variable).

Now the question is:

What conditions should satisfy an abstract structure  $T$  in order to construct the calculus of flownomials?

Since the rules R1-R9 in Table 4.1 are valid for expressions containing only elements in  $T$ , it follows that the identities R1-R9 should hold in  $T$ . On the other part,  $T$  should contain the constants of type  $l_n$  and  ${}^mX^n$  which occur in the writing of the identities R1-R9 and must have a similar behaviour as in  $\mathbb{B}i$ . This latter purpose is fulfilled if one adds identities C1-C5 in Table 4.2 to the identities R1-R9.

The resulting algebraic structure  $(T, \oplus, \cdot, \uparrow, l_m, {}^mX^n)$  obeying R1–R9, SV1–SV2 and C1–C5 is called  $a\alpha$ -flow (over  $\mathbb{N}$ ). A *morphism of  $a\alpha$ -flows over  $\mathbb{N}$* , say  $H : T \rightarrow T'$ , is defined by a family of applications  $H_{m,n} : T(m, n) \rightarrow T'(m, n)$ , for  $m, n \in \mathbb{N}$ , which preserve the operations and the constants.

The following theorems justify the observations done in the beginning of this subsection.

**Theorem 4.8** *The models  $\mathbb{R}el(D)$  are  $a\alpha$ -flows over  $\mathbb{N}$ .  $\square$*

**Theorem 4.9** *The structure  $\mathbb{B}i$  is the initial  $a\alpha$ -flow, i.e. for every  $a\alpha$ -flow  $T$  over  $\mathbb{N}$  there exists a unique morphism of  $a\alpha$ -flows over  $\mathbb{N}$  from  $\mathbb{B}i$  to  $T$ .*



**Proof:** (Hint) The difficult part of the proof is to show the theorem without feedback holds. This fact has been proved in the previous chapter (Corollary 2.6). The extension to the case where the feedback operations is also present will follow as a particular case of a general theorem of the next chapter (i.e., case  $a\alpha$  of Theorem 6.4).  $\square$

We finish this subsection with a double extension: The monoid of natural numbers used to specify the inputs and the outputs of the flownomials is replaced by an arbitrary monoid  $(M, \oplus, 0)$ , so we get  $a\alpha$ -flows over an arbitrary monoid. On the other hand we enlarge the class of morphisms by allowing to change the number or sorts of the inputs and the outputs.

**Definition 4.10** ( $a\alpha$ -flow)

We say an abstract structure  $T = (T, \oplus, \cdot, \uparrow, \lfloor_a, {}^a\mathbf{X}^b)$  given by  $(a, b, c \in M)$  :

- $T = \{T(a, b)\}_{a, b \in M}$ ,
- constants:
  - $\lfloor_a \in T(a, a), \quad {}^a\mathbf{X}^b \in T(a \oplus b, b \oplus a),$
- operations:
  - $\oplus : T(a, b) \times T(c, d) \rightarrow T(a \oplus c, b \oplus d),$
  - $\cdot : T(a, b) \times T(b, c) \rightarrow T(a, c), \quad \text{and}$
  - $\uparrow^c : T(a \oplus c, b \oplus c) \rightarrow T(a, b)$

is an  $a\alpha$ -flow over  $M$  (or  $M$ - $a\alpha$ -flow) if it fulfills the identities R1-R9 in Table 4.1, the axioms for constants C1–C5 listed in Table 4.2, and

$$\text{SV1} \quad f \uparrow^0 = f$$

$$\text{SV2} \quad f \uparrow^{b \uparrow^a} = f \uparrow^{a \oplus b}.$$

A morphism of  $a\alpha$ -flows  $H : T \rightarrow T'$ , where  $T$  is an  $M$ - $a\alpha$ -flow and  $T'$  is an  $M'$ - $a\alpha$ -flow, is defined by a morphism of monoids  $h : M \rightarrow M'$  and a family of applications  $H_{m,n} : T(m, n) \rightarrow T'(h(m), h(n))$ , for  $m, n \in M$  preserving the operations, i.e.,

$$H(f \oplus g) = H(f) \oplus H(g); \quad H(f \cdot g) = H(f) \cdot H(g); \quad H(f \uparrow^p) = H(f) \uparrow^{h(p)};$$

$$H(\lfloor_a) = \lfloor_{h(a)}, \quad H({}^m\mathbf{X}^n) = {}^{h(m)}\mathbf{X}^{h(n)}.$$

$\square$

The additional axioms C1–C5 and SV1–SV2 are illustrated in Figure 4.6

Actually an  $a\alpha$ -flow is an  $a\alpha$ -ssmc endowed with a feedback operation satisfying the axioms R7–R9, C4–C5, and SV1–SV2.

An example of such an  $a\alpha$ -flow is the extension of the above model  $\mathbb{R}\text{el}(D)$  to the multi-sorted case. Namely, if  $S$  is a set of sorts, then we build the  $S^*$ - $a\alpha$ -flow  $\mathbb{R}\text{el}_S(D)$  as follows. For  $a, b \in S^*$  we define:

$$\mathbb{R}\text{el}_S(D)(a, b) = \{r : r \subseteq ([|a|] \times D) \times ([|b|] \times D) \text{ and } [((j, d), (j', d')) \in r \Rightarrow a_j = b_{j'}]\}$$

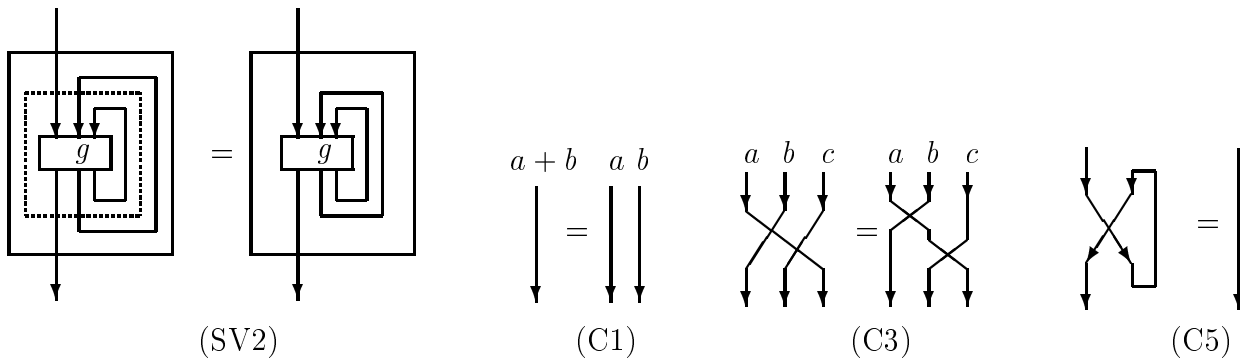

Figure 4.6: Additional axioms for  $a\alpha$ -flow

for  $a, b \in S^*$ . The definition of the operations and the constants is as in the one-sorted case  $\mathbb{R}el(D)$ .

For these general  $a\alpha$ -flows the above theorems have the following form.

**Theorem 4.11**  $\mathbb{R}el_S(D)$  is an  $S^*$ - $a\alpha$ -flow.  $\square$

**Theorem 4.12** If  $T$  is an  $M$ - $a\alpha$ -flow and  $h : S^* \rightarrow M$  is a morphism of monoids, then there exists a unique morphism of  $a\alpha$ -flows  $H$  from the  $S^*$ -flow of multisorted finite bijections  $\mathbb{B}i_S$  to  $T$  such that  $H$  acts on objects as  $h$ .  $\square$

A consequence of Theorem 4.12 is the following fact:

*If two expressions built up with “ $\oplus$ ”, “ $\cdot$ ”, “ $\uparrow$ ”,  $\downarrow_a$  and  ${}^aX^b$  represent the same bijection when they are interpreted in  $\mathbb{B}i_S$ , then they specify the same morphism when they are interpreted in an arbitrary  $a\alpha$ -flow.*

## 4.5 Short comments and references

The first axiomatic looping operation was ‘Kleene’s star’ introduced in [Kle56] and used as a key operation of regular algebras, see [Con71].

Another axiomatic looping operation is ‘Elgot dagger’ introduced in [Elg75] as the key operation of iterative algebraic theories.

The present axiomatic feedback ‘uparrow’ was introduced in [Ste86/90]. [Looping operations similar to our feedback may be found in various places, e.g. in [Con71] (the ‘linear mechanism’) or [Bai76], but not in an axiomatic setting using ssmc’s. If stronger structures than ssmc’s are used, then the possibility to get an algebra for flowgraphs themselves is lost.]

The normal form flonomial expressions are introduced in [Ste86, Ste86/90]. In the general form they are presented in [CaS90a]. The presentation from this chapter follows the one in Chapter B, sec. 1–2 of [Ste91].

# Chapter 5

## Algebra of flowgraphs ( $a\alpha$ -flow)

In this chapter we justify our claim that  $a\alpha$ -flownomials represent flowgraphs. Actually, this follows from the abstract correctness and completeness theorems proved in this chapter.

A concrete flowgraph may be identified with a class of isomorphic normal form expressions. In an abstract setting (i.e., in the case an arbitrary  $a\alpha$ -flow is used to connect the variables) this property is taken as the definition of abstract flowgraphs.

The correctness theorem take the following form: If we start with an  $a\alpha$ -flow  $T$  (for example  $\mathbb{R}el$ ), then the abstract flowgraphs over  $X$  and  $T$  form an  $a\alpha$ -flow, too.

The completeness theorem is based on two results: (1) every expression may be brought to a normal form using rules deductible from the  $a\alpha$ -flow axioms and (2) the rule of simulation via bijections (which allows to connect isomorphic normal forms) is deductible from the the  $a\alpha$ -flow axioms, too.

### 5.1 A canonical representation of flowgraphs

#### 5.1.1 The normal form representation

Every flowgraph (= labelled directed hypergraph) with atoms in  $X$ , for example the one in Figure 5.1 (a), may be redrawn in a standard way as in Figure 5.1 (b) by using the following method: <sup>1</sup>

- M1. Put all the atoms of the graph in a linear order chosen in an arbitrary way; in our example this order is  $x$  (top),  $y, z$ , and  $x$  (bottom).
- M2. Draw the rectangle  $f_{pic}$  and its external connections as follows: the parallel arrows 1, giving the inputs into the graph; the parallel arrows 2, giving the outputs from the graph; the parallel arrows 3 connecting the outputs of the atoms ro  $f_{pic}$ ; and the “parallel” backwards arrows 4 connecting  $f_{pic}$  to the inputs of the atoms.
- M3. Draw the arows inside the rectangle  $f_{pic}$  in such a way the connections in the resulted graph are the same as in the given one. (This operation is uniquely determinated by the linear order of the atoms.)

The resulted picture is called a *normal form picture*.

---

<sup>1</sup>For simplicity, the given example is within the omogen case, i.e. all the connection pins have the same sort. The extension to the many-sorted case is obvious.

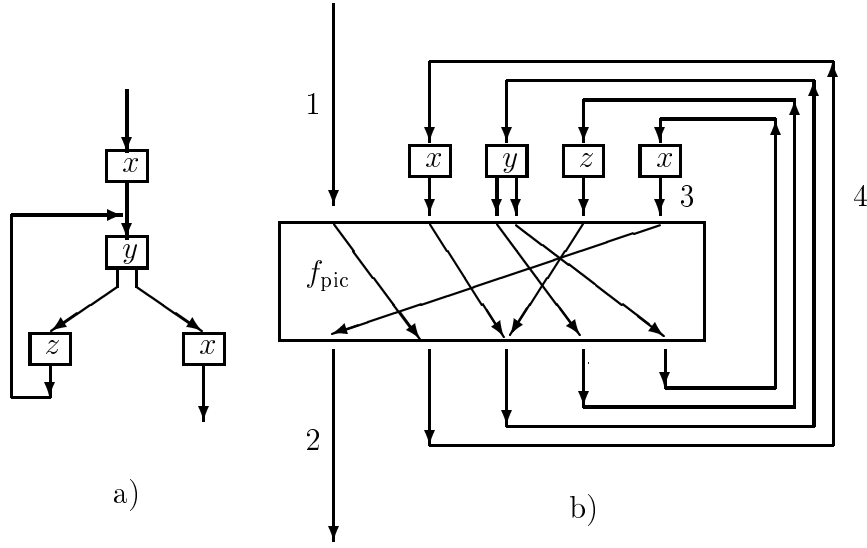

Figure 5.1: The normal form representation of flowgraphs

The arrows of the rectangle  $f_{\text{pic}}$  as above may be specified using a relation

$$f \in \mathbb{R}\text{el}(m + o(x_1) + \dots + o(x_k), n + i(x_1) + \dots + i(x_k)),$$

where  $m$  is the number of the inputs into the graph,  $n$  is the number of the outputs of the graph,  $(x_1, x_2, \dots, x_k)$  is the chosen sequence of all the atoms in the graph, and  $o(x)$  (resp.  $i(x)$ ), for an  $x$  in  $X$ , is the number of the inputs into (resp. the outputs from) the atom  $x$ . In the given example  $f \in \mathbb{R}\text{el}(1 + 1 + 2 + 1 + 1, 1 + 1 + 1 + 1 + 1) = \mathbb{R}\text{el}(6, 5)$  is the function which maps 1, 2, 3, 4, 5, 6 to 2, 3, 4, 5, 3, 1, respectively.

Since for  $p, q \in \mathbb{N}$  there exists a bijective correspondence between the set  $\mathbb{R}\text{el}(p, q)$  and the set of rectangles of arrows  $f_{\text{pic}}$  with  $p$  inputs and  $q$  outputs, the normal form pictures of flowgraphs are in a bijective correspondence with the pairs

$$(x_1 \oplus \dots \oplus x_k, f)$$

where  $x_1 \oplus \dots \oplus x_k$  is a word in  $X^*$ ,  $x_1, \dots, x_k \in X$  and  $f \in \mathbb{R}\text{el}(m + o(x_1) + \dots + o(x_k), n + i(x_1) + \dots + i(x_k))$ .

Actually, the normal form picture corresponding to the pair  $(x_1 \oplus \dots \oplus x_k, f)$  is

$$\text{gr}[(l_m \oplus x_1 \oplus \dots \oplus x_k) \cdot f \uparrow^{i(x_1) + \dots + i(x_k)}]$$

**Definition 5.1** (normal form expression, AC-pair; — for usual flowgraphs)

An expression as

$$((l_m \oplus x_1 \oplus \dots \oplus x_k) \cdot f \uparrow^{i(x_1) + \dots + i(x_k)})$$

is called a *normal form expression* and the corresponding pair

$$(x_1 \oplus \dots \oplus x_k, f)$$

is called an *AC-pair*. (Short for “pair consisting of a sequence of Atoms (variables) and a rectangle of Connections”).  $\square$

The following result is obvious.

**Lemma 5.2** *The nondeterministic (resp. partial, deterministic) flowgraphs, — in an intuitive sense —, built up with atoms in  $X$  coincide with the graphs of the type  $\mathbf{gr}(E)$ , where  $E$  is a normal form flownomial expression in  $\mathbb{F}\ell_{EXP}[X, \mathbb{R}el]$  (resp. in  $\mathbb{F}\ell_{EXP}[X, \mathbb{P}fn]$ ).  $\square$*

### 5.1.2 Relating different normal form representations

The aim of this analysis is to obtain a mathematical formulation of the property that two AC-pairs represent the same graph.

As we already noted, for a given graph and a given linear order of its atoms there is one and only one pair representing that graph. So the problem is to relate different pairs obtaining by varying the linear order used for atoms.

If  $F = (x_1 \oplus \dots \oplus x_k, f) : m \rightarrow n$  is an AC-pair, then it is easy to see that

$$F_{r \leftrightarrow (r+1)} := (x_1 \oplus \dots \oplus x_{r-1} \oplus x_{r+1} \oplus x_r \oplus x_{r+2} \oplus \dots \oplus x_k, f'),$$

where

$$\begin{aligned} f' &= (l_m \oplus l_{\Sigma_s < r, o(x_s)} \oplus o(x_{r+1})\mathbf{X}^{o(x_r)} \oplus l_{\Sigma_s > r+1, o(x_s)}) \\ &\quad \cdot f \cdot (l_n \oplus l_{\Sigma_s < r, i(x_s)} \oplus i(x_r)\mathbf{X}^{i(x_{r+1})} \oplus l_{\Sigma_s > r+1, i(x_s)}) \end{aligned}$$

is an AC-pair representing the same graph as  $F$ . Consequently,  $F_{r \leftrightarrow (r+1)}$  is *the* AC-pair corresponding to the given graph and the linear order  $x_1, \dots, x_{r-1}, x_{r+1}, x_r, x_{r+2}, \dots, x_k$ . This observation suggests the following definition.

**Definition 5.3** (simulation via a transposition; —for usual flowgraphs)

We say two AC-pairs  $F = (x_1 \oplus \dots \oplus x_k, f) : m \rightarrow n$  and  $F' = (x'_1 \oplus \dots \oplus x'_{k'}, f') : m \rightarrow n$  are *similar via a transposition*, and we write  $F \rightarrow_{Tr} F'$ , if  $k = k'$  and there exists an  $r$ , ( $r < k$ ) such that:

- (i)  $x'_i = x_i$ ,  $\forall i \in [k] - \{r, r+1\}$ ,  $x'_r = x_{r+1}$ , and  $x'_{r+1} = x_r$ ; and
- (ii) the connections are related by

$$\begin{aligned} f' &= (l_m \oplus l_{\Sigma_s < r, o(x_s)} \oplus o(x_{r+1})\mathbf{X}^{o(x_r)} \oplus l_{\Sigma_s > r+1, o(x_s)}) \\ &\quad \cdot f \cdot (l_n \oplus l_{\Sigma_s < r, i(x_s)} \oplus i(x_r)\mathbf{X}^{i(x_{r+1})} \oplus l_{\Sigma_s > r+1, i(x_s)}) \end{aligned}$$

The reflexive transitive closure of the relation  $\rightarrow_{Tr}$  is denoted by  $\Rightarrow_{Tr}$ . Sometimes we write

$$F \rightarrow_{Tr[r \leftrightarrow (r+1)]} F'$$

to single out the involved transposition.  $\square$

Now the following proposition is obvious.

**Proposition 5.4** *Two AC-pairs  $F$  and  $F'$  represent the same graph if and only if one may pass from one pair to the other one using a chain of simulations via transpositions, i.e. if and only if  $F \Rightarrow_{Tr} F'$ .  $\square$*

## 5.2 Correctness of $a\alpha$ -Flow-Calculus

It is clear that one may use pictures in order to show that the rules  $\text{RO}_T + \text{R1-R9} + \text{EqL}$  are correct, i.e., if two expressions are equivalent via these rules, then they represent the same graph, – see Figure 4.4. But there is also a mathematical method for proving this result. This procedure contains two steps:

- (i) Prove that the rules R1–R9 hold in  $\mathbb{R}\text{el}$ , and consequently in all of its substructures (i.e., containing constants “ $l_a$ ” and “ ${}^a\mathbf{X}^b$ ” and closed with respect to the operations “ $\oplus$ ”, “ $\cdot$ ” and “ $\uparrow$ ”).<sup>2</sup>
- (ii) Show that if the rules R1–R9 hold in  $T$ , then they hold in the theory of flowgraphs over  $X$  and  $T$ .

This frame for the proof of the correctness theorem has the advantage that it may be applied to the formal theory of abstract flowgraphs. We mean the following. The above analysis has shown that a concrete flowgraph (i.e., a flowgraph picture) may be represented by an AC-pair uniquely up to a chain of simulations via transpositions. But the notion of an AC-pair and of simulation via a transposition still have sense when the support theory is an arbitrary  $a\alpha$ -flow and not necessary an  $a\alpha$ -flow included in  $\mathbb{R}\text{el}$ .

**Notation 5.5** ( $\text{INF}\ell[X, T]$ ,  $\mathbb{F}\ell_{a\alpha}[X, T]$ )

$\text{INF}\ell[X, T]$  denotes the theory of AC-pairs over  $X$  and  $T$ .

If we denote by  $\rightarrow_{Tr}$  the simulation via a transposition, then it turns out that the congruence relation generated by  $\rightarrow_{Tr}$  is the reflexive-transitive closure of  $\rightarrow_{Tr}$ , denoted  $\Rightarrow_{Tr}$ .

$\mathbb{F}\ell_{a\alpha}[X, T]$  denotes  $\text{INF}\ell[X, T]/\Rightarrow_{Tr}$ .  $\square$

**Definition 5.6** (abstract flowgraph)

An *abstract flowgraph* is an element in  $\mathbb{F}\ell_{a\alpha}[X, T]$  ( $= \text{INF}\ell[X, T]/\Rightarrow_{Tr}$ ), where  $T$  is an arbitrary  $a\alpha$ -flow.  $\square$

In this abstract setting the difficult part of the correctness problem (i.e., (ii) above) take the following form:

“If  $T$  is an  $a\alpha$ -flow, is  $\mathbb{F}\ell_{a\alpha}[X, T]$  an  $a\alpha$ -flow, too?”

The answer is positive. The proof we shall give below use an equivalent definition for  $a\alpha$ -flow, where composition is restricted to left and right compositions with bijections.

### 5.2.1 An equivalent presentation for $a\alpha$ -flow.

In an  $a\alpha$ -flow composition may be written in terms of summation, feedback and right composition with morphisms of type  ${}^m\mathbf{X}^n$  as follows:

$$f \cdot g = [(f \oplus g) \cdot {}^n\mathbf{X}^p] \uparrow^n \quad \text{for } f : m \rightarrow n \text{ and } g : n \rightarrow p.$$

Consequently it may be useful to have a presentation of the  $a\alpha$ -flow structure using these operations only, but, unfortunately, the resulting axiom system we have has some unpleasant axioms. Due to this reason we give here an intermediary characterization of the  $a\alpha$ -flow structure which uses one more operation, namely left composition with bijections.

---

<sup>2</sup>This follows from Theorem 4.11.

**Definition 5.7** (LR-flow over  $\mathbb{B}i$ )

Let  $(M, \oplus, 0)$  be a monoid. We say a structure  $T = \{T(m, n)\}_{m, n \in M}$  endowed with:

- Identities  $\text{id}_m \in T(m, m)$ ;
- Summation  $\oplus : T(m, n) \times T(p, q) \rightarrow T(m \oplus p, n \oplus q)$ ;
- Feedback  $\uparrow^p : T(m \oplus p, n \oplus p) \rightarrow T(m, n)$ ;
- Right Composition with Morphisms in  $\mathbb{B}i$ :  
for  $f \in T(m, n)$ ,  $n = n_1 \oplus \dots \oplus n_k$  and  $\phi \in \mathbb{B}i(k, k)$

$$f \cdot_{R(n_1, \dots, n_k)} \phi \in T(m, n_{\phi^{-1}(1)} \oplus \dots \oplus n_{\phi^{-1}(k)})$$

- Left Composition with Morphisms in  $\mathbb{B}i$ :  
for  $f \in T(m, n)$ ,  $m = m_1 \oplus \dots \oplus m_k$  and  $\phi \in \mathbb{B}i(k, k)$

$$\phi \cdot_{L(m_1, \dots, m_k)} f \in T(m_{\phi(1)} \oplus \dots \oplus m_{\phi(k)}, n)$$

is a LR-flow over  $\mathbb{B}i$  if it fulfils the axioms in Table 5.1, SV1–SV2 and L- and R-REFINE defined below.

- R-REFINE  $f \cdot_{R(n_1, \dots, n_1^1 \oplus \dots \oplus n_1^l, \dots, n_k)} \phi = f \cdot_{R(n_1, \dots, n_1^1, \dots, n_1^l, \dots, n_k)} (\phi(1)_1 \dots \phi(i)_l \dots \phi(k)_1)$ ,  
for  $l = 0, 2^3$
- L-REFINE Similar

□

The aim of the next two lemmas is to show that the notions of  $a\alpha$ -flow and LR-flow over  $\mathbb{B}i$  coincide. The long, but easy proof, is given in Appendix 12.

**Lemma 5.8** ( $a\alpha$ -flow  $\Rightarrow$  LR-flow over  $\mathbb{B}i$ )

Suppose  $T = (\{T(m, n)\}_{m, n \in M}, \oplus, \cdot, \uparrow, \text{id}_m, {}^m X^n)$  is an  $a\alpha$ -flow. Then  $(T, \oplus, \cdot_L, \cdot_R, \uparrow, \text{id}_m)$  is a LR-flow over  $\mathbb{B}i$ , where

$$\begin{aligned} f \cdot_{R(n_1, \dots, n_k)} \phi &= f \cdot (\phi(1)_{n_1} \dots \phi(k)_{n_k}) \quad \text{and} \\ \phi \cdot_{L(m_1, \dots, m_k)} f &= (\psi(1)_{m_{\psi(1)}} \dots \psi(k)_{m_{\psi(k)}}) \cdot f \end{aligned}$$

(Recall the notation  $(\phi(1)_{c_1} \dots \phi(k)_{c_k})$ : Let  $S \supset \{s_1, \dots, s_k\}$  and  $\bar{\phi} \in \mathbb{B}i_S(s_1 \oplus \dots \oplus s_k, s_{\phi^{-1}(1)} \oplus \dots \oplus s_{\phi^{-1}(k)})$  be a multi-sorted bijection induced by  $\phi$ . Let  $H : \mathbb{B}i_S \rightarrow T$  be the unique morphism of  $a\alpha$ -flows (provided by Theorem 2.5) which extends the function  $h : S \rightarrow M$  that maps  $s_i$  to  $c_i$ , for every  $i \in [k]$ . Then  $(\phi(1)_{c_1} \dots \phi(k)_{c_k}) = H(\bar{\phi})$ . □

**Lemma 5.9** (LR-flow over  $\mathbb{B}i \Rightarrow a\alpha$ -flow)

Let  $(M, \oplus, 0)$  be a monoid. Suppose  $(\{T(m, n)\}_{m, n \in M}, \oplus, \cdot_L, \cdot_R, \uparrow, \text{id}_m)$  is a LR-flow over  $\mathbb{B}i$  and define:

---

<sup>3</sup>We recall that  $(\phi(1)_1 \dots \phi(i)_l \dots \phi(k)_1)$  is the bijection obtained from  $\phi$  replacing the arrow leaving the  $i$ -th entry by a group of  $l$  parallel arrows. See also the computation rules given just below Proposition 2.7.

Table 5.1: Axioms for LR-flow over  $\mathbb{B}i$ .

Here  $f, g, h$  vary in  $T$ ,  $\phi, \psi$  vary in  $\mathbb{B}i$  and the operations in  $\mathbb{B}i$  are denoted by  $\oplus, \circ, \uparrow, \mathbb{I}_k, {}^k\mathbb{X}^l$ .

In LR3a,b we are using the following notation: If  $P$  is the  $k$ -tuple  $(n_1, \dots, n_k)$  and  $\sigma \in \mathbb{B}i(k, k)$ , then  $\sigma(P)$  denotes  $(n_{\sigma^{-1}(1)}, \dots, n_{\sigma^{-1}(k)})$  and  $\sigma^{-1}(P)$  denotes  $(n_{\sigma(1)}, \dots, n_{\sigma(k)})$ .

LR1	$f \oplus (g \oplus h) = (f \oplus g) \oplus h$
LR2	$\mathbb{I}_0 \oplus f = f = f \oplus \mathbb{I}_0$
LR3a	$(f \cdot_{R(P)} \phi) \cdot_{R(\phi(P))} \psi = f \cdot_{R(P)} (\phi \circ \psi)$
LR3b	$\phi \cdot_{L(\psi^{-1}(P))} (\psi \cdot_{L(P)} f) = (\phi \circ \psi) \cdot_{L(P)} f$
LR3c	$\phi \cdot_{L(P)} (f \cdot_{R(Q)} \psi) = (\phi \cdot_{L(P)} f) \cdot_{R(Q)} \psi$
LR4a	$\mathbb{I}_k \cdot_{L(m_1, \dots, m_k)} f = f = f \cdot_{R(n_1, \dots, n_k)} \mathbb{I}_k \quad (k \geq 0)$
LR4b	$\mathbb{I}_{n_1 \oplus \dots \oplus n_k} \cdot_{R(n_1, \dots, n_k)} \phi = \phi \cdot_{L(n_{\phi^{-1}(1)}, \dots, n_{\phi^{-1}(k)})} \mathbb{I}_{n_{\phi^{-1}(1)} \oplus \dots \oplus n_{\phi^{-1}(k)}}$
LR5a	$(f \oplus g) \cdot_{R(P, Q)} (\phi \oplus \psi) = (f \cdot_{R(P)} \phi) \oplus (g \cdot_{R(Q)} \psi)$
LR5b	$(\phi \oplus \psi) \cdot_{L(P, Q)} (f \oplus g) = (\phi \cdot_{L(P)} f) \oplus (\psi \cdot_{L(Q)} g)$
LR6	$f \oplus g = [{}^1\mathbb{X}^1 \cdot_{L(n, m)} (g \oplus f)] \cdot_{R(q, p)} {}^1\mathbb{X}^1$ for $f : m \rightarrow p, g : n \rightarrow q$
LR7a	$\phi \cdot_{L(P)} f \uparrow^p = [(\phi \oplus \mathbb{I}_1) \cdot_{L(P, p)} f] \uparrow^p$
LR7b	$f \uparrow^p \cdot_{R(P)} \phi = [f \cdot_{R(P, p)} (\phi \oplus \mathbb{I}_1)] \uparrow^p$
LR7c	$f \cdot_{R(P)} (\phi \uparrow^1) = [(f \oplus \mathbb{I}_p) \cdot_{R(P, p)} \phi] \uparrow^p$ when $P = (n_1, \dots, n_k)$ and $p = n_{\phi^{-1}(k+1)}$ when $\phi^{-1}(k+1) \leq k$
LR7d	$(\phi \uparrow^1) \cdot_{L(P)} f = [\phi \cdot_{L(P, p)} (f \oplus \mathbb{I}_p)] \uparrow^p$ when $P = (n_1, \dots, n_k)$ and $p = n_{\phi(k+1)}$ if $\phi(k+1) \leq k$
LR8	$f \oplus g \uparrow^p = (f \oplus g) \uparrow^q$
LR9	$[f \cdot_{R(n, p, q)} (\mathbb{I}_1 \oplus {}^1\mathbb{X}^1)] \uparrow^{q \oplus p} = [(\mathbb{I}_1 \oplus {}^1\mathbb{X}^1) \cdot_{L(m, q, p)} f] \uparrow^{p \oplus q}$ for $f : m \oplus q \oplus p \rightarrow n \oplus p \oplus q$



(DEF) for  $f : m \rightarrow n$  and  $g : n \rightarrow p$

$$f \cdot g = [(f \oplus g) \cdot_{R(n,p)} {}^1\mathbb{X}^1] \uparrow^n$$

and

$${}^p\mathbb{X}^q = \downarrow_{p \oplus q} \cdot_{R(p,q)} {}^1\mathbb{X}^1$$

Then  $T = (\{T(m, n)\}_{m,n \in M}, \oplus, \cdot, \uparrow, \downarrow, {}^m\mathbb{X}^n)$  is an  $a\alpha$ -flow.  $\square$

**Fact 5.10** (Left Feedback)

In the definition of a LR-flow one may use a Left Feedback “ $\uparrow \_$ ” instead of the Right Feedback “ $\_ \uparrow$ ” that we have used. In such a case the axioms LR7a–d, LR8 and LR9 are replaced with the following ones:

$$\begin{aligned} \phi \cdot_{L(P)} (\uparrow^p f) &= \uparrow^p [(l_1 \oplus \phi) \cdot_{L(p,P)} f] \\ (\uparrow^p f) \cdot_{R(P)} \phi &= \uparrow^p [f \cdot_{R(p,P)} (l_1 \oplus \phi)] \\ f \cdot_{R(P)} (\uparrow^1 \phi) &= \uparrow^p [(l_p \oplus f) \cdot_{R(p,P)} \phi] \\ (\uparrow^1 \phi) \cdot_{L(P)} f &= \uparrow^p [\phi \cdot_{L(p,P)} (l_p \oplus f)] \\ (\uparrow^p f) \oplus g &= \uparrow^p (f \oplus g) \\ \uparrow^{t \oplus s} (f \cdot_{R(s,t,n)} ({}^1\mathbb{X}^1 \oplus \mathbb{1}_1)) &= \uparrow^{s \oplus t} [({}^1\mathbb{X}^1 \oplus \mathbb{1}_1) \cdot_{L(t,s,m)} f] \end{aligned}$$

with compatibility relationships between  $p$  and  $P$  in the third and fourth lines similar to those for the right feedback.

The connection between these two feedbacks is given by the following relations

$$\begin{aligned} \uparrow^p f &= [{}^1\mathbb{X}^1 \cdot_{L(p,m)} f \cdot_{R(p,n)} {}^1\mathbb{X}^1] \uparrow^p \quad \text{for } f : p \oplus m \rightarrow p \oplus n \\ f \uparrow^p &= \uparrow^p [{}^1\mathbb{X}^1 \cdot_{L(m,p)} f \cdot_{R(n,p)} {}^1\mathbb{X}^1] \quad \text{for } f : m \oplus p \rightarrow n \oplus p \quad \square \end{aligned}$$

We collect the above results in the following theorem.

**Theorem 5.11** (equivalence of two presentations of  $a\alpha$ -flow)

The following two sets of axioms are equivalent (and define the structure of  $a\alpha$ -flow):

- (i) identities R1–R9 in Table 4.1, SV1–SV2 and C1–C5 in Table 4.2,
- (ii) identities in Table 5.1, SV1–SV2, C1 and L- and R-REFINE.

(The passage from left and right compositions used in Table 5.1 to the general composition is made the rule (DEF) given in Lemma 12.2.)  $\square$

## 5.2.2 Flowgraphs as isomorphic normal form expressions; algebra $\mathbb{F}\ell_{a\alpha}[X, T]$

In this subsection we show how the normal form expressions / AC-pairs may be structured as an  $a\alpha$ -flow. Suppose we are given an  $X$  and an  $a\alpha$ -flow  $T$ . The theory  $\text{INF}\ell[X, T]$  of AC-pairs over  $X$  and  $T$  is defined by the sets

$$\begin{aligned} \text{INF}\ell[X, T](m, n) &= \{(x_1 \oplus \dots \oplus x_k, f) : \\ &\quad \text{with } x_1 \oplus \dots \oplus x_k \text{ word in } X^*, \\ &\quad x_1, \dots, x_k \text{ variables in } X \text{ and} \\ &\quad f \in T(m \oplus o(x_1) \oplus \dots \oplus o(x_k), n \oplus i(x_1) \oplus \dots \oplus i(x_k))\} \end{aligned}$$

When  $k = 0$  the sum  $x_1 \oplus \dots \oplus x_k$  is interpreted as the empty word, – denoted by  $\lambda$ .

In order to define the operations on AC-pairs we use the convention that  $\underline{x}, i(\underline{x}), \underline{x}'$ , etc denote  $x_1 \oplus \dots \oplus x_k, i(x_1) \oplus \dots \oplus i(x_k), x'_1 \oplus \dots \oplus x'_{k'}$ , etc., respectively. In addition we think of the  $\alpha\alpha$ -flow  $T$  as being defined by the identities in Table 5.1, hence the morphisms in  $T$  may be composed on left and on right with bijections in  $\mathbb{B}i$ .

- **Summation:** for  $(\underline{x}, f) \in \text{NF}\ell[X, T](m, n)$  and  $(\underline{x}', f') \in \text{NF}\ell[X, T](p, q)$  we define:

$$(\underline{x}, f) \oplus (\underline{x}', f') = (\underline{x} \oplus \underline{x}', (\mathbb{1}_1 \oplus^1 \mathbb{X}^1 \oplus \mathbb{1}_1) \cdot_{L(m, o(\underline{x}), p, o(\underline{x}'))} (f \oplus f') \cdot_{R(n, i(\underline{x}), q, i(\underline{x}'))} (\mathbb{1}_1 \oplus^1 \mathbb{X}^1 \oplus \mathbb{1}_1))$$

- **Right composition with morphisms from  $\mathbb{B}i$ :** for  $(\underline{x}, f) \in \text{NF}\ell[X, T](m, n)$ ,  $n = n_1 \oplus \dots \oplus n_k$  and  $\phi \in \mathbb{B}i(k, k)$  we define

$$(\underline{x}, f) \cdot_{R(P)} \phi = (\underline{x}, f \cdot_{R(P, i(\underline{x}))} (\phi \oplus \mathbb{1}_1))$$

- **Left composition with morphisms from  $\mathbb{B}i$ :** for  $(\underline{x}, f) \in \text{NF}\ell[X, T](n, p)$ ,  $n = n_1 \oplus \dots \oplus n_k$  and  $\phi \in \mathbb{B}i(k, k)$  we define

$$\phi \cdot_{L(P)} (\underline{x}, f) = (\underline{x}, (\phi \oplus \mathbb{1}_1) \cdot_{L(P, o(\underline{x}))} f)$$

- **(Left) Feedback:** for  $(\underline{x}, f) \in \text{NF}\ell[X, T](p \oplus m, p \oplus n)$  we define

$$\uparrow^p (\underline{x}, f) = (\underline{x}, \uparrow^p f)$$

Let us note that  $X$  and  $T$  are naturally embedded in  $\text{NF}\ell$  by

for  $x \in X(m, n)$

$$E_X(x) = (x, {}^m \mathbb{X}^n)$$

and for  $f \in T(m, n)$

$$E_T = (\lambda, f)$$

The definition of simulation via a transposition  $\rightarrow_{Tr}$  on the sets  $\text{NF}\ell[X, T](m, n)$  has been given in Definition 5.3 in the particular case  $T \subseteq \mathbb{R}el$ , but it still has sense when  $T$  is an arbitrary  $\alpha\alpha$ -flow.

**Lemma 5.12** *Let  $T$  be an  $\alpha\alpha$ -flow. Relation  $\rightarrow_{Tr}$  is a symmetric relation on  $\text{NF}\ell[X, T]$  and obeys the following conditions:*

$$\begin{array}{ll} \text{a)} & \begin{array}{l} F' \oplus F \xrightarrow{Tr[r \leftrightarrow (r+1)]} F'' \oplus F \\ F \oplus F' \xrightarrow{Tr[(k+r) \leftrightarrow (k+r+1)]} F \oplus F'' \end{array} \text{ where } F = (x_1 \oplus \dots \oplus x_k, f) \\ \text{b)} & \begin{array}{l} F' \cdot_{R(P)} \phi \xrightarrow{Tr[r \leftrightarrow (r+1)]} F'' \cdot_{R(P)} \phi \\ \phi \cdot_{L(P)} F' \xrightarrow{Tr[r \leftrightarrow (r+1)]} \phi \cdot_{L(P)} F'' \end{array} \\ \text{c)} & \begin{array}{l} \uparrow^p F' \xrightarrow{Tr[r \leftrightarrow (r+1)]} \uparrow^p F'' \end{array} \end{array}$$

whenever  $F' \rightarrow_{Tr[r \leftrightarrow (r+1)]} F''$  and the corresponding operations make sense.  $\square$

The proof of the above lemma is simple and it is omitted. By applying this lemma we get the following result.

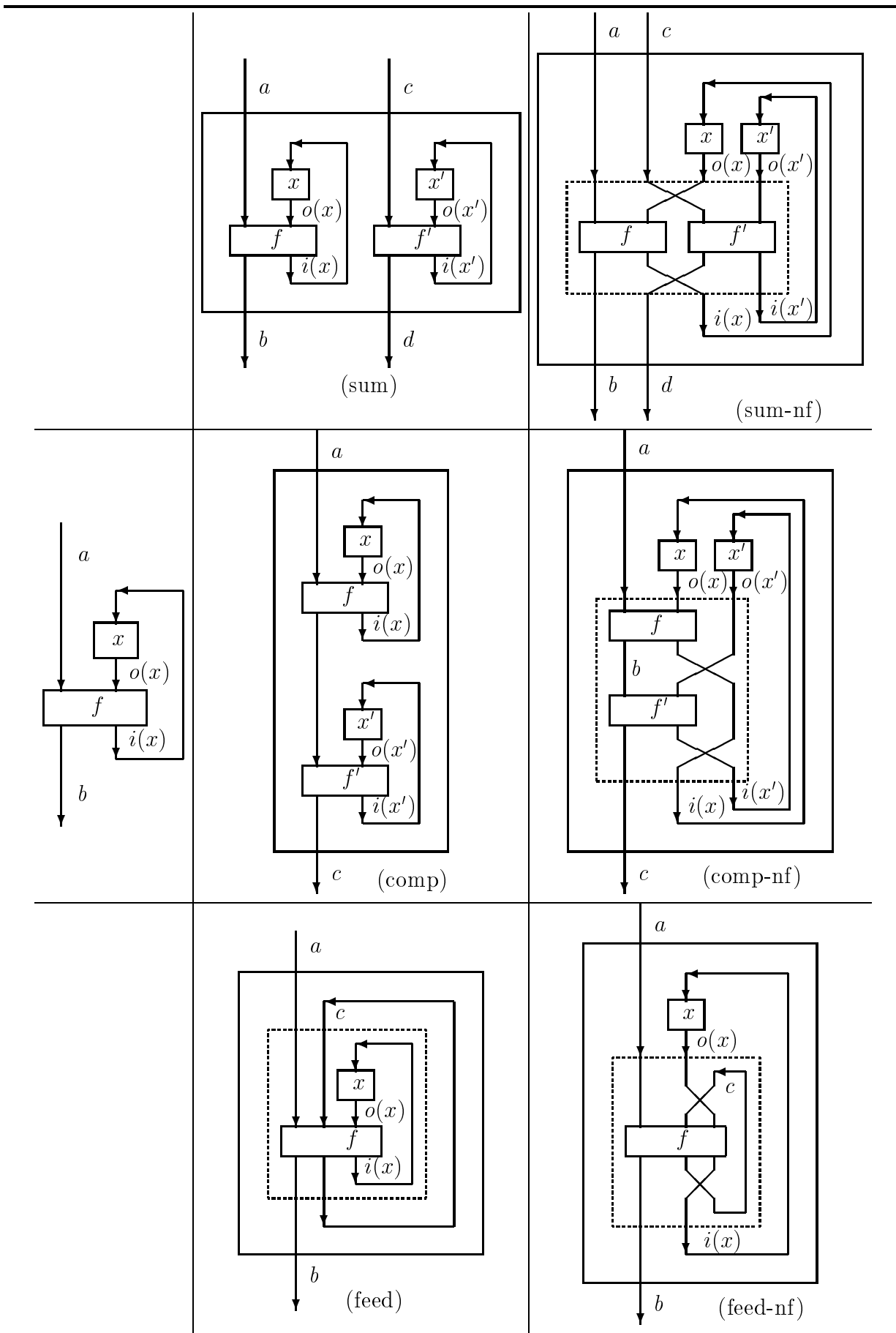

Figure 5.2: Operations on normal forms representations

**Proposition 5.13** *The congruence relation generated by  $\rightarrow_{Tr}$  on  $\text{NF}\ell[X, T]$  is the reflexive-transitive closure of  $\rightarrow_{Tr}$ , denoted by  $\Rightarrow_{Tr}$ .  $\square$*

Consequently the operations defined on  $\text{NF}\ell[X, T]$  still make sense when they are interpreted in the quotient structure  $\text{NF}\ell[X, T]/\Rightarrow_{Tr}$ .

**Definition 5.14** (simulation via block transpositions; abstract case)

We say two AC-pairs  $f = (x_1 \oplus \dots \oplus x_k, f) : m \rightarrow n$  and  $f' = (x'_1 \oplus \dots \oplus x'_{k'}, f') : m \rightarrow n$  are *similar via a block transposition*  $[(r+1, \dots, r+s) \leftrightarrow (r+s+1, \dots, r+s+t)]$  with  $s, t \geq 1$ ,  $1 \leq r+1$  and  $r+s+t \leq k$  if

$k = k'$  and the following conditions holds:

- (i)  $x'_1 = x_1, \dots, x'_r = x_r; x'_{r+1} = x_{r+s+1}, \dots, x'_{r+t} = x_{r+s+t};$   
 $x'_{r+t+1} = x_{r+1}, \dots, x'_{r+t+s} = x_{r+s}; x'_{r+t+s+1} = x_{r+t+s+1}, \dots, x'_k = x_k$

(ii)

$$f' = (\mathbb{I}_2 \oplus \mathbb{1} \mathbb{X}^1 \oplus \mathbb{I}_1) \cdot L(m, \Sigma_{u < r} o(x_u), o(x_{r+1}) \oplus \dots \oplus o(x_{r+s}), o(x_{r+s+1}) \oplus \dots \oplus o(x_{r+s+t}), \Sigma_{u > r+s+t} o(x_u)) f \\ \cdot R(n, \Sigma_{u < r} i(x_u), i(x_{r+1}) \oplus \dots \oplus i(x_{r+s}), i(x_{r+s+1}) \oplus \dots \oplus i(x_{r+s+t}), \Sigma_{u > r+s+t} i(x_u)) (\mathbb{I}_2 \oplus \mathbb{1} \mathbb{X}^1 \oplus \mathbb{I}_1)$$

$\square$

It is easy to see that this simulation via block transpositions may be replaced by a chain of simulations via simple transpositions. Hence, if the above simulation is denoted by

$$\longrightarrow_{Tr[(r+1, \dots, r+s) \leftrightarrow (r+s+1, \dots, r+s+t)]}$$

then

$$\longrightarrow_{Tr[(r+1, \dots, r+s) \leftrightarrow (r+s+1, \dots, r+s+t)]} \subseteq \Rightarrow_{Tr}$$

### 5.2.3 Extending $a\alpha$ -flow structure from connections to flow-graphs

The proof of this result is based on the following two lemmas.

**Lemma 5.15** *If  $T$  is an LR-flow over  $\mathbb{B}i$ , then all the axioms in Table 5.1, except for the axiom LR6, hold in  $\text{NF}\ell[X, T]$ .*

**Proof:** For LR1 suppose we are give three pairs in  $\text{NF}\ell[X, T]$ , namely  $(\underline{x}, f) : m \rightarrow n$  with  $\underline{x} : r \rightarrow s$ ,  $(\underline{x}', f') : m' \rightarrow n'$  with  $\underline{x}' : r' \rightarrow s'$ , and  $(\underline{x}'', f'') : m'' \rightarrow n''$  with  $\underline{x}'' : r'' \rightarrow s''$ . Then

$$[(\underline{x}, f) \oplus (\underline{x}', f')] \oplus (\underline{x}'', f'') = (\underline{x} \oplus \underline{x}' \oplus \underline{x}'', g)$$

where

$$g = (1324) \cdot L(m \oplus m', s \oplus s', m'', s'') [(1324) \cdot L(m, s, m', s') (f \oplus f') \\ \cdot R(n, r, n', r') (1324) \oplus f''] \cdot R(n \oplus n', r \oplus r', n'', r'') (1324) \\ = (125346) \cdot L(m, m', s, s', m'', s'') [(132456) \cdot L(m, s, m', s', m'', s'') (f \oplus f' \oplus f'') \\ \cdot R(n, r, n', r', n'', r'') (132456)] \cdot R(n, n', r, r', n'', s'') (124536) \\ = (135246) \cdot L(m, s, m', s', m'', s'') (f \oplus f' \oplus f'') \cdot R(n, r, n', r', n'', r'') (142536)$$

In a similar way one get

$$(\underline{x}, f) \oplus [(\underline{x}', f') \oplus (\underline{x}'', f'')] = (\underline{x} \oplus \underline{x}' \oplus \underline{x}'', g)$$

hence axiom LR1 holds in  $\text{INF}\ell[X, T]$ , too.

LR2 holds in  $\text{INF}\ell[X, T]$  since for  $(\underline{x}, f) : m \rightarrow n$  with  $\underline{x} : r \rightarrow s$

$$\begin{aligned} (\underline{x}, f) \oplus (\lambda, \mathbb{1}_0) &= (\underline{x}, (1324) \cdot_{L(m,s,0,0)} (f \oplus \mathbb{1}_0) \cdot_{R(n,r,0,0)} (1324)) \\ &= (\underline{x}, f \oplus \mathbb{1}_0) && \text{by REFINE} \\ &= (\underline{x}, f) \end{aligned}$$

and similarly for the other equality.

For LR3, suppose we are given a pair  $(\underline{x}, f) : m \rightarrow n$  with  $\underline{x} : r \rightarrow s$ . Then LR3a holds by

$$\begin{aligned} ((\underline{x}, f) \cdot_{R(P)} \phi) \cdot_{R(\phi(P))} \psi &= (\underline{x}, [f \cdot_{R(P,r)} (\phi \oplus \mathbb{1}_1)] \cdot_{R(\phi(P),r)} (\psi \oplus \mathbb{1}_1)) \\ &= (\underline{x}, f \cdot_{R(P,r)} (\phi \circ \psi \oplus \mathbb{1}_1)) \\ &= (\underline{x}, f) \cdot_{R(P)} (\phi \circ \psi) \end{aligned}$$

LR3b is dual to LR3a. LR3c follows by

$$\begin{aligned} [(\phi \cdot_{L(Q)} (\underline{x}, f))] \cdot_{R(P)} \psi &= (\underline{x}, [(\phi \oplus \mathbb{1}_1) \cdot_{L(Q,s)} f] \cdot_{R(P,s)} (\psi \oplus \mathbb{1}_1)) \\ &= (\underline{x}, (\phi \oplus \mathbb{1}_1) \cdot_{L(Q,s)} [f \cdot_{R(P,s)} (\psi \oplus \mathbb{1}_1)]) \\ &= \phi \cdot_{L(Q)} [(\underline{x}, f) \cdot_{R(P)} \psi] \end{aligned}$$

For LR4a, if  $(\underline{x}, f) : m \rightarrow n$  with  $\underline{x} : r \rightarrow s$  and  $m = m_1 \oplus \dots \oplus m_k$ , then

$$\begin{aligned} \mathbb{1}_k \cdot_{R(m_1, \dots, m_k)} (\underline{x}, f) &= (\underline{x}, \mathbb{1}_{k+1} \cdot_{R(m_1, \dots, m_k, s)} f) \\ &= (\underline{x}, f) \end{aligned}$$

and similarly for the other equality. For LR4b, if  $\phi \in \mathbb{B}i(k, k)$ , then

$$\begin{aligned} (\lambda, \mathbb{1}_{n_1 \oplus \dots \oplus n_k}) \cdot_{R(n_1, \dots, n_k)} \phi &= (\lambda, \mathbb{1}_{n_1 \oplus \dots \oplus n_k} \cdot_{R(n_1, \dots, n_k, 0)} (\phi \oplus \mathbb{1}_1)) \\ &= (\lambda, \mathbb{1}_{n_1 \oplus \dots \oplus n_k} \cdot_{R(n_1, \dots, n_k)} \phi) \\ &= (\lambda, \phi \cdot_{L(n_{\phi^{-1}(1)}, \dots, n_{\phi^{-1}(k)})} \mathbb{1}_{n_{\phi^{-1}(1)} \oplus \dots \oplus n_{\phi^{-1}(k)}}) \\ &= \phi \cdot_{L(n_{\phi^{-1}(1)}, \dots, n_{\phi^{-1}(k)})} (\lambda, \mathbb{1}_{n_{\phi^{-1}(1)} \oplus \dots \oplus n_{\phi^{-1}(k)}}) \end{aligned}$$

For LR5 suppose we are given the pairs  $(\underline{x}, f) : m \rightarrow n$  with  $\underline{x} : r \rightarrow s$ , and  $(\underline{x}', f') : m' \rightarrow n'$  with  $\underline{x}' : r' \rightarrow s'$ . If moreover  $P :: n = n_1 \oplus \dots \oplus n_k$ ,  $\phi \in \mathbb{B}i(k, k)$ ,  $p = n_{\phi^{-1}(1)} \oplus \dots \oplus n_{\phi^{-1}(k)}$  and  $P' :: n' = n'_1 \oplus \dots \oplus n'_{k'}$ ,  $\phi' \in \mathbb{B}i(k', k')$ ,  $p' = n'_{\phi'^{-1}(1)} \oplus \dots \oplus n'_{\phi'^{-1}(k')}$ , then LR5a follows by

$$\begin{aligned} [(\underline{x}, f) \oplus (\underline{x}', f')] \cdot_{R(P, P')} (\phi \oplus \psi) &= (\underline{x} \oplus \underline{x}', [(1324) \cdot_{L(m,s,m',s')} (f \oplus f')] \cdot_{R(n,r,n',r')} (1324)) \cdot_{R(P, P', r, r')} (\phi \oplus \phi' \oplus \mathbb{1}_1 \oplus \mathbb{1}_1)) \\ &= (\underline{x} \oplus \underline{x}', (1324) \cdot_{L(m,s,m',s')} (f \oplus f') \cdot_{R(P, r, P', r')} [(1_k 3_1 2_{k'} 4_1) \circ (\phi \oplus \phi' \oplus \mathbb{1}_1 \oplus \mathbb{1}_1)]) \\ &= (\underline{x} \oplus \underline{x}', (1324) \cdot_{L(m,s,m',s')} (f \oplus f') \cdot_{R(P, r, P', r')} [(\phi \oplus \mathbb{1}_1 \oplus \phi' \oplus \mathbb{1}_1) \circ (1_k 3_1 2_{k'} 4_1)]) \\ &= (\underline{x} \oplus \underline{x}', (1324) \cdot_{L(m,s,m',s')} [(f \oplus f') \cdot_{R(P, r, P', r')} (\phi \oplus \mathbb{1}_1 \oplus \phi' \oplus \mathbb{1}_1)] \cdot_{R(p, r, p', r')} (1324)) \\ &= (\underline{x}, f \cdot_{R(P, r)} (\phi \oplus \mathbb{1}_1)) \oplus (\underline{x}', f' \cdot_{R(P', r')} (\phi' \oplus \mathbb{1}_1)) \\ &= (\underline{x}, f) \cdot_{R(P)} \phi \oplus (\underline{x}', f') \cdot_{R(P')} \phi' \end{aligned}$$

The other identity LR5b follows by duality.

Next, the axioms for feedback. We prefer to prove the axioms for the Left Feedback and to use Fact 5.10.

For LR7a suppose we are given a pair  $(\underline{x}, f) : p \oplus m \rightarrow p \oplus n$  with  $\underline{x} : r \rightarrow s$ ,  $n = n_1 \oplus \dots \oplus n_k$  and  $\phi \in \mathbb{B}i(k, k)$ . Then

$$\begin{aligned} [\uparrow^p(\underline{x}, f)] \cdot_{R(P)} \phi &= (\underline{x}, (\uparrow^p f) \cdot_{R(P,r)} (\phi \oplus \mathbb{1}_1)) \\ &= (\underline{x}, \uparrow^p [f \cdot_{R(p,P,r)} (\mathbb{1}_1 \oplus \phi \oplus \mathbb{1}_1)]) \\ &= \uparrow^p [(\underline{x}, f) \cdot_{R(p,P)} (\mathbb{1}_1 \oplus \phi)] \end{aligned}$$

LR7b is dual to LR7a. For LR7c suppose we are given  $(\underline{x}, f) : m \rightarrow n$  with  $\underline{x} : r \rightarrow s$ ,  $n = n_1 \oplus \dots \oplus n_k$  and  $\phi \in \mathbb{B}i(1 \oplus k, 1 \oplus k)$ . If  $p = n_{\phi^{-1}(1)-1}$  when  $\phi^{-1}(1) \geq 1$ , then

$$\begin{aligned} (\underline{x}, f) \cdot_{R(P)} (\uparrow^1 \phi) &= (\underline{x}, f \cdot_{R(P,r)} ((\uparrow^1 \phi) \oplus \mathbb{1}_1)) \\ &= (\underline{x}, f \cdot_{R(P,r)} \uparrow^1(\phi \oplus \mathbb{1}_1)) \\ &= (\underline{x}, \uparrow^p [(l_p \oplus f) \cdot_{R(p,P,r)} (\phi \oplus \mathbb{1}_1)]) \\ &= \uparrow^p [(\underline{x}, l_p \oplus f) \cdot_{R(p,P)} \phi] \\ &= \uparrow^p [((\lambda, l_p) \oplus (\underline{x}, f)) \cdot_{R(p,P)} \phi] \end{aligned}$$

LR7d is dual to LR7c.

For LR8 suppose we are given the pairs  $(\underline{x}, f) : p \oplus m \rightarrow p \oplus n$  with  $\underline{x} : r \rightarrow s$  and  $(\underline{x}', f') : m' \rightarrow n'$  with  $\underline{x}' : r' \rightarrow s'$ . Then

$$\begin{aligned} \uparrow^p(\underline{x}, f) \oplus (\underline{x}', f') &= (\underline{x} \oplus \underline{x}', (1324) \cdot_{L(m,s,m',s')} (\uparrow^p f \oplus f') \cdot_{R(n,r,n',r')} (1324)) \\ &= (\underline{x} \oplus \underline{x}', \uparrow^p [(\mathbb{1}_1 \oplus (1324)) \cdot_{L(p,m,s,m',s')} (f \oplus f') \cdot_{R(p,n,r,n',r')} (\mathbb{1}_1 \oplus (1324))]) \\ &= (\underline{x} \oplus \underline{x}', \uparrow^p [(1324) \cdot_{L(p \oplus m,s,m',s')} (f \oplus f') \cdot_{R(p \oplus n,r,n',r')} (1324)]) \\ &= \uparrow^p [(\underline{x}, f) \oplus (\underline{x}', f')] \end{aligned}$$

For LR9, suppose the pair  $(\underline{x}, f) : p \oplus q \oplus m \rightarrow q \oplus p \oplus n$  with  $\underline{x} : r \rightarrow s$  is given. Then

$$\begin{aligned} \uparrow^{p \oplus q} [(\underline{x}, f) \cdot_{R(q,p,n)} (213)] &= (\underline{x}, \uparrow^{p \oplus q} [f \cdot_{R(q,p,n,r)} (2134)]) \text{definition } \uparrow, \cdot_R \\ &= (\underline{x}, \uparrow^{p \oplus q} [f \cdot_{R(q,p,n \oplus r)} (213)]) \text{REFINE} \\ &= (\underline{x}, \uparrow^{q \oplus p} [(213) \cdot_{L(q,p,m \oplus s)} f]) \text{LR9 in } T \\ &= \uparrow^{q \oplus p} [(213) \cdot_{L(p,q,m)} (\underline{x}, f)] \end{aligned}$$

C1 clearly holds. For R-REFINE we take  $(\underline{x}, f) : m \rightarrow n$  with  $\underline{x} : r \rightarrow s$  and  $n = n_1 \oplus \dots \oplus (n_i^1 \oplus \dots \oplus n_i^l) \oplus \dots \oplus n_k$ . Then

$$\begin{aligned} (\underline{x}, f) \cdot_{R(n_1, \dots, n_i^1 \oplus \dots \oplus n_i^l, \text{dots}, n_k)} \phi &= (\underline{x}, f \cdot_{R(n_1, \dots, n_i^1 \oplus \dots \oplus n_i^l, \text{dots}, n_k, s)} (\phi \oplus \mathbb{1}_1)) \\ &= (\underline{x}, f \cdot_{R(n_1, \dots, n_i^1, \dots, n_i^l, \text{dots}, n_k, s)} ((\phi(1)_1 \dots \phi(i)_l \dots \phi(k)_1) \oplus \mathbb{1}_1)) \\ &= (\underline{x}, f) \cdot_{R(n_1, \dots, n_i^1, \dots, n_i^l, \text{dots}, n_k)} (\phi(1)_1 \dots \phi(i)_l \dots \phi(k)_1) \end{aligned}$$

Finally, L-REFINE is similar.  $\square$

**Lemma 5.16** *Axiom LR6 holds in  $\text{NF}\ell[X, T] / \Rightarrow_{Tr}$ .*

**Proof:** Suppose we are given the pairs  $(\underline{x}, f) : m \rightarrow n$  with  $\underline{x} = x_1 \oplus \dots \oplus x_k : r \rightarrow s$  and  $(\underline{x}', f') : m' \rightarrow n'$  with  $\underline{x}' = x'_1 \oplus \dots \oplus x'_{k'} : r' \rightarrow s'$ . Then

$$\begin{aligned}
(21) \cdot_{L(m',m)} [(\underline{x}', f') \oplus (\underline{x}, f)] \cdot_{R(n',n)} (21) \\
&= (\underline{x}' \oplus \underline{x}, (3124) \cdot_{L(m',s',m,s)} (f' \oplus f) \cdot_{R(n',r',n,r)} (2314)) \\
&=: (\underline{x}' \oplus \underline{x}, g)
\end{aligned}$$

We show this resulting pair is similar via a block transposition with

$$\begin{aligned}
(\underline{x}, f) \oplus (\underline{x}', f') \\
&= (\underline{x} \oplus \underline{x}', (1324) \cdot_{L(m,s,m',s')} (f \oplus f') \cdot_{R(n,r,n',r')} (1324)) \\
&=: (\underline{x} \oplus \underline{x}', h)
\end{aligned}$$

More precisely, we show that

$$(\underline{x}' \oplus \underline{x}, g) \xrightarrow{Tr[(1,\dots,k') \leftrightarrow (k' \oplus 1, \dots, k' \oplus k)]} (\underline{x} \oplus \underline{x}', h)$$

Condition (i) in the definition of simulation clearly holds. We check (ii):

$$\begin{aligned}
(1243) \cdot_{L(m,m',s',s)} g \cdot_{R(n,n',r',r)} (1243) \\
&= (3142) \cdot_{L(m',s',m,s)} (f' \oplus f) \cdot_{R(n',r',n,r)} (2143) \\
&= (1324) \cdot_{L(m,s,m',s')} (f \oplus f') \cdot_{R(n,r,n',r')} (1324) \\
&= h
\end{aligned}$$

□

From the two lemmas above we get the following theorem.

**Theorem 5.17** *If  $T$  is an  $a\alpha$ -flow, then  $\mathbb{F}\ell_{a\alpha}[X, T]$  is an  $a\alpha$ -flow, too. □*

## 5.2.4 General composition on normal form expressions

We finish this section by completing the table of operations in  $\text{NF}\ell[X, T]$ . For  $(\underline{x}, f) : m \oplus p \rightarrow n \oplus p$  with  $\underline{x} : r \rightarrow s$  we have

$$\begin{aligned}
(\underline{x}, f) \uparrow^p &= \uparrow^p [(21) \cdot_{L(m,p)} (\underline{x}, f) \cdot_{R(n,p)} (21)] \\
&= (\underline{x}, \uparrow^p [(213) \cdot_{L(m,p,s)} f \cdot_{R(n,p,r)} (213)]) \\
&= (\underline{x}, [(21) \cdot_{L(p,m \oplus s)} [(213) \cdot_{L(m,p,s)} f \cdot_{R(n,p,r)} (213)] \cdot_{R(p,n \oplus r)} (21)] \uparrow^p) \\
&= (\underline{x}, [(132) \cdot_{L(m,p,s)} f \cdot_{R(n,p,r)} (132)] \uparrow^p)
\end{aligned}$$

Consequently, the following identity holds:

- **Right Feedback in  $\text{NF}\ell[X, T]$ :** for  $(\underline{x}, f) : m \oplus p \rightarrow n \oplus p$  we have

$$(\underline{x}, f) \uparrow^p = (\underline{x}, [(\mathbb{1}_1 \oplus \mathbb{1}^{\mathbb{X}^1}) \cdot_{L(m,p,o(\underline{x}))} f \cdot_{R(n,p,i(\underline{x}))} (\mathbb{1}_1 \oplus \mathbb{1}^{\mathbb{X}^1})] \uparrow^p)$$

For composition, if  $(\underline{x}, f) : m \rightarrow n$  with  $\underline{x} : r \rightarrow s$  and  $(\underline{x}', f') : n \rightarrow p$  with  $\underline{x}' : r' \rightarrow s'$ , then by using the above identity for “ $\_ \uparrow^n$ ” we get

$$\begin{aligned} (\underline{x}, f) \cdot (\underline{x}', f') &= [((\underline{x}, f) \oplus (\underline{x}', f')) \cdot_{R(n,p)} (21)] \uparrow^n \\ &= (\underline{x} \oplus \underline{x}', g) \end{aligned}$$

where

$$\begin{aligned} g &= [(1243) \cdot_{L(m,s,n,s')} (f \oplus f') \cdot_{R(n,r,p,r')} (4213)] \uparrow^n \\ &= [(f \oplus |_{s' \oplus n}) \cdot (|_{n \oplus r} \oplus s' \mathbf{X}^n \cdot f') \cdot (4_n 2_r 1_p 3_{r'})] \uparrow^n \\ &= (f \oplus |_{s'}) \cdot [(|_{n \oplus r} \oplus s' \mathbf{X}^n) \cdot {}^n \mathbf{X}^{r \oplus n \oplus s'} \cdot (|_r \oplus f' \oplus |_n) \cdot {}^{r \oplus p \oplus r'} \mathbf{X}^n \cdot (4_n 2_r 1_p 3_{r'})] \uparrow^n \\ &= (f \oplus |_{s'}) \cdot [(4_n 1_r 3_{s'} 2_n) \cdot (|_r \oplus f' \oplus |_n) \cdot (2_r 1_p 3_{r'} 4_n)] \uparrow^n \\ &= (f \oplus |_{s'}) \cdot [(4_n 1_r 3_{s'} 2_n) \cdot ((|_r \oplus f') \cdot (2_r 1_p 3_{r'}) \oplus |_n)] \uparrow^n \\ &= (f \oplus |_{s'}) \cdot (4_n 1_r 3_{s'} 2_n) \uparrow^n \cdot (|_r \oplus f') \cdot (2_r 1_p 3_{r'}) \\ &= (f \oplus |_{s'}) \cdot (2_n 1_r 3_{s'}) \cdot {}^r \mathbf{X}^{n \oplus s'} \cdot (f' \oplus |_r) \cdot {}^{p \oplus r'} \mathbf{X}^r \cdot (2_r 1_p 3_{r'}) \\ &= (f \oplus |_{s'}) \cdot (|_n \oplus {}^r \mathbf{X}^{s'}) \cdot (f' \oplus |_r) \cdot (|_p \oplus {}^{r'} \mathbf{X}^r) \end{aligned}$$

So, we have found the following identity

- **Composition in  $\text{INF}\ell[X, T]$ :** for  $(\underline{x}, f) : m \rightarrow n$  and  $(\underline{x}', f') : n \rightarrow p$  we have

$$(\underline{x}, f) \cdot (\underline{x}', f') = (\underline{x} \oplus \underline{x}', (f \oplus |_{o(\underline{x}')})) \cdot (|_n \oplus {}^{i(\underline{x})} \mathbf{X}^{o(\underline{x}')})) \cdot (f' \oplus |_{i(\underline{x})}) \cdot (|_p \oplus {}^{i(\underline{x}')} \mathbf{X}^{i(\underline{x})})$$

### 5.2.5 Example of computation using normal forms

The proof of the equality in Example 4.6 was made using the rules of  $a\alpha$ -flow in an ad-hoc way. However, the equality of  $a\alpha$ -flownomilas may be checked using a simple decision procedure based on the normal forms. It consists in two steps:

- bring each expression to the normal form
- check whether the resulting normal forms are isomorphic (= similar via transpositions)

Below we show how this method may be applied to check the equality in Example 4.6. In this example the connections are made with elements in  $\text{Pfn}^{-1}$  (converses of partial functions). We represent such an element

$$(\phi^{-1}(1) \dots \phi^{-1}(n))$$

where  $\phi^{-1}(i) = \perp$  when  $\phi^{-1}(i)$  is undefined.

**Example 5.18**  $\wedge_2^b \cdot (|_b \oplus (x \cdot \wedge_2^a)) \uparrow^a \cdot f$

- $x = (x, (3_a 1_b 2_a)) : b \oplus a \rightarrow a$
- $x \cdot \wedge_2^a = (x, (3_a 3_a 1_b 2_a)) : b \oplus a \rightarrow 2a$
- $(x \cdot \wedge_2^a) \uparrow^a = (x, (2_a 1_b 2_a)) : b \rightarrow a$



- $l_b \oplus (x \cdot \wedge_2^a) \uparrow^a = (x, (1_b 3_a 2_b 3_a)) : b \oplus b \rightarrow b \oplus a$
- $\wedge_2^b \cdot (l_b \oplus (x \cdot \wedge_2^a) \uparrow^a) = (x, (1_b 2_a 1_b 2_a)) : b \rightarrow b \oplus a$
- $[\wedge_2^b \cdot (l_b \oplus (x \cdot \wedge_2^a) \uparrow^a)] \cdot x$   
 $= (x \oplus x, (1_b 2_a 1_b 2_a 3_a)) \cdot (1_b 2_a 5_a 3_b 4_a) \cdot (3_a 1_b 2_a 4_b 5_a) \cdot (1_a 4_b 5_a 2_b 3_a)$   
 $= (x \oplus x, (3_a 1_b 2_a 1_b 2_a)) : b \rightarrow a$

$$[\wedge_2^{b \oplus a} \cdot (x \oplus x)] \uparrow^a$$

- $x = (x, (3_a 1_b 2_a)) : b \oplus a \rightarrow a$
- $x \oplus x = (x \oplus x, (5_a 6_a 1_b 2_a 3_b 4_a)) : 2(b \oplus a) \rightarrow 2a$
- $\wedge_2^{b \oplus a} \cdot (x \oplus x) = (x \oplus x, (3_a 4_a 1_b 2_a 1_b 2_a)) : b \oplus a \rightarrow 2a$
- $(\wedge_2^{b \oplus a} \cdot (x \oplus x)) \uparrow^a = (x \oplus x, (2_a 1_b 3_a 1_b 3_a)) : b \rightarrow a$

They are similar, namely

$$(l_b \oplus {}^a X^a) \cdot (2_a 1_b 3_a 1_b 3_a) = (3_a 1_b 2_a 1_b 2_a) \cdot (l_a \oplus {}^{b \oplus a} X^{b \oplus a})$$

Indeed,

$$(1_b 3_a 2_a) \cdot (2_a 1_b 3_a 1_b 3_a) = (3_a 1_b 2_a 1_b 2_a) = (3_a 1_b 2_a 1_b 2_a) \cdot (1_a 4_b 5_a 2_b 3_a)$$

□

## 5.3 Completeness of $a\alpha$ -Flow-Calculus

The above analysis has shown that a concrete flowgraph may be represented by an AC-pair (or equivalently, by a normal form flownomial expression) unique up to a chain of simulations via transpositions. In order to prove that the rules of  $a\alpha$ -Flow-Calculus are complete in the sense of Fact 2.(ii) in Section B.2.3, one has to show that :

- every expression may be brought to a normal form using rules that are deductible from  $R0_T + R1-R9 + EqL$ ;
- simulation via transpositions is a rule deductible from  $R0_T + R1-R9 + EqL$ .

These proofs are given in this section in the abstract setting, namely when the support theory is an arbitrary  $a\alpha$ -flow.

### 5.3.1 Bringing expressions to normal form

**Definition 5.19** (normal form expressions; — general case)

The definition of the normal form expressions in the sets  $\mathbb{F}\ell_{EXP}[X, T](m, n)$  is the same as in the case  $T \subseteq \mathbb{R}el$  given above, namely are those expressions of the form

$$[(l_m \oplus x_1 \oplus \dots \oplus x_k) \cdot n(f)] \uparrow^{i(x_1) \oplus \dots \oplus i(x_k)}$$

where  $x_1, \dots, x_k$  are variables in  $X$  and  $f \in T(m \oplus o(x_1) \oplus \dots \oplus o(x_k), n \oplus i(x_1) \oplus \dots \oplus i(x_k))$ . Here we have made a distinction between a morphism  $f$  in the support theory  $T$  and the corresponding expression  $n(f)$  in  $\mathbb{F}\ell_{EXP}[X, T]$ . □

Table 5.2: Rules for bringing an expression  $f$  in  $\mathbb{F}\ell_{EXP}[X, T]$  to a normal form  $\text{nf}(f)$

NF1	for $f \in T(m, n)$
	$\text{nf}(f) = (l_m \cdot n(f)) \uparrow^0$
NF2	for $x \in X(m, n)$
	$\text{nf}(x) = [(l_m \oplus x) \cdot n({}^m X^n)] \uparrow^m$
<p>In the following rules NF3–NF5, <math>\underline{x}</math>, <math>o(\underline{x})</math>, <math>\underline{x}'</math>, etc. will denote <math>x_1 \oplus \dots \oplus x_k</math>, <math>o(x_1) \oplus \dots \oplus o(x_k)</math>, <math>x'_1 \oplus \dots \oplus x'_{k'}</math>, etc., respectively.</p>	
NF3	Denote $g = (l_m \oplus {}^p X^{o(\underline{x})} \oplus l_{o(\underline{x}')} ) \cdot (f \oplus f') \cdot (l_n \oplus {}^{i(\underline{x})} X^p \oplus l_{i(\underline{x}')} )$ . Then
	$\text{nf}([(l_m \oplus \underline{x}) \cdot n(f)] \uparrow^{i(\underline{x})} \oplus [(l_p \oplus \underline{x}') \cdot n(f')] \uparrow^{i(\underline{x}')}] = [(l_{m \oplus p} \oplus \underline{x} \oplus \underline{x}') \cdot n(g)] \uparrow^{i(\underline{x}) \oplus i(\underline{x}')}$
NF4	Denote $g = (f \oplus l_{o(\underline{x}')} ) \cdot (l_n \oplus {}^{i(\underline{x})} X^{o(\underline{x}')}) \cdot (f' \oplus l_{i(\underline{x})}) \cdot (l_p \oplus {}^{i(\underline{x}')} X^{i(\underline{x})})$ . Then
	$\text{nf}([(l_m \oplus \underline{x}) \cdot n(f)] \uparrow^{i(\underline{x})} \cdot [(l_n \oplus \underline{x}') \cdot n(f')] \uparrow^{i(\underline{x}')}] = [(l_m \oplus \underline{x} \oplus \underline{x}') \cdot n(g)] \uparrow^{i(\underline{x}) \oplus i(\underline{x}')}$
NF5	Denote $g = [(l_m \oplus {}^{o(\underline{x})} X^p) \cdot f \cdot (l_n \oplus {}^p X^{i(\underline{x})})$ . Then
	$\text{nf}([(l_{m \oplus p} \oplus \underline{x}) \cdot n(f)] \uparrow^{i(\underline{x}) \uparrow^p}) = [(l_m \oplus \underline{x}) \cdot n(g)] \uparrow^{i(\underline{x})}$

In this subsection we prove that every expression may be brought to a normal form by using the rules NF1–NF5 in Table 5.2.

It is obvious that the normal form expressions in  $\mathbb{F}\ell_{EXP}[X, T](m, n)$  and the AC-pairs in  $\text{NF}\ell[X, T](m, n)$  are in a bijective correspondence via the applications

$$\text{pair}([(l_m \oplus x_1 \oplus \dots \oplus x_k) \cdot n(f)] \uparrow^{i(x_1) \oplus \dots \oplus i(x_k)}) = (x_1 \oplus \dots \oplus x_k, f)$$

and

$$\text{exp}(x_1 \oplus \dots \oplus x_k, f) = [(l_m \oplus x_1 \oplus \dots \oplus x_k) \cdot n(f)] \uparrow^{i(x_1) \oplus \dots \oplus i(x_k)}$$

Since  $\mathbb{F}\ell_{EXP}[X, T]$  is an algebra freely generated by  $X$  and  $T$  there exists a unique morphism

$$\mathcal{E}_{\text{NF1}} : \mathbb{F}\ell_{EXP}[X, T] \rightarrow \text{NF}\ell[X, T]$$

introduced by the embedding  $(E_X, E_T)$  of  $(X, T)$  in  $\text{NF}\ell[X, T]$  defined in just above Lemma 5.12. First note that

**Lemma 5.20** *In  $\text{NF}\ell[X, T]$  the following identity holds*

$$[(l_m \oplus E_X(x_1) \oplus \dots \oplus E_X(x_k)) \cdot E_T(f)] \uparrow^{i(x_1) \oplus \dots \oplus i(x_k)} = (x_1 \oplus \dots \oplus x_k, f)$$

Table 5.3: The rule of simulation via transpositions

$\text{SIM}_{Tr} \quad [(l_m \oplus x_1 \oplus \dots \oplus x_k) \cdot n(f)] \uparrow^{i(x_1) \oplus \dots \oplus i(x_k)}$ $= [(l_m \oplus x'_1 \oplus \dots \oplus x'_k) \cdot n(f')] \uparrow^{i(x'_1) \oplus \dots \oplus i(x'_k)}$ <p style="margin: 0;">where <math>x_1, \dots, x_k</math> are from <math>X</math>, <math>f</math> is from <math>T</math>, and for a <math>t \in [k-1]</math>:</p> <p style="margin: 0;"><math>x'_i = x_i, \forall i \in [k] - \{t, t+1\}, x'_t = x_{t+1}, x'_{t+1} = x_t</math> and</p> $f' = (l_m \oplus l_{\Sigma_{j < t} o(x_j)} \oplus o(x_{t+1}) \mathbf{X}^{o(x_t)} \oplus l_{\Sigma_{j > t+1} o(x_j)})$ $\cdot f \cdot (l_n \oplus l_{\Sigma_{j < t} i(x_j)} \oplus i(x_t) \mathbf{X}^{i(x_{t+1})} \oplus l_{\Sigma_{j > t+1} i(x_j)})$
--

**Proof:** First prove by induction on  $k$  that

$$E_X(x_1) \oplus \dots \oplus E_X(x_k) = (x_1 \oplus \dots \oplus x_k, {}^r \mathbf{X}^s)$$

where  $r = i(x_1) \oplus \dots \oplus i(x_k)$  and  $s = o(x_1) \oplus \dots \oplus o(x_k)$ . Then one gets the identity

$$(l_m \oplus E_X(x_1) \oplus \dots \oplus E_X(x_k)) \cdot E_T(f) = (x_1 \oplus \dots \oplus x_k, (l_m \oplus {}^r \mathbf{X}^s) \cdot (f \oplus l_r))$$

Finally, apply (right) feedback  $\_ \uparrow^r$  to this equality. Then in the right hand side we get the pair  $(x_1 \oplus \dots \oplus x_k, f)$ .  $\square$

It follows that the application **pair** is the restriction of the evaluation morphism  $\mathcal{E}_{\text{INF1}}$  to the normal form expressions.

**Notation 5.21** ( $\equiv_{nf}$ )

The congruence relation generated in  $\mathbb{F}\ell_{EXP}[X, T]$  by the rules NF1–NF5 is denoted by  $\equiv_{nf}$ . (It is clearly equal to the relation generated by NF1–NF5+EqL.)  $\square$

**Proposition 5.22** *Every expression may be brought to a normal form by using the rules NF1–NF5+EqL.*

**Proof:** By structural induction, it is clear that every expression may be brought to a normal form by using (Equational Logic and) the rules NF1–NF5 from left to right.  $\square$

### 5.3.2 Simulation rule

The rule of simulation via transpositions  $\text{SIM}_{Tr}$  is given in Table 5.3. It shows how are related two normal form isomorphic expressions.

### 5.3.3 Deduction of the normalisation and simulation rules from the rules of $\alpha\alpha$ -Flow-Calculus

First we show that certain identities suggested by these rules hold in an  $\alpha\alpha$ -flow.

**Lemma 5.23** *The following identities hold in an  $\alpha\alpha$ -flow.*

$$\text{Nf1 } f = (l_m \cdot f) \uparrow^0 \text{ for } f : m \rightarrow n$$

$$\text{Nf2 } f = ((l_m \oplus f) \cdot {}^m\mathbf{X}^n) \uparrow^m \text{ for } f : m \rightarrow n$$

$$\text{Nf3 } \text{for } g : r \rightarrow s, f : m \oplus s \rightarrow n \oplus r, g' : r' \rightarrow s' \text{ and } f' : p \oplus s' \rightarrow q \oplus r'$$

$$\begin{aligned} & [(l_m \oplus g) \cdot f] \uparrow^r \oplus [(l_p \oplus g') \cdot f'] \uparrow^{r'} \\ &= [(l_{m \oplus p} \oplus g \oplus g') \cdot (l_m \oplus {}^p\mathbf{X}^s \oplus l_{s'}) \cdot (f \oplus f') \cdot (l_n \oplus {}^r\mathbf{X}^q \oplus l_{r'})] \uparrow^{r \oplus r'} \end{aligned}$$

$$\text{Nf4 } \text{for } g : r \rightarrow s, f : m \oplus s \rightarrow n \oplus r, g' : r' \rightarrow s' \text{ and } f' : n \oplus s' \rightarrow p \oplus r'$$

$$\begin{aligned} & [(l_m \oplus g) \cdot f] \uparrow^r \cdot [(l_p \oplus g') \cdot f'] \uparrow^{r'} \\ &= [(l_m \oplus g \oplus g') \cdot (f \oplus l_{s'}) \cdot (l_n \oplus {}^r\mathbf{X}^s) \cdot (f' \oplus l_r) \cdot (l_p \oplus {}^{r'}\mathbf{X}^r)] \uparrow^{r \oplus r'} \end{aligned}$$

$$\text{Nf5 } \text{for } g : r \rightarrow s \text{ and } f : m \oplus p \oplus s \rightarrow n \oplus p \oplus r,$$

$$([(l_{m \oplus p} \oplus g) \cdot f] \uparrow^r) \uparrow^p = [(l_m \oplus g) \cdot ((l_m \oplus {}^s\mathbf{X}^p) \cdot f \cdot (l_n \oplus {}^p\mathbf{X}^r)) \uparrow^p] \uparrow^r$$

$$\text{Sim}_{Tr} \text{ for } f : m \oplus s_1 \oplus s_2 \oplus s_3 \oplus s_4 \rightarrow n \oplus r_1 \oplus r_2 \oplus r_3 \oplus r_4 \text{ and } g_j : r_j \rightarrow s_j \quad \forall j \in [4]$$

$$\begin{aligned} & [(l_m \oplus g_1 \oplus g_2 \oplus g_3 \oplus g_4) \cdot f] \uparrow^{r_1 \oplus r_2 \oplus r_3 \oplus r_4} \\ &= [(l_m \oplus g_1 \oplus g_3 \oplus g_2 \oplus g_4) \cdot (l_{m \oplus s_1} \oplus {}^{s_3}\mathbf{X}^{s_2} \oplus l_{s_4}) \cdot f \cdot (l_{m \oplus r_1} \oplus {}^{r_2}\mathbf{X}^{r_3} \oplus l_{r_4})] \uparrow^{r_1 \oplus r_3 \oplus r_2 \oplus r_4} \end{aligned}$$

**Proof:** First of all we recall that the following identities hold in an  $\alpha\alpha$ -flow

$$\text{R6}' (f \oplus g) \cdot {}^p\mathbf{X}^q = {}^m\mathbf{X}^n \cdot (g \oplus f) \text{ for } f : m \rightarrow p, g : n \rightarrow q \text{ and}$$

$$\text{R8}' f \uparrow^p \oplus g = [(l_m \oplus {}^{m'}\mathbf{X}^p) \cdot (f \oplus g) \cdot (l_n \oplus {}^p\mathbf{X}^{n'})] \uparrow^p \text{ for } f : m \oplus p \rightarrow n \oplus p, g : m' \rightarrow n'.$$

The first identity Nf1 follows from SV1.

For Nf2 note that

$$\begin{aligned} [(l_m \oplus f) \cdot {}^m\mathbf{X}^n] \uparrow^m &= [{}^m\mathbf{X}^m \cdot (f \oplus l_m)] \uparrow^m && \text{by R6}' \\ &= ({}^m\mathbf{X}^m) \uparrow^m \cdot f && \text{by R7} \\ &= l_m \cdot f && \text{by C5} \\ &= f \end{aligned}$$

Nf3 may be proved as follows

$$\begin{aligned} & [(l_m \oplus g)f] \uparrow^r \oplus [(l_p \oplus g')f'] \uparrow^{r'} \\ &= [(l_m \oplus {}^p\mathbf{X}^r) [(l_m \oplus g)f \oplus (l_p \oplus g')f'] \uparrow^{r'} \cdot (l_n \oplus {}^r\mathbf{X}^q)] \uparrow^r && \text{R8}', \text{ then R8} \\ &= [(l_m \oplus {}^p\mathbf{X}^r \oplus l_{r'}) ((l_m \oplus g)f \oplus (l_p \oplus g')f') (l_n \oplus {}^r\mathbf{X}^q \oplus l_{r'})] \uparrow^{r'} \uparrow^r && \text{R7} \\ &= [(l_m \oplus {}^p\mathbf{X}^r \cdot (g \oplus l_p) \oplus g') (f \oplus f') (l_n \oplus {}^r\mathbf{X}^q \oplus l_{r'})] \uparrow^{r \oplus r'} && \text{R5} \\ &= [(l_m \oplus l_p \oplus g \oplus g') (l_m \oplus {}^p\mathbf{X}^s \oplus l_{s'}) (f \oplus f') (l_n \oplus {}^r\mathbf{X}^q \oplus l_{r'})] \uparrow^{r \oplus r'} && \text{R6}', \text{R7} \end{aligned}$$

Nf4 may be proved as follows

$$\begin{aligned}
& [(l_m \oplus g) f] \uparrow^r \cdot [(l_p \oplus g') f'] \uparrow^{r'} \\
&= [((l_m \oplus g) f) \uparrow^r \oplus l_{r'}] \cdot (l_n \oplus g') f'] \uparrow^{r'} && \text{by R7} \\
&= [((l_m \oplus {}^{r'}\mathbf{X}^r) ((l_m \oplus g) f \oplus l_{r'}) (l_n \oplus {}^r\mathbf{X}^{r'}))] \uparrow^r \cdot (l_n \oplus g') f'] \uparrow^r \uparrow^{r'} && \text{by R8'} \\
&= [(l_m \oplus {}^{r'}\mathbf{X}^r) ((l_m \oplus g) f \oplus l_{r'}) (l_n \oplus {}^r\mathbf{X}^{r'}) ((l_n \oplus g') f' \oplus l_r)] \uparrow^{r'} && \text{by R7} \\
&= [(l_m \oplus {}^{r'}\mathbf{X}^r) ((l_m \oplus g) f \oplus l_{r'}) (l_n \oplus {}^r\mathbf{X}^{r'} (g' \oplus l_r)) (f' \oplus l_r)] \uparrow^{r' \oplus r} && \text{by R5} \\
&= [(l_m \oplus {}^{r'}\mathbf{X}^r) ((l_m \oplus g) f \oplus l_{r'}) (l_n \oplus (l_r \oplus g') {}^r\mathbf{X}^{s'}) (f' \oplus l_r)] \uparrow^{r' \oplus r} && \text{by R6'} \\
&= [(l_m \oplus {}^{r'}\mathbf{X}^r) (l_m \oplus g \oplus g') (f \oplus l_{r'}) (l_n \oplus {}^r\mathbf{X}^{s'}) (f' \oplus l_r)] \uparrow^{r' \oplus r} && \text{by R5} \\
&= [(l_m \oplus g \oplus g') (f \oplus l_{s'}) (l_n \oplus {}^r\mathbf{X}^{s'}) (f' \oplus l_r) (l_p \oplus {}^{r'}\mathbf{X}^r)] \uparrow^{r \oplus r'} && \text{by R9}
\end{aligned}$$

Before Nf5 we prove  $\text{Sim}_{Tr}$ .

$$\begin{aligned}
& [(l_m \oplus g_1 \oplus g_3 \oplus g_2 \oplus g_4) (l_{m \oplus s_1} \oplus {}^{s_3}\mathbf{X}^{s_2} \oplus l_{s_4}) \cdot f \cdot (l_{n \oplus r_1} \oplus {}^{r_2}\mathbf{X}^{r_3} \oplus l_{r_4})] \uparrow^{r_1 \oplus r_3 \oplus r_2 \oplus r_4} \\
&= [(l_{m \oplus r_1} \oplus {}^{r_3}\mathbf{X}^{r_2} \oplus l_{r_4}) (l_m \oplus g_1 \oplus g_2 \oplus g_3 \oplus g_4) \cdot f \cdot (l_{n \oplus r_1} \oplus {}^{r_2}\mathbf{X}^{r_3} \oplus l_{r_4})] \uparrow^{r_1 \oplus r_3 \oplus r_2 \oplus r_4} \\
&= [(l_m \oplus g_1 \oplus g_2 \oplus g_3 \oplus g_4) \cdot f \cdot (l_{n \oplus r_1} \oplus {}^{r_2}\mathbf{X}^{r_3} \oplus l_{r_4}) \cdot (l_{n \oplus r_1} \oplus {}^{r_3}\mathbf{X}^{r_2} \oplus l_{r_4})] \uparrow^{r_1 \oplus r_2 \oplus r_3 \oplus r_4} \\
&= [(l_m \oplus g_1 \oplus g_2 \oplus g_3 \oplus g_4) \cdot f] \uparrow^{r_1 \oplus r_2 \oplus r_3 \oplus r_4}
\end{aligned}$$

Finally, note that Nf5 follows from a particular instance of  $\text{Sim}_{Tr}$ , — namely that when  $g_1 = g_4 = l_0$  and  $g_2 = l_p$  — by applying rule R7.  $\square$

From this lemma we get the following result.

**Proposition 5.24** *The rules NF1–NF5+SIM<sub>Tr</sub> are deductible from R0<sub>T</sub>+R1–R9+EqL.*  
 $\square$

**Proposition 5.25** *(uniqueness of the normal form)*

*Different normal form expressions are not equivalent via the rules NF1–NF5+EqL.*

**Proof:** Suppose we are given two n.f. expressions

$$\begin{aligned}
E &= [(l_m \oplus \underline{x}) \cdot n(f)] \uparrow^{i(\underline{x})} \text{ with } \underline{x} = x_1 \oplus \dots \oplus x_k \quad \text{and} \\
E' &= [(l_m \oplus \underline{x}') \cdot n(f')] \uparrow^{i(\underline{x}')} \text{ with } \underline{x}' = x'_1 \oplus \dots \oplus x'_{k'}
\end{aligned}$$

that are equivalent via NF1–NF5+EqL. Then there exists a chain of expressions  $E_1, \dots$  such that

$$E \equiv_{nf} E_1 \equiv_{nf} \dots \equiv_{nf} E'$$

where at each step only one rule has been applied. From the definition of the operations in  $\text{NF}\ell[X, T]$  given in the previous section it follows that the rules NF1–NF5 hold in  $\text{NF}\ell[X, T]$ , hence we get a chain of equal pairs

$$\mathcal{E}_{\text{NF}\ell}(E) = \mathcal{E}_{\text{NF}\ell}(E_1) = \dots = \mathcal{E}_{\text{NF}\ell}(E')$$

This shows that

$$(x_1 \oplus \dots \oplus x_k, f) = (x'_1 \oplus \dots \oplus x'_{k'}, f')$$

hence  $k = k'$  and  $\forall j \in [k]: x_j = x'_j$ , and  $f = f'$ . This means,

$$E = E'$$

□

The normal form expression corresponding to an expression  $E$  actually is  $\text{EXP}(\mathcal{E}_{\text{NF1}}(E))$ . The argument for uniqueness in the above proof may also be presented as follows:

It is well known that the quotient algebra  $\mathbb{F}\ell_{\text{EXP}}[X, T] / \equiv_{nf}$  is a free model for the rules NF1–NF5. By the definition of the operations in  $\text{NF}\ell[X, T]$  given in the previous section,  $\text{NF}\ell[X, T]$  is a model for the rules NF1–NF5, too. Since two different n.f. expressions are interpreted as different elements in  $\text{NF}\ell[X, T]$  they must be different in the free model  $\mathbb{F}\ell_{\text{EXP}}[X, T] / \equiv_{nf}$ , too, hence they can not be  $\equiv_{nf}$ -equivalent.

### 5.3.4 Completeness of the axiom system

We collect the result of this chapter to prove the following completeness theorem.

**Theorem 5.26** (*completeness of the rules of  $a\alpha$ -Flow-Calculus*)

*If two expressions represent the same abstract directed flowgraph,<sup>4</sup> then they may be proved equivalent by using the rules  $R0_T + R1 - R9 + \text{EqL}$ .*

**Proof:** Proposition 5.22 shows an expression  $E$  may be brought to the normal form  $\text{nf}(E)$  using the rules NF1–NF5+EqL. By Proposition 5.24 these rules are deductible from  $R0_T + R1 - R9 + \text{EqL}$ . Using the correctness result (Theorem 5.17) it follows that the resulting normal form  $\text{nf}(E)$  and the given expression  $E$  represent the same elements in  $\mathbb{F}\ell_{a\alpha}[X, T]$ .

Now suppose we are given two expressions  $E$  and  $E'$  representing the same abstract directed flowgraph  $S$ . By the above argument the corresponding n.f. expressions  $\text{nf}(E)$  and  $\text{nf}(E')$  also represent  $S$ . By Proposition 5.4 (in the concrete case) or Definition 5.6 (in the abstract one) there is a chain of simulations via transpositions connecting  $\text{nf}(E)$  and  $\text{nf}(E')$ . The same Proposition 5.24 guarantees that the simulation rule is deductible from  $R0_T + R1 - R9 + \text{EqL}$ . Hence we have connected the expressions  $E$  and  $E'$  by rules deductible from  $R0_T + R1 - R9 + \text{EqL}$ . □

## 5.4 Meaning and universality of $a\alpha$ -flownomials

Let  $X$  be a set of doubly-ranked variables and  $T$  an  $a\alpha$ -flow whose elements are used to connect the variables in order to built up flowgraphs.

**Theorem 5.27** (*meaning of  $a\alpha$ -flownomials*)

*The algebras  $\mathbb{F}\ell_{a\alpha}[X, T]$  ( $= \text{NF}\ell[X, T] / \Rightarrow_{Tr}$ ) and  $\mathbb{F}\ell_{\text{EXP}}[X, T] / \sim_{a\alpha}$  are isomorphic. Hence  $a\alpha$ -flownomials over  $X$  and  $T$  may be identified to the abstract flowgraphs built up with atoms in  $X$  and connections in  $T$ .*

**Proof:** By Theorem 5.17 the rule  $R0_T + R1 - R9 + \text{EqL}$  hold in  $\text{NF}\ell[X, T] / \Rightarrow_{Tr}$ . Hence the evaluation morphism

$$\mathcal{E}_{\text{NF}\ell} : \mathbb{F}\ell_{\text{EXP}}[X, T] \rightarrow \text{NF}\ell[X, T] / \Rightarrow_{Tr}$$

---

<sup>4</sup>We recall, this means they have the same evaluation in the formal model  $\mathbb{F}\ell_{a\alpha}[X, T]$

induces one morphism at the level of  $a\alpha$ -flownomials, i.e.

$$\mathcal{E}_{\mathbb{F}\ell}^{a\alpha} : \mathbb{F}\ell_{EXP}[X, T] / \sim_{a\alpha} \rightarrow \mathbb{NF}\ell[X, T] / \Rightarrow_{Tr}$$

Obviously,  $\mathcal{E}_{\mathbb{F}\ell}^{a\alpha}$  is a surjective morphism. On the other hand, Theorem 5.26 asserts that two expressions that have the same evaluation in  $\mathbb{NF}\ell[X, T] / \Rightarrow_{Tr}$  are  $\sim_{a\alpha}$  equivalent. Consequently,  $\mathcal{E}_{\mathbb{F}\ell}^{a\alpha}$  is also an injective morphism, hence it is an isomorphism.  $\square$

The construction of the quotient algebra  $\mathbb{F}\ell_{EXP}[X, T] / \sim_{a\alpha}$  is the standard construction of the free algebra generated by the rules R1–R9 and R0<sub>T</sub>. So that the following universal property of  $a\alpha$ -flownomials is obvious.<sup>5</sup>

**Theorem 5.28** (*universal property of  $a\alpha$ -flownomials / abstract flowgraphs*)

*Let  $M$  be a monoid and  $T$  an  $M$ - $a\alpha$ -flow algebra. Then:*

- (i)  $\mathbb{F}\ell_{a\alpha}[X, T]$  is an  $M$ - $a\alpha$ -flow, too.
- (ii) There is a natural embedding  $(I_X, I_T)$  of  $(X, T)$  in  $\mathbb{F}\ell_{a\alpha}[X, T]$ , where  $I_X$  is a function and  $I_T$  is a morphism of  $a\alpha$ -flow algebras such that for every  $S'$ -sorted  $a\alpha$ -flow algebra, function  $\phi_X$ , and morphism of  $a\alpha$ -flow algebras  $\phi_T$  there exists a unique morphism of  $a\alpha$ -flow algebras  $\phi^\sharp : \mathbb{F}\ell_{a\alpha}[X, T] \rightarrow Q$  such that  $I_T \cdot \phi^\sharp = \phi_T$  and  $I_X \cdot \phi^\sharp = \phi_X$ .  $\square$

Actually the above theorem shows that the  $a\alpha$ -flow  $\mathbb{F}\ell_{a\alpha}[X, T]$  is the direct sum of the  $a\alpha$ -flow  $T$  and the one freely generated by  $X$ .

We finish this chapter with a corollary of the above results and Theorem 4.11.

**Theorem 5.29** (*Kleene-like theorem for functions/relations computed by programs*)

*Suppose  $F$  is a set of known statements in  $\mathbb{P}\text{fn}(D)$  (resp.  $\mathbb{R}\text{el}(D)$ ), where  $D$  is the set of memory states. The set of functions (resp. relations) computed by the deterministic (resp. nondeterministic) programs built up with statements from  $F$  coincide with the set of functions (resp. relations) represented by flownomial expressions over  $F$  and  $\mathbb{P}\text{fn}$  (resp.  $\mathbb{R}\text{el}$ ).  $\square$*

## 5.5 Short comments and references

‘Abstract’ morphism for connecting flowgraphs are used in [CaU82] and in all of our subsequent papers on flowchart schemes and flownomials, see [Ste87a, Ste87b, CaS88a, CaS90a, CaS92].

This chapter follows Chapter B, sec. 3–6 of [Ste91]. The main result is based on a series of papers dealing with the algebraization of flowchart schemes, including [CaU82, BIEs85, Ste86/90, Bar87a, CaS88a, CaS90b].

With different sets of operators various algebras for flowgraphs appear in [Mil79, Parr87, CaS90b, CaS88b].

In the classical algebraic calculus for regular languages it is often the case that certain abstract semirings are used instead of the Boolean  $\{0, 1\}$  semiring, e.g. by using formal series with such coefficients.

---

<sup>5</sup>This property is similar to the universal property of the polynomials over a ring.

# Chapter 6

## Graph isomorphism with various constants

In this chapter we extend the axiomatisation for flowgraphs modulo isomorphism to the case where more constants for generating relations are present in the syntactic definition of the flownomial expressions.

Actually, our previous theorems on graph isomorphism are very general: they hold whenever we start with a  $a\alpha$ -flow as a theory for connections. Hence, in order to get correct and complete axiomatisations for the present flowgraphs we have to solve only one problem, namely to get axiomatisations for these relations as enriched  $a\alpha$ -flows.

The resulting algebraic structures are called *xy-ssmc's with feedback* and are axiomatised by the  $a\alpha$ -flow axioms, the *xy-ssmc* axioms and certain new axioms which show how the feedback acts on the constants.

### 6.1 Axiomatising relations with feedback

In this section we try to extend the presentations as initial algebras given in Prelude A for sixteen classes of finite relations, in order to include the feedback. From these only 9 classes are closed with respect to feedback, namely  $\mathbb{B}i$  (bijections),  $\mathbb{I}n$  (injections),  $\mathbb{I}n^{-1}$  (converses on injections),  $\mathbb{P}Sur$  (partial surjections),  $\mathbb{P}Sur^{-1}$  (converses of partial surjections),  $\mathbb{P}fn$  (partial functions),  $\mathbb{P}fn^{-1}$  (converses of partial functions), and  $\mathbb{R}el$  (relations), — see Figure 6.1.

The resulting algebras are  $a\alpha$ -flows over *xy-ssmc's* and such that the feedback acts on the additional constants as it is shown in Table 6.1.

Table 6.1: Axioms for the action of feedback on constants.

	FA $l_a \uparrow^a = l_0$	
	FB ${}^aX^a \uparrow^a = l_a$	
FC $\vee_a \uparrow^a = \perp^a$		FC <sup>o</sup> $\wedge^a \uparrow^a = \top_a$
	FD $[(l_a \oplus \wedge^a) \cdot ({}^aX^a \oplus l_a) \cdot (l_a \oplus \vee_a)] \uparrow^a = l_a$	



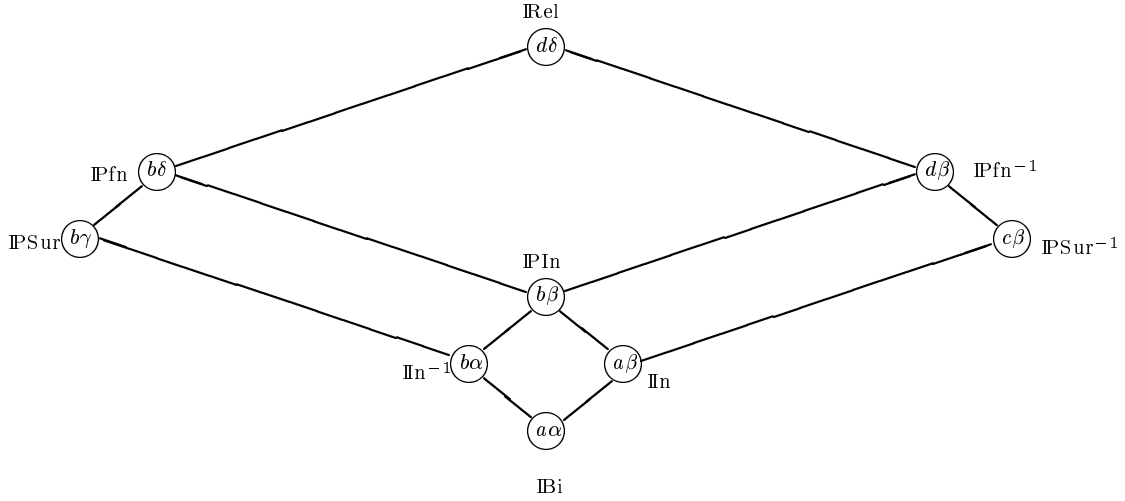

Figure 6.1: Relations closed to feedback

**Lemma 6.1** *Suppose  $xy$  is a restriction with  $x \in \{a, b, c, d\}$  and  $y \in \{\alpha, \beta, \gamma, \delta\}$ . Then  $xy\text{-Rel}_S$  is closed under feedback if and only if*

$$x = b \quad \text{or} \quad y = \beta \quad \text{or} \quad xy \in \{a\alpha, d\delta\}$$

**Proof:** In  $\text{Rel}_S$  for  $s \in S$  we have

$$\wedge^s \uparrow^s = \top_s \quad \text{and} \quad \vee_s \uparrow^s = \perp^s$$

Hence the classes  $xy\text{-Rel}_S$  with  $xy \in \{a\gamma, a\delta, c\alpha, c\gamma, c\delta, d\alpha, d\gamma\}$  are not closed under feedback. What remain are the cases in the statement of the lemma, and, in these cases, it is an easy task to verify the closure to feedback.  $\square$

**Definition 6.2** ( $xy\text{-ssmc}$  with feedback)

Suppose  $xy$  is a restriction such that  $x = b$  or  $y = \beta$  or  $xy \in \{a\alpha, d\delta\}$ .

A structure  $T$  is an  $xy\text{-ssmc}$  with feedback iff

- $T$  is an  $xy\text{-ssmc}$
- $T$  is an  $a\alpha$ -flow and
- the axioms in Table 6.1 corresponding to  $xy$  hold in  $T$ .<sup>1</sup>

A *morphism of  $xy\text{-ssmc}$ 's with feedback* is a morphism of  $xy\text{-ssmc}$ 's preserving the feedback operation.<sup>2</sup>  $\square$

<sup>1</sup>Since the validity of axioms FA and FB is included in the definition of an  $a\alpha$ -flow, the last condition means: axiom FC when  $xy \in \{b\gamma, b\delta, d\delta\}$ , axiom FC<sup>o</sup> when  $xy \in \{c\beta, d\beta, d\delta\}$ , and axiom FD when  $xy = d\delta$ .

<sup>2</sup>If  $h$  is the corresponding monoid morphism, then this condition is  $H(f \uparrow^a) = H(f) \uparrow^{h(a)}$ .

Let us note that in the case  $a\alpha$  the resulted structure of  $a\alpha$ -ssmc with feedback coincides with the structure of  $a\alpha$ -flow.

**Lemma 6.3** *Suppose  $xy$  is such that  $x = b$  or  $y = \beta$  or  $xy \in \{a\alpha, d\delta\}$ . Then:*

- (i) *The structure  $xy$ - $\mathbb{R}el_S$  with the natural feedback is an  $xy$ -ssmc with feedback.*
- (ii) *If  $B$  is an  $xy$ -ssmc with feedback and  $H : xy$ - $\mathbb{R}el_S \rightarrow B$  is a morphism of  $xy$ -ssmc's, then  $H$  commutes with the feedback operation.*

**Proof:** (i) It easily follows using Theorem 4.11.

(ii) Let  $f \in xy$ - $\mathbb{R}el_S(a \oplus s, b \oplus s)$  with  $s \in S$  be a relation written in the standard form

$$f = (\sum_{j \in [|a|]} \wedge_{m_j}^{a_j} \oplus \wedge_m^s) \cdot g \cdot (\sum_{i \in [|b|]} \vee_{b_i}^{n_i} \oplus \vee_s^n)$$

Using R7 in  $B$  and in  $xy$ - $\mathbb{R}el_S$  it follows that

$$H(f) \uparrow^{H(s)} = (\sum_{j \in [|a|]} \wedge_{m_j}^{H(a_j)}) \cdot H(h) \uparrow^{H(s)} \cdot (\sum_{i \in [|b|]} \vee_{H(b_i)}^{n_i})$$

and

$$H(f \uparrow^s) = (\sum_{j \in [|a|]} \wedge_{m_j}^{H(a_j)}) \cdot H(h \uparrow^s) \cdot (\sum_{i \in [|b|]} \vee_{H(b_i)}^{n_i})$$

where

$$h = (\downarrow_{\sum_{j \in [|a|]} m_j a_j} \oplus \wedge_m^s) \cdot g \cdot (\downarrow_{\sum_{i \in [|b|]} n_i b_i} \oplus \vee_s^n)$$

Since  $g$  obeys condition (iii) in Theorem 2.8. it is enough to prove the commutation with feedback only for

$$f = (\downarrow_a \oplus \wedge_m^s) \cdot g \cdot (\downarrow_b \oplus \vee_s^n)$$

where  $g \in \mathbb{B}i_S(a \oplus ms, b \oplus ns)$  and

$$(\top_a \oplus \downarrow_{ms}) \cdot g \cdot (\perp^b \oplus \downarrow_{ns}) \in \{\perp^{ms} \cdot \top_{ns}, \perp^{(m-1)s} \cdot \top_{(n-1)s} \oplus \downarrow_s\}$$

Now we prove the result by cases:

1. Case  $m = 0$  (when  $x \in \{b, d\}$ ):

$$\begin{aligned} H(f) \uparrow^{H(s)} &= [(\downarrow_{H(a)} \oplus \perp^{H(s)}) H(g) (\downarrow_{H(b)} \oplus \vee_{H(s)}^n)] \uparrow^{H(s)} \\ &= [H(g) (\downarrow_{H(b)} \oplus \vee_{H(s)}^n \cdot \perp^{H(s)})] \uparrow^0 && \text{R9} \\ &= H(g) (\downarrow_{H(b)} \oplus \perp^{nH(s)}) \\ &= H(g) (\downarrow_b \oplus \perp^{ns}) \\ &= H(f \uparrow^s) \end{aligned}$$

2. Case  $n = 0$  (when  $y \in \{\beta, \delta\}$ ): Dual with case 1.

3. Case  $m \geq 1$  and  $n \geq 1$ . There are two possibilities:

- (a) Case when  $(\top_a \oplus \mathbb{1}_{ms}) \cdot g \cdot (\perp^b \oplus \mathbb{1}_{ns}) = \perp^{ms} \cdot \top_{ns}$ . In this case there are  $c \in S^*$  and  $u \in \mathbb{B}i_S(a, c \oplus ns)$  and  $v \in \mathbb{B}i_S(c \oplus ms, b)$  such that

$$g = (u \oplus \mathbb{1}_{ms}) (\mathbb{1}_c \oplus {}^{ns}\mathbf{X}^{ms}) (v \oplus \mathbb{1}_{ns})$$

It follows that

$$\begin{aligned} f &= (u \oplus \wedge_m^s) (\mathbb{1}_c \oplus {}^{ns}\mathbf{X}^{ms}) (v \oplus \vee_s^n) \\ &= (u \oplus \mathbb{1}_s) [\mathbb{1}_c \oplus (\mathbb{1}_{ns} \oplus \wedge_m^s) \cdot {}^{ns}\mathbf{X}^{ms} \cdot (\mathbb{1}_{ms} \oplus \vee_s^n)] (v \oplus \mathbb{1}_s) \\ &= (u \oplus \mathbb{1}_s) [\mathbb{1}_c \oplus (\vee_s^n \oplus \mathbb{1}_s) \cdot {}^s\mathbf{X}^s \cdot (\wedge_m^s \oplus \mathbb{1}_s)] (v \oplus \mathbb{1}_s) \\ &= [u(\mathbb{1}_c \oplus \vee_s^n) \oplus \mathbb{1}_s] (\mathbb{1}_c \oplus {}^s\mathbf{X}^s) [(\mathbb{1}_c \oplus \wedge_m^s)v \oplus \mathbb{1}_s] \end{aligned}$$

hence

$$\begin{aligned} H(f) \uparrow^{H(s)} &= H(u(\mathbb{1}_c \oplus \vee_s^n)) \cdot [{}_{H(c)} \oplus {}^{H(s)}\mathbf{X}^{H(s)}] \uparrow^{H(s)} \cdot H((\mathbb{1}_c \oplus \wedge_m^s)v) \\ &= H(u(\mathbb{1}_c \oplus \vee_s^n) \cdot (\mathbb{1}_c \oplus \wedge_m^s)v) \quad \text{FB} \\ &= H(f \uparrow^s) \end{aligned}$$

- (b) Case when  $(\top_a \oplus \mathbb{1}_{ms}) \cdot g \cdot (\perp^b \oplus \mathbb{1}_{ns}) = \perp^{(m-1)s} \cdot \top_{(n-1)s} \oplus \mathbb{1}_s$ .

- i. Subcase  $m = 1$  or  $n = 1$ : First note that  $g = h \oplus \mathbb{1}_s$  with  $h \in \mathbb{B}i_S(a \oplus (m-1)s, b \oplus (n-1)s)$

- If  $m = 1$  and  $n = 1$ , then

$$\begin{aligned} H(f) \uparrow^{H(s)} &= H(h) \oplus {}_{H(s)} \uparrow^{H(s)} \\ &= H(h) \\ &= H(f \uparrow^s) \end{aligned}$$

- If  $m = 1$  and  $n > 1$  (case  $y \in \{\gamma, \delta\}$ ), then

$$\begin{aligned} f &= (h \oplus \mathbb{1}_s) \cdot (\mathbb{1}_b \oplus \vee_s^n) \\ &= (h (\mathbb{1}_b \oplus \vee_s^{n-1}) \oplus \mathbb{1}_s) \cdot (\mathbb{1}_b \oplus \vee_s) \end{aligned}$$

hence

$$\begin{aligned} H(f) \uparrow^{H(s)} &= H(h (\mathbb{1}_b \oplus \vee_s^{n-1})) \cdot ({}_{H(b)} \oplus \vee_{H(s)}) \uparrow^{H(s)} \\ &= H(h (\mathbb{1}_b \oplus \vee_s^{n-1})) \cdot ({}_{H(b)} \oplus \perp^{H(s)}) \quad \text{FC} \\ &= H(h (\mathbb{1}_b \oplus \vee_s^{n-1}) \cdot (\mathbb{1}_b \oplus \perp^s)) \\ &= H(f \uparrow^s) \end{aligned}$$

- If  $m > 1$  and  $n = 1$  (when  $x \in \{c, d\}$ ) the commutation follows by duality.

- ii. Subcase  $m > 1$  and  $n > 1$  (when  $xy = d\delta$ ). In this case there are  $c \in S^*$ ,  $u \in \mathbb{B}i_S(a, c \oplus (n-1)s)$  and  $v \in \mathbb{B}i_S(c \oplus (m-1)s, b)$  such that

$$g = (u \oplus \mathbb{1}_{ms}) \cdot (\mathbb{1}_c \oplus {}^{(n-1)s}\mathbf{X}^{(m-1)s} \oplus \mathbb{1}_s) \cdot (v \oplus \mathbb{1}_{ns})$$

It follows that

$$\begin{aligned} f &= (u \oplus \wedge_m^s) \cdot (\mathbb{1}_c \oplus {}^{(n-1)s}\mathbf{X}^{(m-1)s} \oplus \mathbb{1}_s) \cdot (v \oplus \vee_s^n) \\ &= (u \oplus \mathbb{1}_s) \cdot [\mathbb{1}_c \oplus (\mathbb{1}_{(n-1)s} \oplus \wedge^s (\wedge_{m-1}^s \oplus \mathbb{1}_s)) \cdot ({}^{(n-1)s}\mathbf{X}^{(m-1)s} \oplus \mathbb{1}_s) \\ &\quad \cdot (\mathbb{1}_{(m-1)s} \oplus (\vee_s^{n-1} \oplus \mathbb{1}_s) \vee_s)] \cdot (v \oplus \mathbb{1}_s) \\ &= (u \oplus \mathbb{1}_s) \cdot [\mathbb{1}_c \oplus (\vee_s^{n-1} \oplus \wedge^s) \cdot ({}^s\mathbf{X}^s \oplus \mathbb{1}_s) \cdot (\wedge_{m-1}^s \oplus \vee_s)] \cdot (v \oplus \mathbb{1}_s) \\ &= [u(\mathbb{1}_c \oplus \vee_s^{n-1}) \oplus \mathbb{1}_s] \cdot [\mathbb{1}_c \oplus (\mathbb{1}_s \oplus \wedge^s) ({}^s\mathbf{X}^s \oplus \mathbb{1}_s) (\mathbb{1}_s \oplus \vee_s)] \\ &\quad \cdot [(\mathbb{1}_c \oplus \wedge_{m-1}^s)v \oplus \mathbb{1}_s] \end{aligned}$$

hence

$$\begin{aligned}
& H(f) \uparrow^{H(s)} \\
&= H(u(l_c \oplus \vee_s^{n-1})) \cdot [ l_{H(c)} \oplus \\
&\quad \oplus ((l_{H(s)} \oplus \wedge^{H(s)}) \cdot ({}^{H(s)}\mathbf{X}^{H(s)} \oplus l_{H(s)}) \cdot (l_{H(s)} \oplus \vee_{H(s)})) \uparrow^{H(s)} ] \\
&\quad \cdot H((l_c \oplus \wedge_{m-1}^s)v) \\
&= H(u(l_c \oplus \vee_s^{n-1})) \cdot H((l_c \oplus \wedge_{m-1}^s)v) \quad \text{FD} \\
&= H(u(l_c \oplus \vee_s^{n-1})) \cdot (l_c \oplus \wedge_{m-1}^s)v \\
&= H(f \uparrow^s) \quad \square
\end{aligned}$$

**Theorem 6.4** *Suppose we are given*

- a restriction  $xy$  such that  $x = b$  or  $y = \beta$  or  $xy \in \{a\alpha, d\delta\}$  and
- an  $xy$ -ssmc with feedback  $B$  over a monoid  $M$ .

Then for every morphism of monoids  $h : S^* \rightarrow M$  there exists a unique morphism of  $xy$ -ssmc's with feedback

$$H : xy\text{-Rel}_S \rightarrow B$$

which extends  $h$ .  $\square$

## 6.2 Algebra of flowgraphs with various constants ( $xy$ -ssmc with feedback)

In Chapters 4 and 5 we have described the basic model for flowgraphs modulo isomorphism. One may use arbitrary relations there, but at the syntactic level only bijections (constants  $l, \mathbf{X}$ ) are required. Here we extend the algebra to the full syntax of the calculus of flownomials

$$\oplus \cdot \uparrow^a \quad {}^a\mathbf{X}^b \quad \wedge_k^a \quad \vee_a^k$$

by adding axiomatisations for  $\wedge_k$  and  $\vee^k$ . To this end, we use the results in Chapter 2 which give free presentations for certain classes of relations as  $xy$ -ssmc and Theorem 6.4 that shifts that axiomatisations in the cyclic setting. We get the following results

**Theorem 6.5** *Let  $xy$  be a restriction with  $x \in \{a, b, c, d\}$  and  $y \in \{\alpha, \beta, \gamma, \delta\}$  such that  $x = b$  or  $y = \beta$  or  $xy \in \{a\alpha, d\delta\}$ .*

*If  $T$  is an  $xy$ -ssmc with feedback, then*

- (Correctness)  $\mathbb{F}\ell_{a\alpha}[X, T]$  is an  $xy$ -ssmc with feedback.
- (Completeness) The rules of  $xy$ -ssmc with feedback are complete for flowgraphs with  $xy$ -constants modulo isomorphism.  $\square$

## 6.3 Short comments and references

The key result of this chapter (i.e. the axiomatisation of various classes of relations in the presence of the feedback operation) is from [CaS88c]. The presentation follows Chapter C, sec. 1 of [Ste91].

**Part III**

**Algebras of Flowgraph Behaviours**

# Chapter 7

## Flowgraph behaviours; general facts

In this chapter we define the  $xy$ -flow structure which is the basic algebraic structure we are using to axiomatise various kinds of flowgraph behaviours.

To this end, two rules for the identification of flowgraphs are introduced: the enzymatic rule and simulation. Such rules are necessary in order to extend certain simple axiomatisations for acyclic flowgraphs to the case of cyclic ones.

The simulation rule is defined on normal form expressions, whilst the enzymatic rule may be used for arbitrary ones. In the particular setting we are using in this paper both rules generate the same equivalences on flowgraphs.<sup>1</sup>

### 7.1 Enzymatic rule

#### 7.1.1 The rôle of the enzymatic rule

For the beginning we work in the theory  $\mathbf{AF}\ell[X, \mathbb{R}el]$  of acyclic flowgraphs built up with atoms in  $X$  and connections in  $\mathbb{R}el$ . These graphs are precisely those built up from the atoms and the connections using the operations of summation and composition, namely they correspond to flownomial expressions without feedback.

In this theory the equivalence relations generated by the identification rules in Table 7.1 will be studied.

In order to simplify the understanding we study the deterministic case, i.e.  $\mathbf{AF}\ell[X, \mathbb{P}fn]$ . Denote by

$\equiv_{xy}$  the congruence relation in  $\mathbf{AF}\ell_{X, Pfn}$  generated by the identifications ( $C_{uv}$ -var) in Table 7.1 for  $u \prec_L x$  and  $v \prec_G y$ .

---

<sup>1</sup>In general, it seems that the enzymatic rule (plus the corresponding strong commutations axioms) is more powerful than simulation.

Table 7.1: Commutation of the constants with variables ( $x : a \rightarrow b$ ).

$(C_{a\beta}$ -var)	$\top_a \cdot x = \top_b$	$(C_{b\beta}$ -var)	$x \cdot \perp^b = \perp^a$
$(C_{a\gamma}$ -var)	$\vee_a \cdot x = (x \oplus x) \cdot \vee_b$	$(C_{c\alpha}$ -var)	$x \cdot \wedge^b = \wedge^a \cdot (x \oplus x)$

These congruences give natural equivalence relations on acyclic graphs. For example,  $\equiv_{a\beta}$  captures accessibility, i.e. two acyclic graphs  $F$  and  $F'$  are  $\equiv_{a\beta}$ -equivalent if and only if they have the same accessible part.

Do the analogous statements work for cyclic graphs? The answer is “not”. The following example may help us to understand why.

**Example 7.1** (graphs over  $\mathbb{I}n$  and a biscalar variable)

Suppose  $X$  has only a variable  $x : 1 \rightarrow 1$ , i.e.

$$X(1, 1) = \{x\} \quad \text{and} \quad X(m, n) = \emptyset \quad \text{otherwise}$$

Denote  $x^0 = 1_1$  and  $x^{n+1} = x \cdot x^n$  for  $n \geq 0$ .

Every acyclic graph in  $\mathbf{AFL}[X, \mathbb{I}n](m, n)$  may be represented as

$$\left( \sum_{i \in [m]} x^{k_i} \oplus \top_p \cdot \sum_{i \in [p]} x^{r_i} \right) \cdot c \quad \text{with } c \in \mathbb{I}n(m+p, n), \text{ all } k_i \geq 0, \text{ all } r_j \geq 1,$$

so that it is uniquely determined by the pair  $(k_1, \dots, k_m; r_1, \dots, r_p)$  of sequences of natural numbers and the injection  $c$ .

If  $\equiv_{a\beta}$  is the congruence relation (with respect to “ $\oplus$ ” and “ $\cdot$ ”) generated by the identifications ( $C_{a\alpha}$ -var), then

two acyclic graphs  $F$  and  $F'$  represented by  $(k_1, \dots, k_m; r_1, \dots, r_p)$  and  $c$ , and by  $(k'_1, \dots, k'_m; r'_1, \dots, r'_p)$  and  $c'$ , respectively, are  $\equiv_{a\beta}$ -equivalent

if and only if

$$k_i = k'_i, \quad \forall i \in [m] \quad \text{and} \quad (l_m \oplus \top_p) \cdot c = (l_m \oplus \top_{p'}) \cdot c',$$

that is if and only if

$F$  and  $F'$  have the same accessible part.

Every cyclic graph in  $\mathbb{FL}_{a\alpha}[X, \mathbb{I}n] / \Rightarrow_{Tr} (m, n)$  may be represented as

$$\left( \sum_{i \in [m]} x^{k_i} \oplus \top_p \cdot \sum_{i \in [p]} x^{r_i} \right) \cdot c \oplus \sum_{i \in [q]} (x^{s_i} \uparrow),$$

where  $c \in \mathbb{I}n(m+p, n)$ , all  $k_i \geq 0$ , all  $r_i \geq 1$ , and all  $s_i \geq 1$ . Hence it is uniquely determined by the triple  $(k_1, \dots, k_m; r_1, \dots, r_p; s_1, \dots, s_q)$  of sequences of natural numbers and the injection  $c$ .

If  $\approx_{a\beta}$  is the congruence relation (with respect to “ $\oplus$ ”, “ $\cdot$ ” and “ $\uparrow$ ”) generated by the identifications ( $C_{a\beta}$ -var), then

two cyclic graphs  $F$  and  $F'$  represented by  $(k_1, \dots, k_m; r_1, \dots, r_p; s_1, \dots, s_q)$  and  $c$ , and by  $(k'_1, \dots, k'_m; r'_1, \dots, r'_p; s'_1, \dots, s'_q)$  and  $c'$ , respectively, are  $\approx_{a\beta}$ -equivalent

if and only if

$$k_i = k'_i, \quad \forall i \in [m] \quad \text{and} \quad (l_m \oplus \top_p) \cdot c = (l_m \oplus \top_{p'}) \cdot c' \quad \text{and} \quad q = q' \quad \text{and} \quad s_i = s'_{\sigma(i)}, \quad \forall i \in [q],$$

where  $\sigma$  is a bijection in  $\mathbb{Bi}(q, q)$ .

This means that

$$F \approx_{a\beta} F'$$

if and only if

$F$  and  $F'$  have the same accessible part and the same (inaccessible) cycles.

Hence  $\approx_{a\beta}$  does not capture accessibility.  $\square$

The reason for the negative answer above is the impossibility to use the identifications given by  $(C_{xy}\text{-var})$  in cycles. Consequently, the congruence relation generated by such identification is too strong, i.e. it identifies too few graphs.

In order to overcome this difficulty we combine the identifications  $(C_{xy}\text{-var})$  with an additional identification rule, called the enzymatic rule. This rule allows to use the identifications given by  $(C_{xy}\text{-var})$  in cycles. It is defined as follows.

**Definition 7.2** (enzymatic rule)

Take the implication

$$(Enz_{y,f,g}) \quad f \cdot (l_m \oplus y) \sim (l_m \oplus y) \cdot g \Rightarrow f \uparrow^p \sim g \uparrow^q$$

where  $f : m \oplus p \rightarrow n \oplus p$ ,  $g : m \oplus q \rightarrow n \oplus q$ ,  $y : p \rightarrow q$ .

We say *an equivalence relation  $\sim$  on  $T$  satisfies the enzymatic rule  $Enz_E$* , where  $E$  is a class of morphisms of  $T$ , if  $\sim$  satisfies the implication  $Enz_{y,f,g}$  for  $y$  in  $E$  and arbitrary  $f, g$ . Finally, we say  *$T$  satisfies the enzymatic rule  $Enz_E$*  if the relation of equality in  $T$  satisfies  $Enz_E$ .  $\square$

Now in the case of cyclic graphs in  $\mathbb{F}\ell_{a\alpha}[X, \mathbb{P}\text{fn}]/\Rightarrow_{Tr}$  certain natural equivalence relations (corresponding to those noted in the acyclic case) are precisely captured by the congruence relations generated by identifications  $(C_{xy}\text{-var})$  in the class of congruence relations satisfying  $Enz_{x'y'}$ .

For example, the congruence relation  $\sim_{a\alpha}$  generated by the identifications  $(C_{a\beta}\text{-var})$  in the class of congruence relations satisfying  $Enz_{a\beta}$  means: two cyclic graphs  $F$  and  $F'$  are  $\sim_{a\beta}$ -equivalent if and only if  $F$  and  $F'$  have the same accessible part.

**Example 7.3** (Example 7.1 continued)

Take three graphs

$$F, F', F'' \in [\mathbb{F}\ell[X, In]/\Rightarrow_{Tr}](m, n)$$

where  $X$  is as in the above example. Suppose they are respectively represented by

$$\begin{aligned} & (k_1, \dots, k_m; r_1, \dots, r_p; s_1, \dots, s_q) \text{ and } c, \\ & (k_1, \dots, k_m; \lambda; s_1, \dots, s_q) \text{ and } (l_m \oplus \top_p) \cdot c, \text{ and} \\ & (k_1, \dots, k_m; \lambda; \lambda) \text{ and } (l_m \oplus \top_p) \cdot c, \text{ respectively} \end{aligned}$$

where  $\lambda$  is the empty sequence. It is clear that  $F \approx_{a\beta} F'$  and  $F''$  is the accessible part of  $F$ . Let  $G : m + q \rightarrow n + q$  be the flowgraph represented by

$$(k_1, \dots, k_m, s_1, \dots, s_q; \lambda; \lambda) \text{ and } (l_m \oplus \top_p) \cdot c \oplus \top_q.$$

Since

$$F'' \cdot (l_n \oplus \top_q) \approx_{a\beta} (l_m \oplus \top_p) \cdot G$$

using the enzymatic rule  $Enz_{a\beta}$  one gets  $F'' \uparrow^0 \sim_{a\beta} G \uparrow^q = F'$ . Hence the difficulty was overcome: a graph is  $\sim_{a\beta}$ -equivalent with its accessible part.  $\square$



## 7.1.2 Validity of the enzymatic rule in some semantic domains

We insert here a semantical justification of the enzymatic rule.

**Proposition 7.4** *In  $\mathbb{R}el(D)$  the enzymatic rule holds for every morphism, i.e.  $Enz_{\mathbb{R}el(D)}$  is valid.*

**Proof:** Suppose  $f \in \mathbb{R}el(D)(m+p, n+p)$ ,  $g \in \mathbb{R}el(D)(m+q, n+q)$  and  $y \in \mathbb{R}el(D)(p, q)$  fulfill condition

$$f \cdot (l_n \oplus y) = (l_m \oplus y) \cdot g$$

Write  $f$  and  $g$  as matrices

$$f = \begin{pmatrix} f_{11} & f_{12} \\ f_{21} & f_{22} \end{pmatrix} \quad \text{and} \quad g = \begin{pmatrix} g_{11} & g_{12} \\ g_{21} & g_{22} \end{pmatrix}$$

with  $f_{11}, g_{11} : m \rightarrow n$ . Then equality  $f \cdot (l_n \oplus y) = (l_m \oplus y) \cdot g$  give four ones

$$\begin{aligned} f_{11} &= g_{11} \\ f_{12} \cdot y &= g_{12} \\ f_{21} &= y \cdot g_{21} \\ f_{22} \cdot y &= y \cdot g_{22} \end{aligned}$$

From the definition of the feedback in  $\mathbb{R}el(D)$  one gets

$$f \uparrow^p = f_{11} \cup f_{12} \cdot f_{22}^* \cdot f_{21}$$

where  $f_{22}^* = l_p \cup f_{22} \cup f_{22}^2 \dots$ . Similarly

$$g \uparrow^q = g_{11} \cup g_{12} \cdot g_{22}^* \cdot g_{21}$$

Using the relationship between  $f_{ij}$  and  $g_{ij}$  one gets

$$\begin{aligned} g \uparrow^q &= f_{11} \cup f_{12} \cdot y (l_q \cup g_{22} \cup g_{22}^2 \dots) \cdot g_{21} \\ &= f_{11} \cup f_{12} \cdot (y \cup y \cdot g_{22} \cup y \cdot g_{22}^2 \dots) \cdot g_{21} \\ &= f_{11} \cup f_{12} \cdot (y \cup f_{22} \cdot y \cup f_{22}^2 \cdot y \dots) \cdot g_{21} \\ &= f_{11} \cup f_{12} \cdot (l_p \cup f_{22} \cup f_{22}^2 \dots) \cdot y \cdot g_{21} \\ &= f_{11} \cup f_{12} \cdot f_{22}^* \cdot f_{21} \\ &= f \uparrow^p \end{aligned}$$

□

**Corollary 7.5** *An  $\alpha$ -flow  $T$  included in  $\mathbb{R}el(D)$  satisfies axiom  $Enz_T$ . □*

### 7.1.3 Generating congruences in algebras with conditional equations

From the above observations it follows that we are interested in the congruence relations generated by certain identifications ( $C_{xy}$ -var) in the class of congruence relations satisfying the enzymatic rule  $\text{Enz}_{xy}$ , for various restrictions  $xy$ . Condition  $\text{Enz}_E$  is not equational, it is a conditional equation. The question that appear here is: how such a congruence may be generated? Below we give a construction useful in the general context of universal algebras with conditional equations.

Let  $A$  be a universal algebra having  $S$  as the sort set and  $\sigma$  as the set of operations. Moreover, let  $R \subseteq A \times A$  be a relation and denote by  $\text{Ref}(R)$  (resp.  $\text{Sym}(R)$ ,  $\text{Op}(R)$ ,  $\text{Trans}(R)$ ,  $C(R)$ ,  $C_J(R)$ ) the least relation containing  $R$  and being reflexive (resp. symmetric, compatible with the operations, transitive, congruence, congruence satisfying the set  $J$  of implications).

**Definition 7.6** By a *conditional equation* we mean an implication written in terms of the free algebra  $T_\Sigma(X)$  as:

$$\langle X; t_1 = t'_1 \ \& \ \dots \ \& \ t_r = t'_r \Rightarrow t = t' \rangle,$$

where  $t_1, t'_1 \in T_\Sigma(X)_{s_1}$ ,  $\dots$ ,  $t_r, t'_r \in T_\Sigma(X)_{s_r}$ ,  $t, t' \in T_\Sigma(X)_s$ .

A congruence relation  $\sim$  on  $A$  satisfies the above conditional equation if:

if  $f : X \rightarrow A$  is an arbitrary function, then its (unique) extension to terms  $f^\# : T_\Sigma(X) \rightarrow A$  satisfies the implication:  
 $f^\#(t_1) \sim f^\#(t'_1)$  and  $\dots$  and  $f^\#(t_r) \sim f^\#(t'_r)$  implies  $f^\#(t) \sim f^\#(t')$ .

Finally, we say  $A$  satisfies the *conditional equation* if the equality relation on  $A$  satisfies this conditional equation. <sup>2</sup>  $\square$

The construction of the congruence relation  $C(R)$  generated by a relation  $R$  is well-known. We recall it and then extend the result to algebras with conditional equations.

**Proposition 7.7**  $C(R) = \text{Trans}(\text{Op}(\text{Sym}(\text{Ref}(R))))$ .  $\square$

**Proposition 7.8** Define inductively the congruences

$$C_J^0(R) = C(R)$$

and for  $k \geq 0$ ,

$$C_J^{k+1} = C(R \cup E_k),$$

where

$$E_k = \{(f^\#(t), f^\#(t')) : \exists \langle X; t_1 = t'_1 \ \& \ \dots \ \& \ t_r = t'_r \Rightarrow t = t' \rangle \in J \text{ and } f : X \rightarrow A \text{ such that } (f^\#(t_j), f^\#(t'_j)) \in C_J^k(R), \forall j \in [r]\}$$

Then the sequence  $C_J^k(R)$  of congruences is increasing and

$$C_J(R) = \bigcup_{k \geq 0} C_J^k(R).$$

---

<sup>2</sup>With  $J$  above we have denoted a set of such conditional equations in which the number of premises is finite.

**Proof:** By induction we show that

$$R \subseteq C_J^0(R) \subseteq C_J^1(R) \subseteq \dots \subseteq C_J^k(R) \subseteq \dots$$

The first two inclusions obviously hold. For the inductive step, let us notice that

$$\begin{aligned} C_J^k(R) \subseteq C_J^{k+1}(R) &\Rightarrow E_k \subseteq E_{k+1} \\ &\Rightarrow C_J^{k+1}(R) \subseteq C_J^{k+2}(R) \end{aligned}$$

Since  $(C_J^k(R))_{k \in \mathbb{N}}$  is an increasing sequence of congruences it follows that  $C_J(R) = \bigcup_{k \geq 0} C_J^k(R)$  is a congruence, too.

Finally, let us observe that  $C_J(R)$  satisfy the conditional equations. Indeed, let

$$\langle X; t_1 = t'_1 \ \& \ \dots \ \& \ t_r = t'_r \Rightarrow t = t' \rangle \in J$$

be an conditional equation and  $f : X \rightarrow A$  a valuation. Suppose moreover that  $(f^\#(t_j), f^\#(t'_j)) \in C_J(R)$ . The sequence  $C_J^k(R)$  is increasing, hence there is an index  $k_0$  such that all the pairs above are in the same  $C_J^{k_0}(R)$ . Hence

$$(f^\#(t), f^\#(t')) \in E_{k_0} \subseteq C_J^{k_0+1}(R) \subseteq C_J(R)$$

□

## 7.1.4 Extending $xy$ -strong axioms

The example given 7.1 has shown that if we impose locally on  $X$  and  $T$  the  $xy$ -strong axioms, then we can not prove that the  $xy$ -strong axioms hold true in the set of all flowgraphs over  $X$  and  $T$  (for example,  $\top_0 \cdot (x \uparrow^s) \not\approx_{a\beta} \top_0$ ). Hence certain global constrains are to be imposed on all flowgraphs. Such a condition is the enzymatic rule.

**Theorem 7.9** *Let  $T$  be an  $a\alpha$ -flow and a strong  $xy$ -ssmc.*

*If  $\sim$  is a congruence on  $\text{NF}\ell[X, T]$  such that:*

$$\sim \text{ contains } \Rightarrow_{Tr},$$

$$\sim \text{ contains the identifications } (C_{xy\text{-var}}), \text{ and}$$

$$\sim \text{ satisfies } \text{Enz}_{xy},$$

*then  $\text{NF}\ell[X, T]/\sim$  is an  $a\alpha$ -flow and a strong  $xy$ -ssmc.*

**Proof:** Since  $\Rightarrow_{Tr} \subseteq \sim$ , the quotient  $\text{NF}\ell[X, T]/\sim$  is a qotient of  $\text{NF}\ell[X, T]/\Rightarrow_{Tr}$ , too. But the latter is an  $a\alpha$ -flow, hence the former is an  $a\alpha$ -flow, too.

Below we check the  $xy$ -strong conditions. Suppose  $F = [(l_m \oplus \underline{x}) \cdot f] \uparrow^{i(\underline{x})} \in \text{NF}\ell[X, T](m, n)$ .

1. For  $(C_{a\beta\text{-mor}}$ ) first notice that

$$\top_m \cdot F = [(l_0 \oplus \underline{x}) \cdot (\top_m \oplus l_{o(\underline{x})}) \cdot f] \uparrow^{i(\underline{x})}$$

Then

$$\begin{aligned}
(l_0 \oplus \top_{i(\underline{x})}) \cdot [(l_0 \oplus \underline{x}) (\top_m \oplus l_{o(\underline{x})}) f] &\sim (l_0 \oplus \top_{o(\underline{x})}) (\top_m \oplus l_{o(\underline{x})}) \cdot f && (\text{C}_{a\beta}\text{-var}) \\
&= \top_{m \oplus o(\underline{x})} \cdot f \\
&= \top_{n \oplus i(\underline{x})} && (\text{C}_{a\beta}\text{-mor}) \text{ in } T \\
&= \top_n \cdot (l_n \oplus \top_{i(\underline{x})})
\end{aligned}$$

Applying  $\text{Enz}_{a\beta}$  we get

$$[(l_0 \oplus \underline{x}) (\top_m \oplus l_{o(\underline{x})}) f] \uparrow^{i(\underline{x})} \sim \top_n \uparrow^0$$

hence

$$\top_m \cdot F \sim \top_n$$

2. For  $(\text{C}_{a\gamma}\text{-mor})$  first notice that

$$(F \oplus F) \cdot \vee_n = g \uparrow^{i(\underline{x}) \oplus i(\underline{x})}$$

where

$$g = (l_{m \oplus m} \oplus \underline{x} \oplus \underline{x}) \cdot (l_m \oplus {}^m\mathbf{X}^{o(\underline{x})} \oplus l_{o(\underline{x})}) \cdot (f \oplus f) \cdot (l_n \oplus {}^{i(\underline{x})}\mathbf{X}^n \oplus l_{i(\underline{x})}) \cdot (\vee_n \oplus l_{i(\underline{x}) \oplus i(\underline{x})})$$

Then

$$\begin{aligned}
g \cdot (l_n \oplus \vee_{i(\underline{x})}) &= (l_{2m} \oplus \underline{x} \oplus \underline{x}) \cdot (l_m \oplus {}^m\mathbf{X}^{o(\underline{x})} \oplus l_{o(\underline{x})}) \cdot (f \oplus f) \cdot \vee_{n \oplus i(\underline{x})} \\
&= (l_{2m} \oplus \underline{x} \oplus \underline{x}) \cdot (l_m \oplus {}^m\mathbf{X}^{o(\underline{x})} \oplus l_{o(\underline{x})}) \cdot \vee_{m \oplus o(\underline{x})} \cdot f && (\text{C}_{a\gamma}\text{-mor}) \text{ in } T \\
&= (l_{2m} \oplus \underline{x} \oplus \underline{x}) \cdot (\vee_m \oplus \vee_{o(\underline{x})}) \cdot f \\
&= (l_{2m} \oplus (\underline{x} \oplus \underline{x}) \cdot \vee_{o(\underline{x})}) \cdot (\vee_m \oplus l_{o(\underline{x})}) \cdot f \\
&\sim (l_{2m} \oplus \vee_{i(\underline{x})}) \cdot [(l_{2m} \oplus \underline{x}) \cdot (\vee_m \oplus l_{o(\underline{x})}) \cdot f] && (\text{C}_{a\gamma}\text{-var})
\end{aligned}$$

Applying  $\text{Enz}_{a\gamma}$  we get

$$\begin{aligned}
g \uparrow^{i(\underline{x}) \oplus i(\underline{x})} &\sim [(l_{2m} \oplus \underline{x}) \cdot (\vee_m \oplus l_{o(\underline{x})}) f] \uparrow^{i(\underline{x})} \\
&= \vee_m \cdot F
\end{aligned}$$

hence

$$\vee_m \cdot F \sim (F \oplus F) \cdot \vee_n$$

3. The proof of  $F \cdot \perp^n \sim \perp^m$  is dual to the first case.

4. The proof of  $F \cdot \wedge^n \sim \wedge^m \cdot (F \oplus F)$  is dual to the second case.

□

We finish this section with a result that simplifies the verification of the enzymatic rule.

**Lemma 7.10** *If the enzymatic axiom holds for two morphisms, then it also holds for their sum. Put formally,*

$$\text{Enz}_{\{u\}} \ \& \ \text{Enz}_{\{u'\}} \Rightarrow \text{Enz}_{\{u \oplus u'\}}$$

**Proof:** Let say that  $u : p \rightarrow q$  and  $u' : p' \rightarrow q'$ . Take arbitrary  $f : m \oplus p \oplus p' \rightarrow n \oplus p \oplus p'$  and  $g : m \oplus q \oplus q' \rightarrow n \oplus q \oplus q'$  such that the premise holds, i.e.

$$f \cdot (l_n \oplus u \oplus u') = (l_m \oplus u \oplus u') \cdot g$$

Write this identity as

$$[f(l_n \oplus u \oplus l_{p'})] \cdot (l_{n \oplus q} \oplus u') = (l_{m \oplus p} \oplus u') \cdot [(l_m \oplus u \oplus l_{q'})g]$$

and apply  $\text{Enz}_{\{u'\}}$ . We get

$$[f(l_n \oplus u \oplus l_{p'})] \uparrow^{p'} = [(l_m \oplus u \oplus l_{q'})g] \uparrow^{q'}$$

With axiom R7 we may write this identity as

$$(f \uparrow^{p'}) \cdot (l_n \oplus u) = (l_m \oplus u) \cdot (g \uparrow^{q'})$$

and apply  $\text{Enz}_{\{u\}}$ . We get

$$(f \uparrow^{p'}) \uparrow^p = (g \uparrow^{q'}) \uparrow^q$$

or equivalently,

$$f \uparrow^{p \oplus p'} = g \uparrow^{q \oplus q'}$$

□

## 7.2 $xy$ -flow

Our basic algebras for the axiomatisation of the different notions of flowgraph behaviour are obtained by adding the enzymatic rule to the  $xy$ -strong axioms. They are defined below.

**Definition 7.11** ( $xy$ -flow)

Let  $xy$  be a restriction with  $x \in \{a, b, c, d\}$  and  $y \in \{\alpha, \beta, \gamma, \delta\}$  and let  $\hat{x}\hat{y}$  be the least restriction greater than  $xy$  (i.e.  $x \prec_L \hat{x}$  and  $y \prec_G \hat{y}$ ) and closed to feedback (i.e. satisfying the condition:  $\hat{x} = b$  or  $\hat{y} = \beta$  or  $\hat{x}\hat{y} \in \{a\alpha, d\delta\}$ ).

An  $xy$ -flow is a structure  $T$  satisfying the following conditions:

- $T$  is a  $\hat{x}\hat{y}$ -ssmc with feedback;
- $T$  is a strong  $xy$ -ssmc; and
- $T$  satisfies the enzymatic rule  $\text{Enz}_{xy}$ .

A *morphism of  $xy$ -flows* is a morphism of  $xy$ -ssms's that preserves the feedback operation. □

Let us note the coincidence of the definition of the  $a\alpha$ -flow structure given before (Definition 4.10) with the particular instance of the above definition in the case  $xy = a\alpha$ .

Another observation: The passage from  $xy$  to  $\hat{x}\hat{y}$  is made by adding constants of type  $\top$  or  $\perp$ , eventually. In the definition of morphisms of  $xy$ -flows we do not require the commutation with these constants since this follows from the axioms FC and FC<sup>o</sup> used in the definition of ssmc's with feedback.

## 7.3 Simulation

### 7.3.1 Examples

From the comments made in the previous section it follows that we are interested in the congruence relation  $\sim_{xy}$  generated by the rule of commutation of  $xy$ -morphisms with variables ( $C_{xy}$ -var) in the class of congruence relations satisfying  $\text{Enz}_{xy}$ . The iterative process of construction of  $\sim_{xy}$  given by Proposition 7.8 is difficult, it produces  $\sim_{xy}$  by a doubly iterative algorithm. In order to simplify it we use the relation of simulation that may be considered as the first step of the closure of ( $C_{xy}$ -var) to  $\text{Enz}_{xy}$ .

More precisely, the combination of ( $C_{xy}$ -var) with  $\text{Enz}_{xy}$  gives simulation. This is a transformation of the normal form flownomial expressions that inherits the form of an enzymatic process. The rôle of enzymes is played by  $xy$ -morphisms.<sup>3</sup>

#### **Enzymatic transformation of normal form flownomial expressions.**

Suppose we are given a flowgraph represented by the n.f. flownomial expression

$$F = [(l_m \oplus x_1 \oplus \dots \oplus x_k) \cdot f] \uparrow^{i(x_1) \oplus \dots \oplus i(x_k)}$$

Let us introduce an enzyme (perturbation)

$$r : \alpha \rightarrow i(x_1) \oplus \dots \oplus i(x_k)$$

on the feedback in the top of the variables/atoms and cut the feedback. Move the enzyme through the flowgraph trying to pass over the variables, then over the connections, and finally displace it along the feedback. If the enzyme is reproduced at the end of the transformation, then take out the enzyme, reconnect the resulted feedback, and declare the resulted flowgraph  $F'$  equivalent to the initial one.

The process may also be applied in the dual form, starting with an enzyme

$$r : i(x_1) \oplus \dots \oplus i(x_k) \rightarrow \alpha$$

and moving the enzyme on the oposite sense.

**Example 7.12** Two example are given in Figures 7.1 and 7.2.  $\square$

This, perhaps strange, method of transformation of flownomials proves to be very useful. Its meaning depends on the type of the enzymes and it is presented in Table 7.2 in some particular, but typical, cases.

### 7.3.2 Definition; general properties

Let us be more precise in the definition of simulation.

**Notation 7.13** ( $i(u)$ ,  $o(u)$ )

---

<sup>3</sup>This transformation may be considered as a slight mathematical formulation of Hegel's law of circular evolution.

Table 7.2: The meaning of simulation

The enzymes $r$ used	The meaning of simulation	
$a\alpha$ : bijections	$F \xrightarrow{a\alpha}_u F' \Leftrightarrow$	$\mathbf{gr}(F) = \mathbf{gr}(F')$ (i.e., both fluxnomial expressions $F$ and $F'$ represent the same flowgraph; the bijection $u$ gives the passage from the linearization in $F$ to the one in $F'$ )
$a\beta$ : injections	$F \xrightarrow{a\beta}_u F' \Leftrightarrow$	$\mathbf{gr}(F')$ has a subgraph isomorphic with $\mathbf{gr}(F)$ and –in addition– has a part with no incoming arrows from this copy of $\mathbf{gr}(F)$ (this additional part corresponds to the complement of $Im(u)$ )
$a\gamma$ : surjections	$F \xrightarrow{a\gamma}_u F' \Leftrightarrow$	$\mathbf{gr}(F')$ may be obtained from $\mathbf{gr}(F)$ by identifying vertices that have common label and their outgoing connections match (two vertices $x$ and $x'$ are identified iff $u(x) = u(x')$ )
$b\alpha$ : converses of injections	$F \xrightarrow{b\alpha}_u F' \Leftrightarrow$	$\mathbf{gr}(F)$ has a subgraph isomorphic with $\mathbf{gr}(F')$ and –in addition– has a part with no outgoing arrows to this copy of $\mathbf{gr}(F')$ (this additional part corresponds to the complement of $Dom(u)$ )
$c\alpha$ : converses of surjections	$F \xrightarrow{c\alpha}_u F' \Leftrightarrow$	$\mathbf{gr}(F)$ may be obtained from $\mathbf{gr}(F')$ by identifying vertices that have common label and their incoming connections match (two vertices $x$ and $x'$ in $F'$ are identified iff $\exists v$ in $F : (v, x) \in u$ and $(v, x') \in u$ )

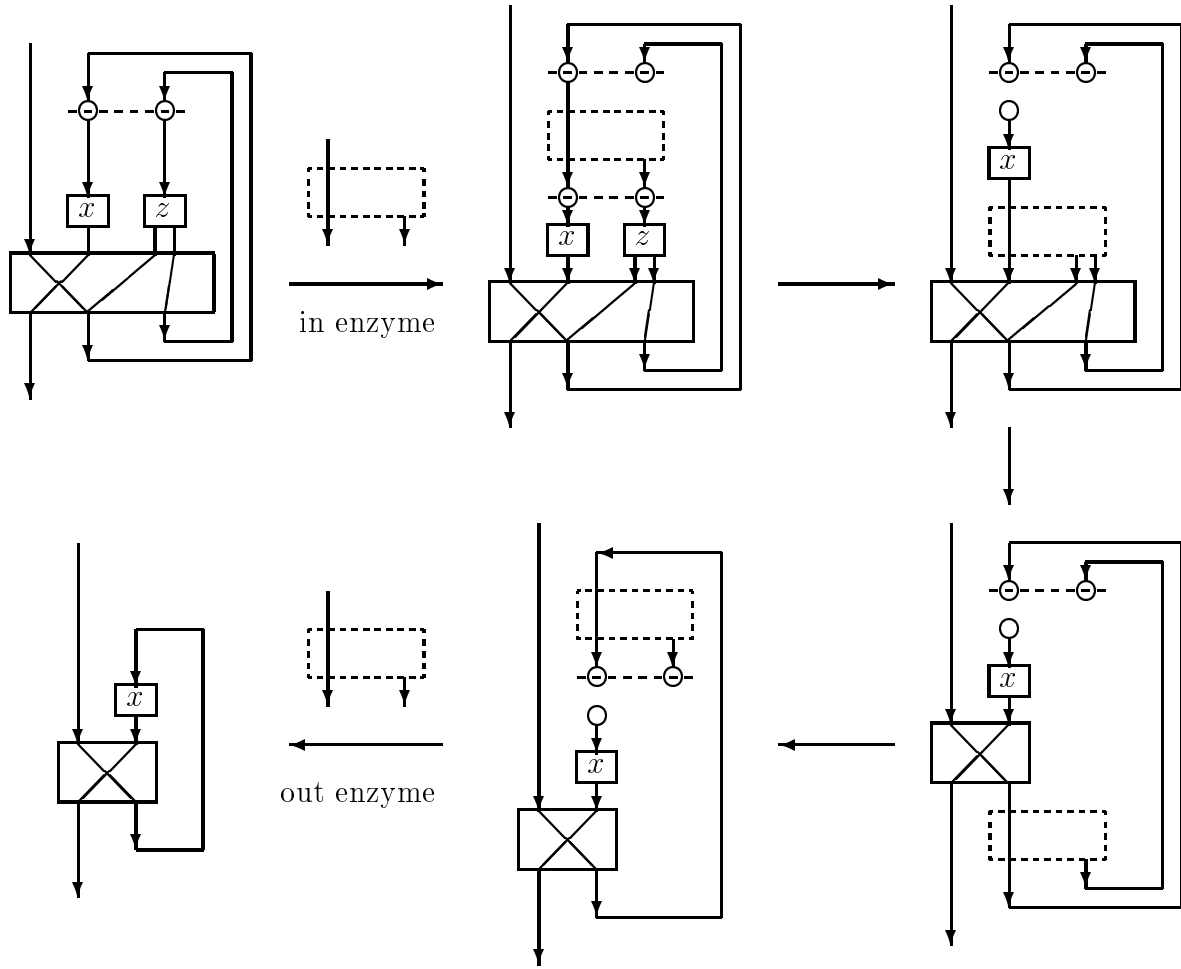

Figure 7.1: Simulation via injections (case  $a\beta$ )

Suppose  $T$  is an  $xy$ -ssmc over a monoid  $M$  and it is endowed with a feedback operation. For an  $X$ -sorted  $xy$ -relation  $u \in xy\text{-Rel}_X(a, b)$  denote by

$$i(u) \in T(i(a), i(b))$$

its extension to inputs, namely the image of  $u$  via the unique morphism of  $xy$ -ssmc's  $H : \mathbb{R}el_X \rightarrow T$  that extends  $i : X \rightarrow M$ .<sup>4</sup>

Similarly, we denote by  $o(u)$  the extension to outputs.  $\square$

**Definition 7.14** (simulation; general case)

Suppose we are given two normal form flownomial expressions  $F, F' \in \text{INF}\ell[X, T](m, n)$ , say

$$F = [(l_m \oplus x_1 \oplus \dots \oplus x_k) \cdot f] \uparrow^{i(x_1) \oplus \dots \oplus i(x_k)} \text{ and}$$

$$F' = [(l_m \oplus x'_1 \oplus \dots \oplus x'_{k'}) \cdot f'] \uparrow^{i(x'_1) \oplus \dots \oplus i(x'_{k'})}.$$

<sup>4</sup>This extension is provided by Theorem 2.24.



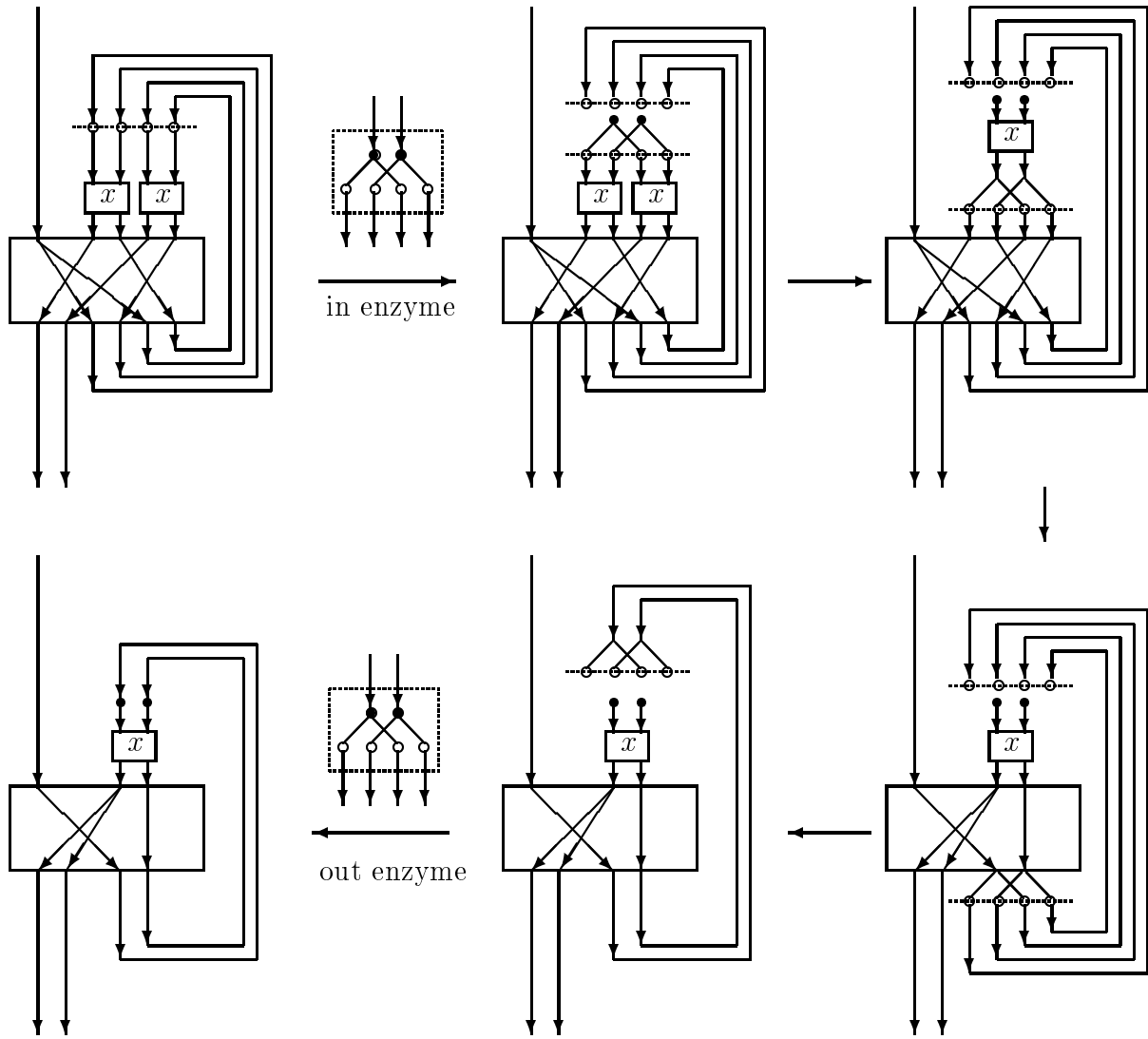

Figure 7.2: Simulation via converses of surjections (case  $c\alpha$ )

We say a relation between vertices

$$u \in \mathbb{R}el(k, k')$$

is a *simulation from  $F$  to  $F'$*  (or that  $F$  and  $F'$  are *similar via  $u$* ) and write  $F \rightarrow_u F'$  or  $F \xrightarrow{u} F'$  iff

- (i)  $(j, j') \in u \Rightarrow x_j = x'_{j'}$ , and
- (ii)  $f \cdot (l_n \oplus i(u)) = (l_m \oplus o(u)) \cdot f'$ .

By definition  $F \xrightarrow{xy} F'$  means  $F \rightarrow_u F'$  for an  $xy$ -morphism  $u$ .  $\square$

Condition (i) actually shows that relation  $u$  preserves the variables, hence

$$u \in \mathbb{R}el_X(x_1 \oplus \dots \oplus x_k, x'_1 \oplus \dots \oplus x'_{k'})$$

and condition (ii) gives a corelation between the connections of  $F$  and  $F'$ .

It is also easy to see that simulation via a transposition  $\rightarrow_{Tr}$  (Definition 5.3 is a particular case of the above definition (namely when  $u = l_j \oplus {}^1X^1 \oplus l_{k-j-2}$ ) and the generated congruence  $\Rightarrow_{Tr}$  coincides with  $\xrightarrow{a\alpha}$ .

**Proposition 7.15** *(( $C_{xy}$ -var) &  $Enz_{xy} \Rightarrow$  Simulation via  $xy$ -morphisms)*

*Let  $\sim$  be a congruence on  $\text{NF}\ell[X, T]$  such that*

*$\sim$  contains  $\Rightarrow_{Tr}$*

*$\sim$  contains  $C_{xy}$ -var and*

*$\sim$  obeys condition  $Enz_{xy}$ .*

*Then  $\sim$  contains simulation via  $xy$ -morphisms.*

**Proof:** Let

$$[(l_m \oplus \underline{x}) \cdot f] \uparrow^{i(\underline{x})} \rightarrow_u [(l_m \oplus \underline{x}') \cdot f'] \uparrow^{i(\underline{x}')}$$

where  $\underline{x} = x_1 \oplus \dots \oplus x_k$ ,  $\underline{x}' = x'_1 \oplus \dots \oplus x'_{k'}$ , and  $u \in xy\text{-IRel}(k, k')$ . One may see that

$$\begin{aligned} [(l_m \oplus \underline{x})f] \cdot (l_n \oplus i(u)) &= (l_m \oplus \underline{x}) (l_m \oplus o(u)) \cdot f' \\ &= [l_m \oplus (x_1 \oplus \dots \oplus x_k) \cdot o(u)] \cdot f' \\ &\sim [l_m \oplus i(u) \cdot (x'_1 \oplus \dots \oplus x'_{k'})] \cdot f' \\ &= (l_m \oplus i(u)) \cdot [(l_m \oplus \underline{x}')f'] \end{aligned}$$

(The third step follows by a proof similar to the one of Proposition 3.2.) Hence, we may apply  $Enz_{xy}$  and get

$$[(l_m \oplus \underline{x})f] \uparrow^{i(\underline{x})} \sim [(l_m \oplus \underline{x}')f'] \uparrow^{i(\underline{x}')}$$

□

The simulation relation is compatible with the operations in  $\text{NF}\ell[X, T]$ , more precisely:

**Proposition 7.16** *(simulation is a congruence)*

*Assume  $T$  is an  $a\alpha$ -flow and  $F_1 \rightarrow_u F_2$  and  $F'_1 \rightarrow_{u'} F'_2$  are two simulations in  $\text{NF}\ell[X, T]$ .*

*Then:*

$$(a) \quad F_1 \oplus F'_1 \rightarrow_{u \oplus u'} F_2 \oplus F'_2$$

$$(b) \quad F_1 \cdot F'_1 \rightarrow_{u \oplus u'} F_2 \cdot F'_2$$

$$(c) \quad F_1 \uparrow^p \rightarrow_u F_2 \uparrow^p$$

*whenever the operations have sense.*<sup>5</sup>

The relation of simulation is reflexive, transitive and compatible with the operations, but, unfortunately, it is not symmetric in almost all cases.<sup>6</sup> Consequently the following result holds.

---

<sup>5</sup>From all the axioms of feedback only the axiom R7 of commutation of feedback with composition is used here.

<sup>6</sup>It is symmetric only in case  $a\alpha$ .

**Proposition 7.17** *The congruence  $\overset{xy}{\longleftrightarrow}$  generated by simulation  $\overset{xy}{\longrightarrow}$  is*

$$\overset{xy}{\longleftrightarrow} = \text{Trans}(\text{Sym}(\overset{xy}{\longrightarrow})) = (\overset{xy}{\longrightarrow} \circ \overset{xy}{\longleftarrow})^+ = (\overset{xy}{\longleftarrow} \circ \overset{xy}{\longrightarrow})^+,$$

where  $\overset{xy}{\longleftarrow}$  denotes  $(\overset{xy}{\longrightarrow})^{-1}$  and  $R^+$  denotes the transitive closure of a relation  $R$ .  $\square$

**Notation 7.18**  $\text{n-xyf}(\mathbb{F}\ell_{xy}[X, T])$   $\mathbb{F}\ell_{xy}[X, T]$  denotes  $\text{NF}\ell[X, T]/\overset{xy}{\longleftrightarrow}$ .  $\square$

Since in the proof of Theorem 7.9 the Enz rule was applied only one time, the result still holds when enzymatic rule is replaced by simulation. Hence:

**Corollary 7.19** *Let  $T$  be an  $\alpha\alpha$ -flow and a strong  $xy$ -ssmc.*

*Then  $\text{NF}\ell[X, T]/\overset{xy}{\longleftrightarrow}$  is an  $\alpha\alpha$ -flow and a strong  $xy$ -ssmc, too.  $\square$*

This corollary shows that a part of the converse implication to that in Proposition 7.15 holds, i.e.

“if  $\sim$  the equivalence generated by simulation with  $xy$ -morphisms, then  $(C_{xy}\text{-var})$  holds in  $\text{NF}\ell[X, T]/\sim$ ”.

It may be interesting to see when the other part of the implication holds, i.e.

“if  $\sim$  is the equivalence generated by simulation with  $xy$ -morphisms, does  $\text{Enz}_{xy}$  hold in  $\text{NF}\ell[X, T]/\sim$ ?”.

This question actually means to look for conditions such that the generative process displayed in Proposition 7.8 stops in one step when it is applied to Enz. A partial answer is given in the Lemma 7.21 below.

**Lemma 7.20** ( *$\rightarrow$  preserves enzymatic rule*)

*If  $\text{Enz}_{\{j\}}$  holds in  $T$ , then simulation  $\rightarrow$  obeys  $\text{Enz}_{\{j\}}$  in  $\text{NF}\ell[X, T]$ .*

*More precisely, the implications*

$$\begin{aligned} (a) \quad F \cdot (l_n \oplus j) &\xrightarrow{u} (l_m \oplus j) \cdot G \quad \Rightarrow \quad F \uparrow^p \xrightarrow{u} G \uparrow^q \\ (b) \quad F \cdot (l_n \oplus j) &\xleftarrow{u} (l_m \oplus j) \cdot G \quad \Rightarrow \quad F \uparrow^p \xleftarrow{u} G \uparrow^q \end{aligned}$$

hold for every  $f \in \text{NF}\ell[X, T](m \oplus p, n \oplus p)$ ,  $G \in \text{NF}\ell[X, T](m \oplus q, n \oplus q)$  and  $j : p \rightarrow q$ .

**Proof:** a) Suppose  $F = (\underline{x}, f)$  and  $G = (\underline{y}, g)$  with  $\underline{x}, \underline{y} \in X^*$ . The simulation gives

$$f \cdot (l_n \oplus j \oplus i(u)) = (l_m \oplus j \oplus o(u)) \cdot g$$

This implies

$$\begin{aligned} &[(l_m \oplus {}^{o(\underline{x})}\mathbf{X}^p) \cdot f \cdot (l_n \oplus {}^p\mathbf{X}^{i(\underline{x})}) \cdot (l_n \oplus i(u) \oplus l_p)] \cdot (l_{n \oplus i(\underline{y})} \oplus j) \\ &= (l_{m \oplus o(\underline{x})} \oplus j) \cdot [(l_m \oplus o(u) \oplus l_q) \cdot (l_m \oplus {}^{o(\underline{y})}\mathbf{X}^q) \cdot g \cdot (l_n \oplus {}^q\mathbf{X}^{i(\underline{y})})] \end{aligned}$$

Applying  $\text{Enz}_{\{j\}}$  in  $T$  we get

$$\begin{aligned} &[(l_m \oplus {}^{o(\underline{x})}\mathbf{X}^p) \cdot f \cdot (l_n \oplus {}^p\mathbf{X}^{i(\underline{x})})] \uparrow^p \cdot (l_n \oplus i(u)) \\ &= (l_m \oplus o(u)) \cdot [(l_m \oplus {}^{o(\underline{y})}\mathbf{X}^q) \cdot g \cdot (l_n \oplus {}^q\mathbf{X}^{i(\underline{y})})] \uparrow^q \end{aligned}$$

This shows that

$$F \uparrow^p \xrightarrow{u} G \uparrow^q$$

(b) Similar.  $\square$

**Lemma 7.21** *Suppose we are given some restrictions  $A, B, C, D$ , a morphism  $j \in T(p, q)$  and two pairs  $F \in \text{NF}\ell[X, T](m \oplus p, n \oplus p)$ ,  $G \in \text{NF}\ell[X, T](m \oplus q, n \oplus q)$ . Suppose moreover the following conditions hold:*

$$(1) F \cdot (l_n \oplus j) \xleftarrow{B} \circ \xrightarrow{C} \circ \xleftarrow{D} (l_m \oplus j) \cdot G \quad \text{and} \quad A \supseteq B \cup C \cup D;$$

$$(2) F \cdot (l_n \oplus j) \xleftarrow{u} H_1 \quad \Rightarrow \quad \exists H'_1 : H_1 = H'_1 \cdot (l_n \oplus j) \ \& \ F \xleftarrow{u} H'_1$$

*for  $u$  obeying restriction  $B$  and arbitrary  $H_1$ ;*

$$(3) H_2 \xleftarrow{u} (l_m \oplus j) \cdot G \quad \Rightarrow \quad \exists H'_2 : H_2 = (l_m \oplus j) \cdot H'_2 \ \& \ H'_2 \xleftarrow{u} G$$

*for  $u$  obeying restriction  $D$  and arbitrary  $H_2$*

then

$$\text{if } \text{Enz}_{\{j\}} \text{ holds in } T, \quad \text{then } \text{Enz}_{j, F, G} \text{ holds in } \text{NF}\ell[X, T] / \xleftrightarrow{A}.$$

**Proof:** Using (1) we get

$$F \cdot (l_n \oplus j) \xleftarrow{B} H_1 \xrightarrow{C} H_2 \xleftarrow{D} (l_m \oplus j) \cdot G$$

Using (2) for the left simulation we get a pair  $H'_1$  such that  $H_1 = H'_1 \cdot (l_n \oplus j)$  and  $F \xleftarrow{B} H'_1$ , hence

$$F \uparrow^p \xleftarrow{B} H'_1 \uparrow^p$$

Applying (3) to the right simulation we get a pair  $H'_2$  such that  $H_2 = (l_m \oplus j) \cdot H'_2$  and  $H'_2 \xleftarrow{D} G$ , hence

$$H'_2 \uparrow^q \xleftarrow{D} G \uparrow^q$$

Now the middle simulation may be written as

$$H'_1 \cdot (l_n \oplus j) \xrightarrow{C} (l_m \oplus j) \cdot H'_2$$

hence we may apply Lemma 7.20 (a) to get

$$H'_1 \uparrow^p \xrightarrow{C} H'_2 \uparrow^q$$

All these observations show that

$$F \uparrow^p \xleftarrow{B} H'_1 \uparrow^p \xrightarrow{C} H'_2 \uparrow^q \xleftarrow{D} G \uparrow^q$$

hence

$$F \uparrow^p \xrightarrow{A} G \uparrow^q$$

□

### 7.3.3 Duality

The duality studied in the acyclic case (Definition 2.14) may be extended to the cyclic case by using the duality rule:

$$(f \uparrow^p)^o = (f^o) \uparrow^p, \quad \text{for } f : m \oplus p \rightarrow n \oplus p.$$

The dual expression corresponding to a flownomial expression

$$F = [(l_m + x) \cdot f] \uparrow^{i(x)} : m \rightarrow n$$

is a flownomial expression

$$F^o : n \rightarrow m \quad \text{in} \quad (\mathbb{F}\ell_{EXP}[X^o, T^o], \oplus, \odot, \uparrow, \downarrow, \times)$$

where

- $X^o(m, n) = \{x^o : x \in X(n, m)\}$ ,  
hence in  $X^o$  the functions  $i^o, o^o : X^o \rightarrow \mathbb{N}$  which specify the inputs and the outputs, respectively, are obtained by interchanging the ones of  $X$ , i.e.  $i^o(x^o) = o(x)$  and  $o^o(x^o) = i(x)$ , and
- $(T^o, \oplus, \odot, \uparrow, \downarrow, \times)$  is the dual theory associated to  $T$ .

Namely,

$$\begin{aligned} F^o &= (((l_m \oplus x) \cdot f) \uparrow^{i(x)})^o \\ &= ((l_m \oplus x) \cdot f)^o \uparrow^{i(x)} \\ &= (f^o \odot (l_m \oplus x^o)) \uparrow^{o^o(x^o)} \\ &= ((l_n \oplus x^o) \odot f^o) \uparrow^{i^o(x^o)} \quad \text{by R9} \end{aligned}$$

Written for pairs, the duality means

$$(x, f)^o = (x^o, f^o)$$

Finally, let us see what we get by dualising a simulation

$$F = (x, f) \rightarrow_u G = (y, g)$$

The simulation means

$$f \cdot (l_n \oplus i(u)) = (l_m \oplus o(u)) \cdot g$$

and by duality this gives

$$(l_n \oplus i^o(u^o)) \odot f^o = g^o \odot (l_m \oplus o^o(u^o))$$

Hence

$$F^o = (x^o, f^o) \xrightarrow{u^o} G^o = (y^o, g^o)$$

It is clear that if  $u$  obeys a restriction  $xy$ , the  $u^o$  obeys the dual restriction  $(xy)^o$ . Consequently,

**Fact 7.22** *By duality a simulation changes its sense and its restriction is replaced by the dual one.  $\square$*

## 7.4 Short comments and references

This chapter is a technical one. It is based on Chapter C of [Ste91].

The enzymatic rule via general functions is used in [ArM80] under the name ‘functoriality rule’, a name which was also used in our previous papers. In an implicit way the enzymatic rule for functions appear in the axiomatization of iteration theories in [Esi80, BlEs93a].

The simulation relation we are using here has the roots in the corresponding equivalence relations used in [Gog74, Elg77] where a kind of simulation via functions is present. Simulations via various classes of relations are used in [Ste87a, Ste87b, CaS90a]. In a more abstract setting they are present in [CaS92].

The example in section 7.1.1 is from [CaS92].

# Chapter 8

## Deterministic one-way behaviour ( $a\delta$ -flow)

The one-way behaviour we are studying here is “half” of the standard input-output behaviour. It may be described as follows.

Suppose the behaviour of the many-inputs/many-outputs objects is given by tuples of single-input/many-outputs ones. Then the set of all step-by-step computation sequences associated to a (single-input) flowgraph may be described using the regular tree obtained by a completely unfolding of the given flowgraph. Two flowgraphs are considered equivalent here iff they unfold into the same tuple of trees.

The main result of this chapter shows that the  $a\delta$ -flow structure gives a correct and complete axiomatisation of flowgraphs modulo this equivalence. Consequently, in order to cope with the axiomatisation of the classes of one-way equivalent flowgraphs one has to add to the axiomatisation of flowgraphs modulo graph-isomorphism a few simple axioms: the strong axioms and the enzymatic rule for functions.

The proofs are given in the abstract setting, namely in the case the theory for connections is an arbitrary  $a\delta$ -flow.

### 8.1 Characterization theorem $\overset{a\delta}{\longleftrightarrow}$ ; ( $\overset{a\delta}{\longleftrightarrow}$ -minimization)

In what follows we prove a characterization theorem for the equivalence relation generated by simulation via functions, namely

$$\overset{a\delta}{\longleftrightarrow} = \overset{a\gamma}{\rightarrow} \circ \overset{a\beta}{\leftarrow} \circ \overset{a\beta}{\rightarrow} \circ \overset{a\gamma}{\leftarrow}$$

This means that

two flowgraphs are  $\overset{a\delta}{\longleftrightarrow}$ -equivalent

if and only if by

- (1) reduction (i.e. by identification of vertices that have the same label and whose outgoing connections become identical after identification) and
- (2) deletion of vertices with no incoming paths from the entries (= nonaccessible)

Table 8.1: Is  $x \circ y \subseteq y \circ x$ ? (case  $a\delta$ )

$\begin{array}{c} y \\ x \end{array}$	$\xrightarrow{a\gamma}$	$\xleftarrow{a\beta}$	$\xrightarrow{a\beta}$	$\xleftarrow{a\gamma}$
$\xrightarrow{a\gamma}$	Obvious			
$\xleftarrow{a\beta}$	8.4	Obvious		
$\xrightarrow{a\beta}$	8.1	8.3	Obvious	
$\xleftarrow{a\gamma}$	8.6	8.2	8.5	Obvious

both flowgraphs may be brought to the same form.

The context for proving this theorem is that of an algebraic theory  $T$  endowed with a feedback operation. So that  $T$  is supposed to be an  $a\delta$ -strong  $b\delta$ -ssmc. The core of the proof is given by the commuting relations between the elementary simulations  $\xrightarrow{a\beta}$ ,  $\xrightarrow{a\gamma}$  and their converses. (See Table 8.1) We also suppose here that the flowgraphs we use are in  $\text{NFL}[X, T](m, n)$ , for some  $m, n \in M$ .

**Lemma 8.1**  $\xrightarrow{a\beta} \circ \xrightarrow{a\gamma} \subseteq \xrightarrow{a\delta} \subseteq \xrightarrow{a\gamma} \circ \xrightarrow{a\beta}$ , when  $T$  is a  $b\delta$ -ssmc.

**Proof:** The first inclusion obviously holds true.

For the second one, suppose we are given two similar pairs

$$F' = (x', f') \xrightarrow{a\delta}_u F'' = (x'', f'')$$

This means

$$(1) \quad f' (l_n \oplus i(u)) = (l_m \oplus o(u)) f''$$

Function  $u \in a\delta\text{-IRel}_X(x', x'')$  may be written as a composite of a surjection and an injection, say

$$u = u_s \cdot u_i$$

with  $u_s \in a\gamma\text{-IRel}_X(x', x)$  and  $u_i \in a\beta\text{-IRel}_X(x, x'')$ . Then there exist a function  $v_s \in a\delta\text{-IRel}_X(x, x')$  such that  $v_s \cdot u_s = l_x$  and an (eventually partial) function  $v_i : x'' \rightarrow x$  such that  $u_i \cdot v_i = l_x$ .

Take the pair

$$F = (x, f) \quad \text{with} \quad f = (l_m \oplus o(v_s)) f' (l_n \oplus i(u_s))$$

We show that

$$F' \xrightarrow{u_s} F \xrightarrow{u_i} F''$$

Indeed, the left relation gives a simulation by

---

<sup>1</sup>The function  $v_i$  is partial in the case  $x''$  contains some letters that does not occur in  $x$ .



$$\begin{aligned}
(l_m \oplus o(u_s)) \cdot f &= (l_m \oplus o(u_s v_s)) f' (l_n \oplus i(u_s)) && \text{def } f \\
&= (l_m \oplus o(u_s v_s)) f' (l_n \oplus i(u_s u_i v_i)) \\
&= (l_m \oplus o(u_s v_s)) f' (l_n \oplus i(u)) (l_n \oplus i(v_i)) \\
&= (l_m \oplus o(u_s v_s u)) f'' (l_n \oplus i(v_i)) && \text{by (1)} \\
&= (l_m \oplus o(u_s u_i)) f'' (l_n \oplus i(v_i)) \\
&= f' \cdot (l_n \oplus i(u v_i)) && \text{by (1)} \\
&= f' \cdot (l_n \oplus i(u_s))
\end{aligned}$$

and the right one by

$$\begin{aligned}
f \cdot (l_n \oplus i(u_i)) &= (l_m \oplus o(v_s)) f' (l_n \oplus i(u_s u_i)) && \text{def } f \\
&= (l_m \oplus o(u_i)) \cdot f'' && \text{by (1)}
\end{aligned}$$

□

Using the converse relations we get

$$\textbf{Lemma 8.2} \quad \xleftarrow{a\gamma} \circ \xleftarrow{a\beta} \subseteq \xleftarrow{a\delta} \subseteq \xleftarrow{a\beta} \circ \xleftarrow{a\gamma}, \quad \text{when } T \text{ is a } b\delta\text{-ssmc.} \quad \square$$

$$\textbf{Lemma 8.3} \quad \xrightarrow{a\beta} \circ \xleftarrow{a\beta} \subseteq \xleftarrow{a\beta} \circ \xrightarrow{a\beta}, \quad \text{when } T \text{ is a } b\delta\text{-ssmc.}$$

**Proof:** Suppose

$$F' \xrightarrow{a\beta}_{u'} F \xleftarrow{a\beta}_{u''} F''$$

Using isomorphic representations for  $F'$ ,  $F$  and  $F''$  we may suppose that

$$\begin{aligned}
F' &= (a \oplus b, f'), \quad F = (a \oplus b \oplus c \oplus d, f), \quad F'' = (b \oplus c, f'') \\
u' &= l_{a \oplus b} \oplus \top_{c \oplus d} \text{ and } u'' = \top_a \oplus l_{b \oplus c} \oplus \top_d
\end{aligned}$$

The simulations show that

$$\begin{aligned}
(1) \quad f' \cdot (l_n \oplus i(l_{a \oplus b} \oplus \top_{c \oplus d})) &= (l_m \oplus o(l_{a \oplus b} \oplus \top_{c \oplus d})) \cdot f \quad \text{and} \\
(2) \quad f'' \cdot (l_n \oplus i(\top_a \oplus l_{b \oplus c} \oplus \top_d)) &= (l_m \oplus o(\top_a \oplus l_{b \oplus c} \oplus \top_d)) \cdot f
\end{aligned}$$

Take the pair

$$\overline{F} = (b, \overline{f}) \quad \text{with} \quad \overline{f} = (l_m \oplus o(\top_a \oplus l_b \oplus \top_{c \oplus d})) \cdot f \cdot (l_n \oplus i(\perp^a \oplus l_b \oplus \perp^{c \oplus d}))$$

We show that

$$F' \xrightarrow{\top_a \oplus l_b} \xleftarrow{a\beta} \overline{F} \xrightarrow{a\beta} \xrightarrow{l_b \oplus \top_c} F''$$

Indeed, in the left part we have a simulation since

$$\begin{aligned}
&\overline{f} \cdot (l_n \oplus i(\top_a \oplus l_b)) \\
&= (l_m \oplus o(\top_a \oplus l_b \oplus \top_{c \oplus d})) \cdot f \cdot (l_n \oplus i(\perp^a \cdot \top_a \oplus l_b \oplus \perp^{c \oplus d})) && \text{def } \overline{f} \\
&= (l_m \oplus o(l_b \oplus \top_c)) \cdot f'' \cdot (l_n \oplus i(\top_a \oplus l_{b \oplus c} \oplus \top_d) \cdot i(\perp^a \cdot \top_a \oplus l_b \oplus \perp^{c \oplus d})) && \text{by (2)} \\
&= (l_m \oplus o(l_b \oplus \top_c)) \cdot f'' \cdot (l_n \oplus i(\top_a \oplus l_{b \oplus c} \oplus \top_d) \cdot i(l_a \oplus l_b \oplus \perp^{c \oplus d})) \\
&= (l_m \oplus o(\top_a \oplus l_b \oplus \top_{c \oplus d})) \cdot f \cdot (l_n \oplus i(l_{a \oplus b} \oplus \perp^{c \oplus d})) && \text{by (2)} \\
&= (l_m \oplus o(\top_a \oplus l_b)) \cdot f' \cdot (l_n \oplus i(l_{a \oplus b} \oplus \top_{c \oplus d}) \cdot i(l_{a \oplus b} \oplus \perp^{c \oplus d})) && \text{by (1)} \\
&= (l_m \oplus o(\top_a \oplus l_b)) \cdot f'
\end{aligned}$$

and in a similar way one may prove that in the right part we have a simulation, too.  $\square$

**Lemma 8.4**  $\xleftarrow{a\beta} \circ \xrightarrow{a\gamma} \subseteq \xrightarrow{a\gamma} \circ \xleftarrow{a\beta}$ , when  $T$  is an  $a\delta$ -strong  $b\delta$ -ssmc.

**Proof:** Let

$$F' \xleftarrow{u'} \xleftarrow{a\beta} F \xrightarrow{a\gamma} \xrightarrow{u''} F''$$

Using an isomorphic copy of  $F'$  we may suppose

$$F' = (a \oplus b, f'), \quad F = (a, f) \quad \text{and} \quad u' = l_a \oplus \top_b$$

Let  $F'' = (c, f'')$ . The simulations give

- (1)  $f \cdot (l_n \oplus i(l_a \oplus \top_b)) = (l_m \oplus o(l_a \oplus \top_b)) \cdot f'$  and
- (2)  $f \cdot (l_n \oplus i(u'')) = (l_m \oplus o(u'')) \cdot f''$

Take the pair

$$\overline{F} = (c \oplus b, \overline{f})$$

where

$$\overline{f} = (f'' (l_n \oplus i(l_c \oplus \top_b)) \oplus (\top_m \oplus o(\top_a \oplus l_b)) f' (l_n \oplus i(u'' \oplus l_b))) \cdot \vee_{n \oplus i(c \oplus b)}$$

We show that

$$F' \xrightarrow{a\gamma} \xrightarrow{u' \oplus l_b} \overline{F} \xleftarrow{l_c \oplus \top_b} \xleftarrow{a\beta} F''$$

Indeed, for the left part we may compute

$$\begin{aligned} & (l_m \oplus o(u'' \oplus l_b)) \cdot \overline{f} \\ &= [(l_m \oplus o(u'')) f'' (l_n \oplus i(l_c \oplus \top_b)) \\ & \quad \oplus (\top_m \oplus o(\top_a \oplus l_b)) f' (l_n \oplus i(u'' \oplus l_b))] \cdot \vee_{n \oplus i(c \oplus b)} && \text{def } \overline{f} \\ &= [f (l_n \oplus i(u'' \oplus \top_b)) \\ & \quad \oplus (\top_m \oplus o(\top_a \oplus l_b)) f' (l_n \oplus i(u'' \oplus l_b))] \cdot \vee_{n \oplus i(c \oplus b)} && \text{by (2)} \\ &= [(l_m \oplus o(l_a \oplus \top_b)) f' (l_n \oplus i(u'' \oplus l_b)) \\ & \quad \oplus (\top_m \oplus o(\top_a \oplus l_b)) f' (l_n \oplus i(u'' \oplus l_b))] \cdot \vee_{n \oplus i(c \oplus b)} && \text{by (1)} \\ &= f' \cdot (l_n \oplus i(u'' \oplus \top_b)) && \text{by (C}_{a\gamma}\text{-mor)} \end{aligned}$$

and for the right part the computation is

$$\begin{aligned} & (l_m \oplus o(l_c \oplus \top_b)) \cdot \overline{f} \\ &= [f'' (l_n \oplus i(l_c \oplus \top_b)) \\ & \quad \oplus (\top_m \oplus o(\top_a \oplus \top_b)) f' (l_n \oplus i(u'' \oplus l_b))] \cdot \vee_{n \oplus i(c \oplus b)} && \text{def } \overline{f} \\ &= (f'' (l_n \oplus i(l_c \oplus \top_b))) && \text{by (C}_{a\beta}\text{-mor)} \end{aligned}$$

$\square$

Using the converse relations we have

**Lemma 8.5**  $\xleftarrow{a\gamma} \circ \xrightarrow{a\beta} \subseteq \xrightarrow{a\beta} \circ \xleftarrow{a\gamma}$ , when  $T$  is an  $a\delta$ -strong  $b\delta$ -ssmc.  $\square$

**Lemma 8.6**  $\xleftarrow{a\gamma} \circ \xrightarrow{a\gamma} \subseteq \xrightarrow{a\gamma} \circ \xleftarrow{a\gamma}$ , when  $T$  is an  $a\delta$ -strong  $b\delta$ -ssmc.

**Proof:** Suppose

$$F' \xleftarrow{u'} F \xrightarrow{u''} F''$$

where  $F' = (x', f')$ ,  $F = (x, f)$  and  $F'' = (x'', f'')$ . It follows that

- (1)  $f \cdot (l_n \oplus i(u')) = (l_m \oplus o(u')) \cdot f'$  and
- (2)  $f \cdot (l_n \oplus i(u'')) = (l_m \oplus o(u'')) \cdot f''$

For a funnction  $g : p \rightarrow q$  we denote by

$$Ker(g) = \{(j, k) : j, k \in [p] \text{ and } g(j) = g(k)\}$$

Let  $\sim$  be the least equivalence relation on  $[[x]]$  which contain both  $Ker(u')$  and  $Ker(u'')$ . By Observation 7.7,  $\sim$  may be constructively defined by

$$j \sim k \Leftrightarrow \begin{cases} \text{there exists a sequence of elements in } [[x]] \text{ denoted by} \\ n_1, \dots, n_r \text{ with } n_1 = j \text{ and } n_r = k, \text{ such that} \\ (n_s, n_{s+1}) \in Ker(u') \cup Ker(u''), \text{ for every } s < r \end{cases}$$

Relation  $\sim$  inherits from  $Ker(u')$  and  $Ker(u'')$  the property that it does not identify elements  $j, k \in [[x]]$  with  $x_j \neq x_k$ . Hence  $\sim$  may be represented as

$$\sim = Ker(u)$$

for a  $u \in a\gamma\text{-IRel}_X(x, \bar{x})$ . Let  $z' : x' \rightarrow \bar{x}$  and  $z'' : x'' \rightarrow \bar{x}$  denote the induced multisorted surjections which satisfy the condition

$$u' \cdot z' = u = u'' \cdot z''$$

For  $j \in [[x]]$  denote by  $f_j$  the component of  $f$  corresponding to the outputs of  $x_j$ , i.e.

$$f_j = (\top_{m \oplus o(x_1 \oplus \dots \oplus x_{j-1})} \oplus l_{o(x_j)} \oplus \top_{o(x_{j+1} \oplus \dots \oplus x_{|x|})}) \cdot f$$

The simulations  $u'$  and  $u''$  show that

- $(j, k) \in Ker(u')$   $\Rightarrow f_j \cdot (l_n \oplus i(u')) = f_k \cdot (l_n \oplus i(u'))$  and
- $(j, k) \in Ker(u'')$   $\Rightarrow f_j \cdot (l_n \oplus i(u'')) = f_k \cdot (l_n \oplus i(u''))$

respectively. Using  $u' \cdot z' = u = u'' \cdot z''$  we get

$$(j, k) \in Ker(u') \cup Ker(u'') \Rightarrow f_j \cdot (l_n \oplus i(u)) = f_k \cdot (l_n \oplus i(u))$$

and this implication may easily be extended to  $(j, k) \in Ker(u)$  using the above constructive definition of  $Ker(u)$  ( $= \sim$ ). This shows that

$$(*) \quad f \cdot (l_n \oplus i(u)) = (l_m \oplus o(u \cdot v)) \cdot f \cdot (l_n \oplus i(u)), \text{ for every } v \text{ with } v \cdot u = l_{\bar{x}}.$$

Now we construct a pair

$$\overline{F} = (\overline{x}, \overline{f}) \quad \text{with} \quad \overline{f} = (l_m \oplus o(v)) \cdot f \cdot (l_n \oplus i(u))$$

where  $v \in a\beta\text{-Rel}_X(\overline{x}, x)$  is a right inverse for  $u$ , i.e.  $v \cdot u = l_{\overline{x}}$ .

With this definition of  $\overline{F}$  we may prove that

$$F' \xrightarrow{a\gamma}_{z'} \overline{F} \xleftarrow{a\gamma}_{z''} F''$$

Indeed, for the left simulation, take a  $v' \in a\beta\text{-Rel}_X(x', x)$  such that  $v' \cdot u' = l_{x'}$ . Then

$$\begin{aligned} f' \cdot (l_m \oplus i(z')) &= (l_m \oplus o(v' \cdot u')) f' (l_n \oplus i(z')) \\ &= (l_m \oplus o(v')) f (l_n \oplus i(u' \cdot z')) && \text{by (1)} \\ &= (l_m \oplus o(v')) f (l_n \oplus i(u)) \\ &= (l_m \oplus o(v' \cdot u \cdot v)) f (l_n \oplus i(u)) && \text{by (*)} \\ &= (l_m \oplus o(z')) (l_m \oplus o(v)) f (l_n \oplus i(u)) && \text{by } v'u = v'u'z' = z' \\ &= (l_m \oplus o(z')) \cdot \overline{f} && \text{def } \overline{f} \end{aligned}$$

For the right simulation the computation is similar.  $\square$

Combining the above lemmas we get the following result.

**Theorem 8.7** (*characterization theorem for  $\xleftrightarrow{a\delta}$* )

Let  $T$  be an  $a\delta$ -strong  $b\delta$ -ssmc endowed with a feedback operation. Then the following equality holds in  $\text{NF}\ell[X, T]$ :

$$\xleftrightarrow{a\delta} = \xrightarrow{a\gamma} \circ \xleftarrow{a\beta} \circ \xrightarrow{a\beta} \circ \xleftarrow{a\gamma} .$$

**Proof:** We know that  $\xrightarrow{a\gamma}$ ,  $\xrightarrow{a\beta}$ ,  $\xleftarrow{a\gamma}$  and  $\xleftarrow{a\beta}$  are reflexive and transitive relations. Moreover, from Lemmas 8.1 and 8.2 it follows that

$$\xrightarrow{a\delta} \subseteq \xrightarrow{a\gamma} \cdot \xrightarrow{a\beta} \quad \text{and} \quad \xleftarrow{a\delta} \subseteq \xleftarrow{a\gamma} \cdot \xleftarrow{a\beta}$$

respectively. Hence

$$F \xleftrightarrow{a\delta} F' \quad \text{iff} \quad \exists n \geq 0 : F \rho^n F'$$

where  $\rho = \xrightarrow{a\gamma} \circ \xleftarrow{a\beta} \circ \xrightarrow{a\beta} \circ \xleftarrow{a\gamma}$ . Using the commuting lemmas 8.1–8.6, it follows that all the relations  $\rho \circ \xrightarrow{a\gamma}$ ,  $\rho \circ \xrightarrow{a\beta}$ ,  $\rho \circ \xleftarrow{a\gamma}$  and  $\rho \circ \xleftarrow{a\beta}$  are included in  $\rho$ , hence  $\rho$  is a transitive relations. This gives

$$\xleftrightarrow{a\delta} = \rho$$

$\square$

The minimization of flowgraphs with respect to the  $\xleftrightarrow{a\delta}$ -equivalence is based on the above theorem. First we give some definitions.

**Definition 8.8** (isomorphic and minimal pairs; reductions)

- Given an equivalence relation  $\sim$  on pairs we say the pair  $(x, f)$  is  $\sim$ -minimal if there is no  $(x', f') \sim (x, f)$  with  $|x'| < |x|$ .
- The relations  $\xrightarrow{a\gamma}$  and  $\xleftarrow{a\beta}$  are *reductions*, i.e. if  $(x, f) \xrightarrow{a\gamma} (x', f')$  or  $(x, f) \xleftarrow{a\beta} (x', f')$  then  $|x'| < |x|$ .
- The relation  $\xrightarrow{a\alpha}$  is also called *isomorphism*.

□

Now the following corollaries may be obtained.

**Corollary 8.9** *Two  $\xleftrightarrow{a\delta}$ -minimal and equivalent pairs are isomorphic.* □

**Corollary 8.10** *A pair  $F$  is  $\xleftrightarrow{a\delta}$ -minimal if and only if  $(F \xrightarrow{a\gamma} F'$  and  $F \xleftarrow{a\beta} F')$  implies  $F \xrightarrow{a\alpha} F'$ .* □

## 8.2 The input behaviour

**Definition 8.11** (input behaviour; — deterministic case)

A flowgraph may use blocks with multiple-entries/multiple-exits. We suppose here that their meaning may be specified by tuples of single-entry elements, hence we are working in an algebraic theory. Consequently, we may replace all the variables with one-entry/multiple-exits variables.

For an input into the flowgraph let us consider the unfoldment of the flowgraph into tree starting from the specified input. Such a tree is called a *regular (or finit index) tree*.

Finally, by the *input (step-by-step) behaviour of the flowgraph* we mean the tuple of the regular trees obtained as above for each input. □

How may one get an algebraic calculus for this kind of behaviour of flowgraphs? Our answer in the  $a\delta$ -Flow-Calculus, defined below in a more abstract setting.

**Definition 8.12** ( $xy$ -Flow-Calculus;  $xy$ -flownomials)

Let  $x \in \{a, b, c, d\}$  and  $y \in \{\alpha, \beta, \gamma, \delta\}$ .

1. The  $xy$ -Flow-Calculus is the calculus obtained from the  $a\alpha$ -Flow-Calculus corresponding to flowgraphs by adding:
  - the conditions of commutation of  $xy$ -constants with arbitrary morphisms (i.e.  $C_{xy}$ -mor in Table 3.1) and
  - the enzymatic rule for the looping operation corresponding to  $xy$ -morphisms (i.e.  $\text{Enz}_{xy}$  defined in Definition 7.2).
2. An  $xy$ -flownomial is a class of flownomial expressions corresponding to  $\sim_{xy}$ , where  $\sim_{xy}$  is the congruence relation with property  $\text{Enz}_{xy}$  generated by the relation  $C_{xy}$ -var in Table 7.1.

□

**Theorem 8.13** (see for example [Ste87a])

*The algebra  $R[X]$  of regular trees over  $X$  is isomorphic to the algebra of  $\mathbb{F}\ell_{a\delta}[X, \text{Pfn}]$  of  $\xleftrightarrow{a\delta}$ -minimal flowgraphs.* □

## 8.3 Correctness of $a\delta$ -Flow-Calculus

### 8.3.1 Extending $a\delta$ -flow structure form $T$ to $\mathbb{F}\ell_{a\delta}[X, T]$

Theorem 8.7 may be used to prove that the equivalence relation generated by simulation via functions satisfies the enzymatic rule. Before this, we simplify a bit the enzymatic axiom in this particular case.

**Proposition 8.14** *In an  $a\alpha$ -flow over an algebraic theory (i.e over a strong  $a\delta$ -ssmc) axiom  $\text{Enz}_{a\beta}$  holds.*

**Proof:** According to Lemma 7.10 it is enough to show that  $\text{Enz}_{\{\top_q\}}$  holds for an arbitrary  $q$ . Suppose  $f : m \rightarrow n$  and  $g : m \oplus q \rightarrow n \oplus q$  are such that

$$(1) \quad f \cdot (l_n \oplus \top_q) = (l_m \oplus \top_q) \cdot g$$

Then

$$\begin{aligned} g \uparrow^q &= ((l_m \oplus \top_q \oplus \top_m \oplus l_q) \cdot \vee_{m \oplus q} \cdot g) \uparrow^q \\ &= (((l_m \oplus \top_q) g \oplus (\top_m \oplus l_q) g) \cdot \vee_{n \oplus q}) \uparrow^q && \text{by } (C_{a\gamma}\text{-mor}) \\ &= ((f (l_n \oplus \top_q) \oplus (\top_m \oplus l_q) g) \cdot \vee_{n \oplus q}) \uparrow^q && \text{by } (1) \\ &= ((f \oplus l_q) \cdot (l_n \oplus (\top_m \oplus l_q) g) \cdot (l_n \oplus \top_q \oplus l_{n \oplus q}) \cdot \vee_{n \oplus q}) \uparrow^q \\ &= f \cdot ((l_n \oplus (\top_m \oplus l_q) g) \cdot (\vee_n \oplus l_q)) \uparrow^q \\ &= f \cdot (l_n \oplus \top_m \cdot (g \uparrow^q)) \cdot \vee_n \\ &= f \cdot (l_n \oplus \top_n) \cdot \vee_n && \text{by } (C_{a\beta}\text{-mor}) \\ &= f \\ &= f \uparrow^0 \end{aligned}$$

□

Using this proposition and Theorem 8.7 we get

**Theorem 8.15** *It  $T$  is an  $a\delta$ -flow, then in  $\mathbb{F}\ell[X, T]$  the relation  $\overset{a\delta}{\iff}$  fulfils  $\text{Enz}_{a\delta}$ .*

**Proof:** Corollary 7.19 shows that  $\mathbb{F}\ell[X, T] / \overset{a\delta}{\iff}$  is an  $a\alpha$ -flow over an algebraic theory. By the above it obeys  $\text{Enz}_{\{\top_q\}}$ . Up to a composition with some bijections, every  $a\delta$ -morphism is a sum of elements of the type  $\vee_p^k$ ,  $k \geq 0$ . Finally, by using Lemma 7.10 the problem is reduced to the verification of  $\text{Enz}_u$  for  $u = \vee_p^k$  and  $k \geq 2$ .

Let  $F \in \mathbb{F}\ell[X, T](m \oplus kp, n \oplus kp)$  and  $G \in \mathbb{F}\ell[X, T](m \oplus p, n \oplus p)$  be such that

$$F \cdot (l_n \oplus \vee_p^k) \overset{a\delta}{\iff} (l_m \oplus \vee_p^k) \cdot G$$

We may suppose that  $G = (\underline{x}, g)$  is an  $\overset{a\delta}{\iff}$ -minimal pair. It follows that  $(l_m \oplus \vee_p^k) \cdot G$  is minimal, too:

Indeed, suppose  $(l_m \oplus \vee_p^k) \cdot G$  is not minimal. Then, it has an effective reduction  $(l_m \oplus \vee_p^k) \cdot G \xrightarrow{a\gamma} H$  or  $(l_m \oplus \vee_p^k) \cdot G \xleftarrow{a\beta} H$  for an  $H = (y, h)$  with  $|y| < |x|$ . By a left composition with  $l_m \oplus (l_p \oplus \top_{(k-1)p})$  we get an effective reduction of  $G$ , and this is impossible since  $G$  is minimal.

By using Theorem D.7 we get

$$F \cdot (l_n \oplus \vee_p^k) \xrightarrow{a\gamma} \circ \xleftarrow{a\beta} (l_m \oplus \vee_p^k) \cdot G$$

Now the desired equivalence

$$F \uparrow^{kp} \xleftrightarrow{a\delta} G \uparrow^p$$

follows from Lemma 7.21 applied for  $A = a\delta$ ,  $B = a\alpha$ ,  $C = a\gamma$  and  $D = a\beta$ . The conditions there hold true. Only condition (3) that lemma requires some attention. We check it in some details below. Recall that it is:

$$H \underset{u}{\xleftarrow{a\beta}} (l_m \oplus \vee_p^k) \cdot G \Rightarrow \exists H' : H = (l_m \oplus \vee_p^k) \cdot H' \ \& \ H' \underset{u}{\xleftarrow{a\beta}} G$$

If  $H = (\underline{y}, h)$ , the simulation shows that

$$(l_{m \oplus p} \oplus o(u)) h = (l_m \oplus \vee_p^k \oplus l_{o(\underline{x})}) g (l_{n \oplus p} \oplus i(u))$$

hence

$$(\top_m \oplus l_{kp} \oplus \top_{o(\underline{y})}) h = \vee_p^k g'$$

where  $g' = (\top_m \oplus l_p \oplus \top_{o(\underline{x})}) g (l_{n \oplus p} \oplus i(u))$ .

Now, take the pair

$$H' = (\underline{y}, h')$$

where

$$h' = [(l_m \oplus \top_{kp \oplus o(\underline{y})}) h \oplus g' \oplus (\top_{m \oplus kp} \oplus l_{o(\underline{y})}) h] \vee_{n \oplus p \oplus i(\underline{y})}^3$$

Then it is obvious that

$$(l_m \oplus \vee_p^k) H' = H$$

Moreover,

$$H' \underset{u}{\leftarrow} G$$

follows by

$$\begin{aligned} & (l_{m \oplus kp} \oplus o(u)) \cdot [(l_m \oplus \top_{kp \oplus o(\underline{y})}) h \oplus g' \oplus (\top_{m \oplus kp} \oplus l_{o(\underline{y})}) h] \cdot \vee_{n \oplus p \oplus i(\underline{y})}^3 \\ &= [(l_m \oplus \top_{kp \oplus o(\underline{y})}) h \oplus (\top_m \oplus l_p \oplus \top_{o(\underline{x})}) g (l_{n \oplus p} \oplus i(u)) \oplus (\top_{m \oplus kp} \oplus o(u)) h] \cdot \vee_{n \oplus p \oplus i(\underline{y})}^3 \\ &= [(l_m \oplus \top_{kp \oplus o(\underline{x})}) g (l_{n \oplus p} \oplus i(u)) \oplus (\top_m \oplus l_p \oplus \top_{o(\underline{x})}) g (l_{n \oplus p} \oplus i(u)) \\ &\quad \oplus (\top_{m \oplus p} \oplus l_{o(\underline{x})}) g (l_{n \oplus p} \oplus i(u))] \cdot \vee_{n \oplus p \oplus i(\underline{y})}^3 \\ &= g \cdot (l_{n \oplus p} \oplus i(u)) \end{aligned}$$

□

**Corollary 8.16** ( $\xleftrightarrow{a\delta} = \sim_{a\delta}$ )

The equivalence relation generated by simulation via  $a\delta$ -morphisms coincides with the equivalence relation generated by  $C_{a\delta}$ -var in the class of the equivalence relations satisfying  $\text{Enz}_{a\delta}$ , i.e. shortly

$$\xleftrightarrow{a\delta} = \sim_{a\delta}$$

**Proof:** It follows by Proposition 7.15 and Theorem 8.15.  $\square$

Finally, combining Theorem 8.15 and Corollary 7.19 we get the following theorem which shows that the  $a\delta$ -flow structure is preserved when one passes from the support theory of connections to the classes of similar pairs.

**Theorem 8.17** *If  $T$  is an  $a\delta$ -flow, then  $\mathbb{F}\ell_{a\delta}[X, T]$  is an  $a\delta$ -flow, too.*

### 8.3.2 Correctness Theorem

The above theorems (Theorem 8.17 and 8.13) show that the  $a\alpha$ -Flow-Calculus is correct with respect to the input behaviour, in the case of concrete deterministic flowgraphs, i.e. over  $\mathbb{P}\text{fn}$ .

## 8.4 Completeness of $a\delta$ -Flow-Calculus with respect to the input behaviour

In order to get the meaning of the  $a\delta$ -flownomials we combine Corollary 8.3.1 and Theorem 8.17 with the observation that the morphism  $\varphi^\#$  in Theorem 5.28 obtained in the particular case when  $Q = R_X$  and when  $\varphi_{\mathbb{P}\text{fn}}$  and  $\varphi_X$  are the natural embeddings of  $\mathbb{P}\text{fn}$  and  $X$  into  $R_X$  is the unfolding of flowgraphs. Hence:

**Theorem 8.18** *( $a\delta$ -flownomials = input behaviours of flowgraphs)*

*The algebras  $\mathbb{F}\ell_{EXP}[X, \mathbb{P}\text{fn}]/\sim_{a\delta}$ ,  $\text{INF}\ell[X, \mathbb{P}\text{fn}]/\overset{a\delta}{\longleftrightarrow}$  and  $R_X$  are isomorphic.  $\square$*

**Corollary 8.19** *The following conditions are equivalent for two flownomial expressions  $E$  and  $E'$  in  $\mathbb{F}\ell_{EXP}[X, \mathbb{P}\text{fn}]$ :*

1.  $E \sim_{a\delta} E'$
  2.  $\text{nf}(E) \overset{a\delta}{\longleftrightarrow} \text{nf}(E')$
  3. *The flowgraphs associated to  $E$  and  $E'$  unfold into the same tuple of trees.*
  4. *The computation processes denoted by  $E$  and  $E'$  have the same computation sequences.*
- $\square$

## 8.5 Universality of $a\delta$ -flownomials

**Theorem 8.20** *(universality of  $a\delta$ -flownomials)*

*Let  $T$  be an  $a\delta$ -flow.*

- (i) *The algebra  $\mathbb{F}\ell_{EXP}[X, T]/\sim_{a\delta}$  of  $a\delta$ -flownomials is an  $a\delta$ -flow and it is isomorphic to the algebra  $\mathbb{F}\ell[X, T]/\overset{a\delta}{\longleftrightarrow}$  of the classes of  $\overset{a\delta}{\longleftrightarrow}$ -equivalent flowgraphs.*



(ii) There exist two embeddings  $E_X^{a\delta}$  and  $E_T^{a\delta}$  of  $X$  and  $T$  into  $\mathbb{F}\ell_{a\delta}[X, T]$ , respectively, where  $E_X^{a\delta}$  is a function and  $E_T^{a\delta}$  is a morphism of  $a\delta$ -flows, such that for every  $a\delta$ -flow  $Q$  and every pair  $(\varphi_X, \varphi_T)$ , where  $\varphi_X : X \rightarrow Q$  is a function and  $\varphi_T : T \rightarrow Q$  is a morphism of  $a\delta$ -flows, there exists a unique morphism of  $a\delta$ -flows  $\varphi^\# : \mathbb{F}\ell_{a\delta}[X, T] \rightarrow Q$  such that  $E_X^{a\delta} \cdot \varphi^\# = \varphi_X$  and  $E_T^{a\delta} \cdot \varphi^\# = \varphi_T$ .  $\square$

$\mathbb{P}\text{fn}$  is the initial  $a\delta$ -flow in the category of  $a\delta$ -flows. By applying the above theorem in this particular case  $T = \mathbb{P}\text{fn}$  we get the following corollary.

**Corollary 8.21** (*free  $a\delta$ -flow*)

$\mathbb{F}\ell_{a\delta}[X, \mathbb{P}\text{fn}]$  is the  $a\delta$ -flow freely generated by  $X$ .  $\square$

## 8.6 The dual version: output behaviour ( $d\alpha$ -flow)

All the results given in this chapter holds in the dual case, i.e. replacing  $a\delta$  by  $d\alpha$ . In this dual form, the behaviour of a multiple-entries/multiple-exits variable may be specified by a tuple of multiple-entries/single-exit ones. After such a transformation for every output the resulting flowgraph may be unfolded into a (regular) tree, but now towards the inputs. The resulting tuple of regular tree gives the *output behaviour* of the flowgraph.

## 8.7 Short comments and references

The results of this chapter are from [Ste87a]. We have followed the presentation in Chapter D, sec. 1–3 of [Ste91].

In the particular case of flowgraphs connected by partial functions a stronger result is provided by the equational axiomatisation of regular trees obtained by Esik, see [Esi80]. Esik's idea was to replace the enzymatic axiom for functions by an weaker equational version. A problem with Esik's axiom is the fact that it is a difficult, global one and up to now there is no better axiomatisation than the original one given in 1980. See [BlEs93a] for more informations.

The dual case of dataflow networks is based on Broy's model of stream processing functions. See [Bro92a, Bro92b, BrS94].

# Chapter 9

## Nondeterministic one-way behaviour

In this short chapter we study the input behaviour of nondeterministic flowcharts. The main axiomatisation result is just a combination of the above theorem ( $a\delta$ -flow) and the axiomatisation of flowgraphs with arbitrary  $d\delta$ -constants. This simple extension is important since for single-input/single-output atoms, two flowgraphs have the same input behaviour iff they are bisimilar.

### 9.1 Axiomatising bisimilar flowgraphs

The words “deterministic” and “nondeterministic” should be used with some care in the present calculus. We have an abstract calculus and we are free to use any kind of theory for connections, providing the hypotheses we use hold true. For example, the results in the previous chapter (except for the meaning, which was given in the particular case  $T = \mathbb{P}\text{fn}$ ) still work if the connecting theory is  $\mathbb{R}\text{el}$ .

To clarify the matters, we use the same convention as in Chapter 6:

*The words “deterministic” and “nondeterministic” refer to the syntactical aspects of the calculus.*

Hence, what we have to do here is to add nondeterminism to the syntactic part, hence to use a  $d\delta$ -ssms with feedback.

Why this is a separate chapter? Because the meaning of the  $\overset{a\delta}{\longleftrightarrow}$ -equivalence is very important. Namely, the following result has been proved in [BeS93, BeS94a].

**Theorem 9.1** (for flowgraphs over  $\mathbb{R}\text{el}$ :  $\overset{a\delta}{\longleftrightarrow}$ -equivalence = bisimulation)

*When the support theory is  $\mathbb{R}\text{el}$  and we are using only single-entry/single-exit variables the  $\overset{a\delta}{\longleftrightarrow}$ -equivalence coincides with bisimulation.  $\square$*

Now the main result of this chapter is a corollary of Theorem 6.5 and of the result of the previous chapter.

**Theorem 9.2** *If  $T$  is an  $d\delta$ -ssmc with feedback, then*

- (Correctness)  $\mathbb{F}\ell_{a\alpha}[X, T]$  is an  $d\delta$ -ssms with feedback.
- (Completeness) *The rules of  $a\delta$ -flow and  $d\delta$ -ssmc with feedback are complete for flowgraphs with single-entry/single-exit variables modulo bisimulation.  $\square$*

## 9.2 Short comments and references

Bisimulation is a standard equivalence used in the algebraic studies on concurrent processes. It was introduced in [Park80] in connection with Milner's work on concurrency [Mil80, Mil89]. See also [BeK84, BaW90, BenT89, BIET93].

The main result of this chapter is based on [BeS93, BeS94a] where it is shown that bisimulation is the equivalence relation generated by simulation via functions in a nondeterministic setting.

[It is a bit strange to see such a late integration of the process algebra and the algebra of flowchart schemes, both having their roots in Kleene regular algebra.]

# Chapter 10

## Deterministic input-output behaviour ( $b\delta$ -flow)

This chapter is devoted to the study of the input-output step-by-step behaviour of deterministic flowgraphs.

In order to get an axiomatisation for this behaviour of flowgraphs the  $b\delta$ -flow is used. Such a structure is obtained adding the strong axioms and the enzymatic rule for partial functions to the graph-isomorphism axioms.

The main result of this chapter shows that this structure give a correct and complete axiomatisation for the input-output behaviour of deterministic flowgraphs.

### 10.1 Characterization theorem for $\longleftrightarrow^{b\delta}$ ; ( $\longleftrightarrow^{b\delta}$ -minimization)

In this  $b\delta$  case we use simulation via partially defined functions and we look for a theorem similar to Theorem 8.7 proved in the  $a\delta$  case. Actually we shall prove that

$$\longleftrightarrow^{b\delta} = \xrightarrow{b\alpha} \circ \xrightarrow{a\gamma} \circ \xleftarrow{a\beta} \circ \xrightarrow{a\beta} \circ \xleftarrow{a\gamma} \circ \xleftarrow{b\alpha} .$$

This means that two normal form flownomial expressions are  $\longleftrightarrow^{b\delta}$ -equivalent iff by

- (1) deletion of noncoaccessible vertices (i.e. vertices for which no path reaching an output does exist),
- (2) reduction, and
- (3) deletion of nonaccessible vertices

the associated flowgraphs may be brought to the same form.

We start with the proof of some commutation lemmas for the elementary simulations that appear. Since in the characterization theorem we want to prove for  $\longleftrightarrow^{b\delta}$  the simulations  $\xrightarrow{a\beta}$ ,  $\xrightarrow{a\gamma}$  and their converses occur in the same order as in Theorem 8.7 the commutation lemmas used in the  $a\delta$  case are still useful here. So that it remains to prove

- the commutations of the simulations  $\xrightarrow{b\alpha}$  and  $\xleftarrow{b\alpha}$  with the other ones.

Table 10.1: Is  $x \circ y \subseteq y \circ x$ ? (case  $b\delta$ )

$x$	$\xrightarrow{b\alpha}$	$\xrightarrow{a\gamma}$	$\xleftarrow{a\beta}$	$\xrightarrow{a\beta}$	$\xleftarrow{a\gamma}$	$\xleftarrow{b\alpha}$
$\xrightarrow{b\alpha}$	Obvious					
$\xrightarrow{a\gamma}$	10.1	Obvious				
$\xleftarrow{a\beta}$	10.3	8.4	Obvious			
$\xrightarrow{a\beta}$	10.2	8.1	8.3	Obvious		
$\xleftarrow{a\gamma}$	10.5	8.6	8.2	8.5	Obvious	
$\xleftarrow{b\alpha}$	8.3 <sup>o</sup>	10.5 <sup>op</sup>	10.2 <sup>op</sup>	10.3 <sup>op</sup>	10.1 <sup>op</sup>	Obvious

The commutation  $\xleftarrow{b\alpha} \circ \xrightarrow{b\alpha} \subseteq \xrightarrow{b\alpha} \circ \xleftarrow{b\alpha}$  follows from Lemma 8.3 by duality, and the other ones in the bottom line of Table 8.1 are converses of some ones occurring in the left hand side column of that table. So that

- four cases remain to be proved: the commutations of the simulations  $\xrightarrow{a\gamma}$ ,  $\xrightarrow{a\beta}$ ,  $\xleftarrow{a\beta}$  and  $\xleftarrow{a\gamma}$  with  $\xrightarrow{b\alpha}$ .

(See Table 10.1.)

The general framework we shall use here is given by a support theory  $T$  which is a  $b\delta$ -ssmc equipped with a feedback operation. Sometimes we shall use the following hypothesis:

- (IP) if  $f \cdot (y_1 \oplus y_2) = g \oplus \top_q$  then  $f = f \cdot (l_n \oplus \perp^p \cdot \top_p)$ ,  
 where  $f \in T(m, n \oplus p)$  and both  $y_1$  and  $y_2 (: p \rightarrow q)$  are  $a\gamma$ -morphisms.

Actually, this hypothesis IP says that if after some identifications of the outputs of  $f$  certain outputs become dummy, then these outputs were dummy before the identification, too.

**Lemma 10.1**  $\xrightarrow{a\gamma} \circ \xrightarrow{b\alpha} \subseteq \xrightarrow{b\alpha} \circ \xrightarrow{a\gamma}$ , when  $T$  is a strong  $b\delta$ -ssmc that satisfies condition IP.

**Proof:** Let

$$F' \xrightarrow{a\gamma}_{u'} F \xrightarrow{b\alpha}_{u''} F''$$

By using isomorphic representations we may suppose that

$$F' = (a \oplus b, f'), F = (c \oplus d, f), F'' = (c, f'') \text{ and } u' = u_1 \oplus u_2 \text{ (where } u_1 : a \rightarrow c), u'' = l_c \oplus \perp^d.$$

The given simulations show that:

- (1)  $f' (l_n \oplus i(u_1 \oplus u_2)) = (l_n \oplus o(u_1 \oplus u_2)) f$  and
- (2)  $f (l_n \oplus i(l_c \oplus \perp^d)) = (l_m \oplus o(l_c \oplus \perp^d)) f''$ .

Take the pair

$$\overline{F} = (a, \overline{f}) \text{ where } \overline{f} = (l_m \oplus o(l_a \oplus \top_b)) f' (l_n \oplus i(l_a \oplus \perp^b))$$

We show that

$$F' \xrightarrow{b\alpha}_{l_a \oplus \perp^b} \overline{F} \xrightarrow{a\gamma}_{u_1} F''$$

For the right simulation is easy:

$$\begin{aligned}
\bar{f} \cdot (l_n \oplus i(u_1)) &= (l_m \oplus o(l_a \oplus \top_b)) f' (l_n \oplus i(u_1 \oplus \perp^b)) \\
&= (l_n \oplus o(l_a \oplus \top_b)) f' (l_n \oplus i(u_1 \oplus u_2 \perp^d)) \\
&= (l_m \oplus o(u_1 \oplus \top_b \cdot u_2)) f (l_n \oplus i(l_c \oplus \perp^d)) && \text{by (1)} \\
&= (l_m \oplus o(u_1 \oplus \top_d \cdot \perp^d)) \cdot f'' && \text{by (2)} \\
&= (l_m \oplus o(u_1)) \cdot f''
\end{aligned}$$

For the left one, first note that (1) and (2) implies

$$f' \cdot (l_n \oplus i(u_1 \oplus \perp^b)) = (l_m \oplus o(u_1 \oplus \perp^b)) \cdot f''$$

hence

$$\begin{aligned}
(\top_m \oplus o(\top_a \oplus l_b)) \cdot f' \cdot (l_n \oplus i(u_1 \oplus \perp^b)) &= (\top_m \oplus o(\top_c \oplus \top_b)) \cdot f'' \\
&= \top_{n \oplus i(c)} && \text{by } (C_{a\beta}\text{-mor})
\end{aligned}$$

Applying hypothesis IP for surjection  $l_n \oplus i(u_1)$  one gets

$$\begin{aligned}
(3) \quad (\top_m \oplus o(\top_a \oplus l_b)) \cdot f' \cdot (l_n \oplus i(l_a \oplus \perp^b)) & \\
= [(\top_m \oplus o(\top_a \oplus l_b)) f' (l_n \oplus i(l_a \oplus \perp^b))] \cdot \perp^{n \oplus i(a)} \cdot \top_{n \oplus i(a)} & \\
= \perp^b \cdot \top_{n \oplus i(a)} && \text{by } (C_{b\alpha}\text{-mor})
\end{aligned}$$

Finally,

$$\begin{aligned}
&(l_m \oplus o(l_a \oplus \perp^b)) \cdot \bar{f} \\
&= (l_m \oplus o(l_a \oplus \perp^b \cdot \top_b)) f' (l_n \oplus i(l_a \oplus \perp^b)) \\
&= [ (l_m \oplus o(l_a \oplus \top_b)) f' (l_n \oplus i(l_a \oplus \perp^b)) \\
&\quad \oplus (\top_m \oplus o(\top_a \oplus \underline{\perp^b \cdot \top_b} \cdot l_b)) f' (l_n \oplus i(l_a \oplus \perp^b)) ] \cdot \vee_{n \oplus i(a)} \quad \text{by } (C_{a\gamma}\text{-mor})
\end{aligned}$$

Using (3) one may eliminate the underlined term and gets

$$(l_m \oplus o(l_a \oplus \perp^b)) \cdot \bar{f} = f' \cdot (l_n \oplus i(l_a \oplus \perp^b)) \quad \text{by } (C_{a\gamma}\text{-mar})$$

□

**Lemma 10.2**  $\xrightarrow{a\beta} \circ \xrightarrow{b\alpha} \subseteq \xrightarrow{b\alpha} \circ \xrightarrow{a\beta}$ , when  $T$  is a  $b\beta$ -ssmc.

**Proof:** Let

$$F' \xrightarrow{a\beta}_{u'} F \xrightarrow{b\alpha}_{u''} F''$$

Using isomorphic representations we may suppose that

$$\begin{aligned}
F' &= (a \oplus b, f'), \quad F = (a \oplus b \oplus c \oplus d, f), \quad F'' = (b \oplus c, f'') \quad \text{and} \\
u' &= l_{a \oplus b} \oplus \top_{c \oplus d}, \quad u'' = \perp^a \oplus l_{b \oplus c} \oplus \perp^d.
\end{aligned}$$

The simulations show that:

- (1)  $f' \cdot (l_n \oplus i(l_{a \oplus b} \oplus \top_{c \oplus d})) = (l_m \oplus o(l_{a \oplus b} \oplus \top_{c \oplus d})) \cdot f$  and
- (2)  $f \cdot (l_n \oplus i(\perp^a \oplus l_{b \oplus c} \oplus \perp^d)) = (l_m \oplus o(\perp^a \oplus l_{b \oplus c} \oplus \perp^d)) \cdot f''.$

Take

$$\overline{F} = (b, \overline{f}) \quad \text{where} \quad \overline{f} = (l_m \oplus o(\top_a \oplus l_b \oplus \top_{c \oplus d})) f (l_n \oplus i(\perp^a \oplus l_b \oplus \perp^{c \oplus d}))$$

We show that

$$F' \xrightarrow{b\alpha} \perp^a \oplus l_b \overline{F} \xrightarrow{a\beta} l_b \oplus \top_c F''$$

Indeed, for the left simulation we may compute

$$\begin{aligned} & (l_m \oplus o(\perp^a \oplus l_b)) \cdot \overline{f} \\ &= (l_m \oplus o(\perp^a \cdot \top_a \oplus l_b \oplus \top_{c \oplus d})) f (l_n \oplus i(\perp^a \oplus l_b \oplus \perp^{c \oplus d})) \\ &= (l_m \oplus o(\perp^a \cdot \top_a \cdot \perp^a \oplus l_b \oplus \top_c \oplus \top_d \cdot \perp^d)) f'' (l_n \oplus i(l_b \oplus \perp^c)) \quad \text{by (2)} \\ &= (l_m \oplus o(l_{a \oplus b} \oplus \top_{c \oplus d})) f (l_n \oplus i(\perp^a \oplus l_b \oplus \perp^{c \oplus d})) \quad \text{by (2)} \\ &= f' (l_n \oplus i(\perp^a \oplus l_b \oplus \top_{c \oplus d} \cdot \perp^{c \oplus d})) \quad \text{by (1)} \\ &= f' \cdot (l_n \oplus i(\perp^a \oplus l_b)) \end{aligned}$$

In a similar way one may check that the condition for the right simulation holds.  $\square$

**Lemma 10.3**  $\xleftarrow{a\beta} \circ \xrightarrow{b\alpha} \subseteq \xrightarrow{b\alpha} \circ \xleftarrow{a\beta}$ , when  $T$  is an  $a\delta$ -strong  $b\delta$ -ssmc.

**Proof:** Let

$$F' \xleftarrow{u'} \xleftarrow{a\beta} F \xrightarrow{u''} \xrightarrow{b\alpha} F''$$

Using isomorphic representations we may suppose that

$$\begin{aligned} F' &= (a \oplus b \oplus c, f'), \quad F = (a \oplus b, f), \quad F'' = (a, f'') \quad \text{and} \\ u' &= l_{a \oplus b} \oplus \top_c, \quad u'' = l_a \oplus \perp^b. \end{aligned}$$

The simulations show that:

$$\begin{aligned} (1) \quad & f \cdot (l_n \oplus i(l_{a \oplus b} \oplus \top_c)) = (l_m \oplus o(l_{a \oplus b} \oplus \top_c)) \cdot f' \quad \text{and} \\ (2) \quad & f \cdot (l_n \oplus i(l_a \oplus \perp^b)) = (l_m \oplus o(l_a \oplus \perp^b)) \cdot f''. \end{aligned}$$

Take

$$\overline{F} = (a \oplus c, \overline{f}) \quad \text{where} \quad \overline{f} = (l_m \oplus o(l_a \oplus \top_b \oplus l_c)) f' (l_n \oplus i(l_a \oplus \perp^b \oplus l_c))$$

We show that

$$F' \xrightarrow{b\alpha} l_a \oplus \perp^b \oplus l_c \overline{F} \xleftarrow{a\beta} l_a \oplus \top_c F''$$

For the right simulation is easy,

$$\begin{aligned} (l_m \oplus o(l_a \oplus \top_c)) \cdot \overline{f} &= (l_m \oplus o(l_a \oplus \top_{b \oplus c})) f' (l_n \oplus i(l_a \oplus \perp^b \oplus l_c)) \\ &= (l_m \oplus o(l_a \oplus \top_b)) f (l_n \oplus i(l_a \oplus \perp^b \oplus \top_c)) \quad \text{by (1)} \\ &= (l_m \oplus o(l_a \oplus \top_b \cdot \perp^b)) f'' (l_n \oplus i(l_a \oplus \top_c)) \quad \text{by (2)} \\ &= f'' \cdot (l_n \oplus o(l_a \oplus \top_c)) \end{aligned}$$

For the left one, as above one may show that

$$\begin{aligned}
& (\top_m \oplus o(\top_a \oplus \perp_b \oplus \top_c)) \cdot f' \cdot (l_n \oplus i(l_a \oplus \perp^b \oplus l_c)) \\
&= (\top_m \oplus o(\top_a \oplus \perp^b)) f'' (l_n \oplus i(l_a \oplus \top_c)) \\
&= \perp^b \cdot \top_{n \oplus i(a \oplus c)} \qquad \text{by } (C_{a\beta}\text{-mor})
\end{aligned}$$

and using the algebraic theory rules one gets

$$\begin{aligned}
f' \cdot (l_n \oplus i(l_a \oplus \perp^b \oplus l_c)) &= (l_m \oplus o(l_a \oplus \perp^b \cdot \top_b \oplus l_c)) f' (l_n \oplus i(l_a \oplus \perp^b \oplus l_c)) \\
&= (l_m \oplus o(l_a \oplus \perp^b \oplus l_c)) \cdot \bar{f} \quad \square
\end{aligned}$$

**Example 10.4** In general the inclusion  $\xleftarrow{a\gamma} \circ \xrightarrow{b\alpha} \subseteq \xrightarrow{b\alpha} \circ \xleftarrow{a\gamma}$ , does not hold.  
For example, if  $x : 1 \rightarrow 1$  and  $F, F', F'' : 0 \rightarrow 0$  are given by the pairs

$$F' = (x, l_1), \quad F = (x \oplus x, \vee_1 \oplus \top_1), \quad F'' = (x, \perp^1 \cdot \top_1)$$

then

$$F' \xleftarrow{a\gamma} F \xrightarrow{b\alpha} F'' \quad \text{but} \quad (F', F'') \notin \xrightarrow{b\alpha} \circ \xleftarrow{a\gamma}$$

□

**Lemma 10.5**  $\xleftarrow{a\gamma} \circ \xrightarrow{b\alpha} \subseteq \xrightarrow{b\alpha} \circ \xleftarrow{a\gamma} \circ \xleftarrow{b\alpha}$ , when  $T$  is a strong  $b\delta$ -ssmc which obeys condition IP.

**Proof:** Let

$$F' \xleftarrow{u'} \xleftarrow{a\gamma} F \xrightarrow{b\alpha} \xrightarrow{u''} F''$$

Using isomorphisms we may order the variables in  $F$  as  $a \oplus b$  such that  $u'' = l_a \oplus \perp^b$ . Next, we order the variables in  $F'$  as  $c \oplus e \oplus d$ , where  $\{|c|+1, \dots, |c|+|e|\}$  is the intersection of the images via  $u'$  of the sets  $\{1, \dots, |a|\}$  and  $\{|a|+1, \dots, |a|+|b|\}$ . Finally, we order again the variables in  $a$  and  $b$  corresponding to  $F$  as  $a' \oplus a''$  and  $b'' \oplus b'$  such that the preimage via  $u'^{-1}$  of  $\{|c|+1, \dots, |c|+|e|\}$  be  $\{|a'|+1, \dots, |a'|+|a'' \oplus b''|\}$ . Consequently we may suppose the pairs are of the following type

$$\begin{aligned}
F' &= (c \oplus e \oplus d, f'), \quad F = (a' \oplus a'' \oplus b'' \oplus b', f), \quad F'' = (a' \oplus a'', f'') \quad \text{and} \\
u'' &= l_{a' \oplus a''} \oplus \perp^{b'' \oplus b'}, \quad u' = u_1 \oplus (u_2 \oplus u_3) \cdot \vee_e \oplus u_4, \\
&\text{where } u_1 : a' \rightarrow c, \quad u_2 : a'' \rightarrow e, \quad u_3 : b'' \rightarrow e \text{ and } u_4 : b' \rightarrow d \text{ are } a\gamma\text{-morphisms.}
\end{aligned}$$

The simulations show that:

- (1)  $f \cdot (l_n \oplus i(u_1 \oplus (u_2 \oplus u_3) \vee_e \oplus u_4)) = (l_m \oplus o(u_1 \oplus (u_2 \oplus u_3) \vee_e \oplus u_4)) \cdot f'$  and
- (2)  $f \cdot (l_n \oplus i(l_{a' \oplus a''} \oplus \perp^{b'' \oplus b'})) = (l_m \oplus o(l_{a' \oplus a''} \oplus \perp^{b'' \oplus b'})) \cdot f''.$

Take the pairs

$$\bar{F} = (c, \bar{f}) \quad \text{where} \quad \bar{f} = (l_m \oplus o(l_c \oplus \top_{e \oplus d})) f' (l_n \oplus i(l_c \oplus \perp^{e \oplus d}))$$

and

$$\tilde{F} = (a', \tilde{f}) \quad \text{where} \quad \tilde{f} = (l_m \oplus o(l_{a'} \oplus \top_{a''})) f'' (l_n \oplus i(l_{a'} \oplus \perp^{a''}))$$

We show that

$$F' \xrightarrow{b\alpha} l_{c \oplus \perp^{e \oplus d}} \bar{F} \xleftarrow{u_1} \xleftarrow{a\gamma} \tilde{F} \xleftarrow{b\alpha} l_{a' \oplus \perp^{a''}} F''$$

One may check that the condition for the middle simulation as follows



$$\begin{aligned}
& (l_m \oplus o(u_1)) \cdot \bar{f} \\
&= (l_m \oplus o(u_1 \oplus \top_{e \oplus d})) f' (l_n \oplus i(l_c \oplus \perp^{e \oplus d})) \\
&= (l_m \oplus o(l_{a'} \oplus \top_{a'' \oplus b'' \oplus b'})) (l_m \oplus o(u_1 \oplus (u_2 \oplus u_3) \vee_e \oplus u_4)) \\
&\quad \cdot f' (l_n \oplus i(l_c \oplus \perp^{e \oplus d})) \\
&= (l_m \oplus o(l_{a'} \oplus \top_{a'' \oplus b'' \oplus b'})) f (l_n \oplus i(u_1 \oplus \perp^{a'' \oplus b'' \oplus b'})) && \text{by (1)} \\
&= (l_m \oplus o(l_{a'} \oplus \top_{a''} \oplus \top_{b'' \oplus b'} \cdot \perp^{b'' \oplus b'})) f'' (l_n \oplus i(u_1 \oplus \perp^{a''})) && \text{by (2)} \\
&= \tilde{f} \cdot (l_n \oplus i(u_1))
\end{aligned}$$

For the left simulation suppose that  $v_1 : c \rightarrow a'$ ,  $v_3 : e \rightarrow b''$  and  $v_4 : d \rightarrow b'$  are left inverses of  $u_1$ ,  $u_3$  and  $u_4$ , respectively. Hence

$$\begin{aligned}
& f' \cdot (l_n \oplus i(l_c \oplus \perp^{e \oplus d})) \\
&= (l_m \oplus o(v_1 u_1 \oplus (\top_{a''} u_2 \oplus v_3 u_3) \vee_e \oplus v_4 u_4)) f' (l_n \oplus i(l_c \oplus \perp^{e \oplus d})) \\
&= (l_m \oplus o(v_1 \oplus \top_{a''} \oplus v_3 \oplus v_4)) f (l_n \oplus i(u_1 \oplus \perp^{a'' \oplus b'' \oplus b'})) && \text{by (1)} \\
&= (l_m \oplus o(v_1 \oplus \top_{a''} \oplus \perp^{e \oplus d})) f'' (l_n \oplus i(u_1 \oplus \perp^{a''})) && \text{by (2)}
\end{aligned}$$

If we compose on left with  $l_m \oplus o(l_c \oplus \perp^{e \oplus d} \cdot \top_{e \oplus d})$  then the last term remains unchanged. Hence,

$$\begin{aligned}
(*) \quad f' \cdot (l_n \oplus i(l_c \oplus \perp^{e \oplus d})) &= (l_m \oplus o(l_c \oplus \perp^{e \oplus d} \cdot \top_{e \oplus d})) f' (l_n \oplus i(l_c \oplus \perp^{e \oplus d})) \\
&= (l_m \oplus o(l_c \oplus \perp^{e \oplus d})) \bar{f}
\end{aligned}$$

Finally, for the right simulation, let us first note that

$$\begin{aligned}
& (\top_m \oplus o(\top_{a'} \oplus l_{a''})) \cdot f'' \cdot (l_n \oplus i(u_1 \oplus \perp^{a''})) \\
&= (\top_m \oplus o(\top_{a'} \oplus l_{a''} \oplus \top_{b'' \oplus b'} \cdot \perp^{b'' \oplus b'})) f'' (l_n \oplus i(u_1 \oplus \perp^{a''})) \\
&= (\top_m \oplus o(\top_{a'} \oplus l_{a''} \oplus \top_{b'' \oplus b'})) f (l_n \oplus i(u_1 \oplus \perp^{a'' \oplus b'' \oplus b'})) && \text{by (2)} \\
&= (\top_m \oplus o(\top_{a'} \oplus l_{a''} \oplus \top_{b'' \oplus b'})) f (l_n \oplus i(u_1 \oplus [(u_2 \oplus u_3) \vee_e \oplus u_4] \perp^{e \oplus d})) \\
&= (\top_m \oplus o(\top_{a'} u_1 \oplus (u_2 \oplus \top_{b''} u_3) \vee_e \oplus \top_{b'} u_4)) f' (l_n \oplus i(l_c \oplus \perp^{e \oplus d})) && \text{by (1)} \\
&= (\top_m \oplus o(\top_c \oplus u_2 \oplus \top_d)) (l_n \oplus o(l_c \oplus \perp^{e \oplus d} \cdot \top_{e \oplus d})) f' (l_n \oplus i(l_c \oplus \perp^{e \oplus d})) && \text{by (*)} \\
&= (\top_m \oplus o(\top_c \oplus \perp^{a''} \cdot \top_e \oplus \top_d)) f' (l_n \oplus i(l_c \oplus \perp^{e \oplus d})) \\
&= \perp^{a''} \cdot \top_{n \oplus i(c)} && (C_{a\beta}\text{-mor})
\end{aligned}$$

Applying hypothesis IP for the  $a\gamma$ -morphism  $l_n \oplus i(u_1)$  we get

$$\begin{aligned}
(**) \quad (\top_m \oplus o(\top_{a'} \oplus l_{a''})) \cdot f'' \cdot (l_n \oplus i(l_{a'} \oplus \perp^{a''})) \\
&= (\top_m \oplus o(\top_{a'} \oplus l_{a''})) f'' (\perp^n \cdot \top_n \oplus i(\perp^{a'} \cdot \top_{a'} \oplus \perp^{a''})) \\
&= \perp^{a''} \cdot \top_{n \oplus i(a')} && \text{by } (C_{b\alpha}\text{-mor})
\end{aligned}$$

Now the requested identity follows by

$$\begin{aligned}
& (l_m \oplus o(l_{a'} \oplus \perp^{a''})) \cdot \tilde{f} \\
&= (l_m \oplus o(l_{a'} \oplus \perp^{a''} \cdot \top_{a''})) f'' (l_n \oplus i(l_{a'} \oplus \perp^{a''})) \\
&= [(l_m \oplus o(l_{a'} \oplus \top_{a''})) f'' (l_n \oplus i(l_{a'} \oplus \perp^{a''})) \\
&\quad \oplus (\top_m \oplus o(\top_{a'} \oplus \perp^{a''} \cdot \top_{a''} \cdot l_{a''})) f'' (l_n \oplus i(l_{a'} \oplus \perp^{a''}))] \cdot \vee_{a \oplus i(a')} && \text{by } (C_{a\gamma}\text{-mor}) \\
&= [(l_m \oplus o(l_{a'} \oplus \top_{a''})) f'' (l_n \oplus i(l_{a'} \oplus \perp^{a''})) \oplus \perp^{a''} \cdot \top_{n \oplus i(a')}] \cdot \vee_{a \oplus i(a')} && \text{by } (C_{a\beta}\text{-mor}) \\
&= [(l_m \oplus o(l_{a'} \oplus \top_{a''})) f'' (l_n \oplus i(l_{a'} \oplus \perp^{a''})) \\
&\quad \oplus (\top_m \oplus o(\top_{a'} \oplus l_{a''})) f'' (l_n \oplus i(l_{a'} \oplus \perp^{a''}))] \cdot \vee_{n \oplus i(a')} && \text{by (**)} \\
&= f'' \cdot (l_n \oplus i(l_{a'} \oplus \perp^{a''})) && \text{by } (C_{a\gamma}\text{-mor})
\end{aligned}$$

□

Besides these commuting lemmas we need the following decomposition result showing that  $\xrightarrow{b\delta}$  and  $\xrightarrow{a\beta} \cup \xrightarrow{a\gamma} \cup \xrightarrow{b\alpha}$  generate the same equivalence relation.

**Lemma 10.6**  $\xrightarrow{b\delta} \subseteq \xrightarrow{b\alpha} \circ \xrightarrow{a\delta}$ , when  $T$  is an  $a\delta$ -strong  $b\delta$ -ssmc and obeys condition IP.

**Proof:** Suppose

$$F' \xrightarrow{b\delta}_u F''$$

Using isomorphisms we may suppose that

$$\begin{aligned} F' &= (a \oplus b, f'), \quad F'' = (c \oplus d, f'') \text{ and} \\ u &= (l_a \oplus \perp^b) v (l_c \oplus \top_d) \text{ for an } a\gamma\text{-morphism } v : a \rightarrow c. \end{aligned}$$

This means

$$(1) \quad f'(l_n \oplus i((l_a \oplus \perp^b) v (l_c \oplus \top_d))) = (l_m \oplus o((l_a \oplus \perp^b) v (l_c \oplus \top_d)))f''.$$

Take the pair

$$\overline{F} = (a, \overline{f}) \quad \text{where} \quad \overline{f} = (l_m \oplus o(l_a \oplus \top_b)) \cdot f' \cdot (l_n \oplus i(l_a \oplus \perp^b))$$

We show that

$$F' \xrightarrow{b\alpha}_{l_a \oplus \perp^b} \overline{F} \xrightarrow{a\delta}_{v(l_c \oplus \top_d)} F''$$

For the right simulation it is easy to see that

$$\begin{aligned} \overline{f} \cdot (l_n \oplus i(v(l_c \oplus \top_d))) &= (l_m \oplus o(l_a \oplus \top_b)) f' [l_n \oplus i((l_a \oplus \perp^b) v (l_c \oplus \top_d))] \\ &= [l_m \oplus o((l_a \oplus \top_b \perp^b) v (l_c \oplus \top_d))] f'' && \text{by (1)} \\ &= (l_m \oplus o(v(l_c \oplus \top_d))) \cdot f'' \end{aligned}$$

For the left simulation, let us first note that

$$\begin{aligned} &[(\top_m \oplus o(\top_a \oplus l_b)) \cdot f' \cdot (l_n \oplus i(l_a \oplus \perp^b))] \cdot (l_n \oplus i(v)) \\ &= (\top_m \oplus o(\top_a \oplus l_b)) f' [l_n \oplus i((l_a \oplus \perp^b) v (l_c \oplus \top_d \cdot \perp^d))] \\ &= [\top_m \oplus o((\top_a \oplus \perp^b) v (l_c \oplus \top_d))] f'' (l_n \oplus i(l_c \oplus \perp^d)) && \text{by (1)} \\ &= \perp^b \cdot \top_{m \oplus i(c \oplus d)} \cdot f'' (l_n \oplus i(l_c \oplus \perp^d)) \\ &= \perp^b \cdot \top_{n \oplus i(c)} && \text{by } (C_{a\beta}\text{-mor}) \end{aligned}$$

Applying hypothesis IP for surjection  $l_n \oplus i(v)$  we get

$$\begin{aligned} (*) \quad &(\top_m \oplus o(\top_a \oplus l_b)) \cdot f' \cdot (l_n \oplus i(l_a \oplus \perp^b)) \\ &= [(\top_m \oplus o((\top_a \oplus l_b)) f' (l_n \oplus i(l_a \oplus \perp^b)))] \cdot \perp^{n \oplus i(a)} \cdot \top_{n \oplus i(a)} \\ &= \perp^b \cdot \top_{n \oplus i(a)} && \text{by } (C_{b\alpha}\text{-mor}) \end{aligned}$$

Hence

$$\begin{aligned}
& (l_m \oplus o(l_a \oplus \perp^b)) \cdot \bar{f} \\
&= (l_m \oplus o(l_a \oplus \perp^b \top_b)) f' (l_n \oplus i(l_a \oplus \perp^b)) \\
&= [(l_m \oplus o(l_a \oplus \top_b)) f' (l_n \oplus i(l_a \oplus \perp^b)) \\
&\quad \oplus (\top_m \oplus o(\top_a \oplus \perp^b \top_b)) f' (l_n \oplus i(l_a \oplus \perp^b))] \cdot \vee_{n \oplus i(a)} && \text{by } (C_{a\gamma}\text{-mor}) \\
&= [(l_m \oplus o(l_a \oplus \top_b)) f' (l_n \oplus i(l_a \oplus \perp^b)) \oplus \perp^b \cdot \top_{n \oplus i(a)}] \cdot \vee_{n \oplus i(a)} && \text{by } (C_{a\beta}\text{-mor}) \\
&= [(l_m \oplus o(l_a \oplus \top_b)) f' (l_n \oplus i(l_a \oplus \perp^b)) \\
&\quad \oplus (\top_m \oplus o(\top_a \oplus l_b)) f' (l_n \oplus i(l_a \oplus \perp^b))] \cdot \vee_{n \oplus i(a)} && \text{by } (*) \\
&= f' \cdot (l_n \oplus i(l_a \oplus \perp^b)) && \text{by } (C_{a\gamma}\text{-mor})
\end{aligned}$$

□

Using these lemmas we may prove the following

**Theorem 10.7** (characterization theorem for  $\overset{b\delta}{\leftarrow\rightleftarrows}$ )

If  $T$  is a strong  $b\delta$ -ssmc which obeys IP, then in  $\text{NF}\ell[X, T]$  the following decomposition holds:

$$\overset{b\delta}{\leftarrow\rightleftarrows} = \xrightarrow{b\alpha} \circ \xrightarrow{a\gamma} \circ \xleftarrow{a\beta} \circ \xrightarrow{a\beta} \circ \xleftarrow{a\gamma} \circ \xleftarrow{b\alpha} .$$

**Proof:** Lemmas 8.1 and 10.6 show that both relations  $\overset{b\delta}{\leftarrow\rightleftarrows}$  and  $\xrightarrow{b\alpha} \cup \xrightarrow{a\gamma} \cup \xrightarrow{a\beta}$  generate the same equivalence relation. Let  $\rho = \xrightarrow{b\alpha} \circ \xrightarrow{a\gamma} \circ \xleftarrow{a\beta} \circ \xrightarrow{a\beta} \circ \xleftarrow{a\gamma} \circ \xleftarrow{b\alpha}$ . It is clear that

$$F' \overset{b\delta}{\leftarrow\rightleftarrows} F'' \quad \text{iff} \quad \exists n \geq 1 \text{ such that } F' \rho^n F''$$

hence all we have to show is  $\rho^n \subseteq \rho$ .

From the commuting relations presented in Table 10.1 it follows that

$$\rho \circ \xleftarrow{a\beta}, \quad \rho \circ \xrightarrow{a\beta}, \quad \rho \circ \xleftarrow{a\gamma} \quad \text{and} \quad \rho \circ \xleftarrow{b\alpha} \quad \text{are included in } \rho$$

In the remaining cases it is necessary to use the commutation given by Lemma 10.5 that provides a commutation, but it adds an auxiliary term. Let us see what happens.

In one case is easy,

$$\begin{aligned}
\rho \circ \xrightarrow{b\alpha} &= (\xrightarrow{b\alpha} \circ \xrightarrow{a\gamma} \circ \xleftarrow{a\beta} \circ \xrightarrow{a\beta} \circ \xleftarrow{a\gamma} \circ \xleftarrow{b\alpha}) \circ \xrightarrow{b\alpha} \\
&\subseteq \xrightarrow{b\alpha} \circ \xrightarrow{a\gamma} \circ \xleftarrow{a\beta} \circ \xrightarrow{a\beta} \circ (\xleftarrow{a\gamma} \circ \xrightarrow{b\alpha}) \circ \xleftarrow{b\alpha} && \text{by } 8.3^o \\
&\subseteq \xrightarrow{b\alpha} \circ \xrightarrow{a\gamma} \circ \xleftarrow{a\beta} \circ \xrightarrow{a\beta} \circ (\xrightarrow{b\alpha} \circ \xleftarrow{a\gamma} \circ \xleftarrow{b\alpha}) \circ \xleftarrow{b\alpha} && \text{by } 10.5 \\
&\subseteq \rho && \text{by } 10.1\text{--}10.3
\end{aligned}$$

For the inclusion  $\rho \circ \xrightarrow{a\gamma} \subseteq \rho$ , suppose that  $(F', F'') \in \rho \circ \xrightarrow{a\gamma}_u$ . It follows that for a surjection  $u'$

$$\begin{aligned}
(F', F'') &\in (\xrightarrow{b\alpha} \circ \xrightarrow{a\gamma} \circ \xleftarrow{a\beta} \circ \xrightarrow{a\beta} \circ u' \xleftarrow{a\gamma} \circ \xleftarrow{b\alpha}) \circ \xrightarrow{a\gamma}_u \\
&\subseteq \xrightarrow{b\alpha} \circ \xrightarrow{a\gamma} \circ \xleftarrow{a\beta} \circ \xrightarrow{a\beta} \circ u' \xleftarrow{a\gamma} \circ (\xrightarrow{b\alpha} \circ \xrightarrow{a\gamma}_{u_1} \circ \xleftarrow{b\alpha}) && \text{by } 10.5^{op} \\
&\subseteq \xrightarrow{b\alpha} \circ \xrightarrow{a\gamma} \circ \xleftarrow{a\beta} \circ \xrightarrow{a\beta} \circ \xrightarrow{b\alpha} \circ u'_1 \xleftarrow{a\gamma} \circ \xleftarrow{b\alpha} \circ \xrightarrow{a\gamma}_{u_1} \circ \xleftarrow{b\alpha} && \text{by } 10.5 \\
&\subseteq \xrightarrow{b\alpha} \circ \xrightarrow{a\gamma} \circ \xleftarrow{a\beta} \circ \xrightarrow{a\beta} \circ u'_1 \xleftarrow{a\gamma} \circ \xleftarrow{b\alpha} \circ \xrightarrow{a\gamma}_{u_1} \circ \xleftarrow{b\alpha} && \text{by } 10.1\text{--}10.3
\end{aligned}$$

It seems that the matters become more complicate. However, a fine analysis show that we get a simplification. The simulation  $\xrightarrow{b\alpha}$  between  $u$  and  $u'$  (in the second line above) shows that the length of the source of the new morphism  $u_1$  does not exceed the length of  $u'$ ; moreover, if the lengths are equal, then the additional term  $\xrightarrow{b\alpha}$  disappear (it becomes a simulation via an isomorphism). Similarly, in the third line the length of the source of the new morphism  $u'_1$  does not exceed the length of the one of  $u_1$ . Hence, after a finite number of transformations as before we get

$$\begin{aligned} (F', F'') &\in \xrightarrow{b\alpha} \circ \xrightarrow{a\gamma} \circ \xleftarrow{a\beta} \circ \xrightarrow{a\beta} \circ u'_n \xleftarrow{a\gamma} \circ \xrightarrow{a\gamma}_{u_n} \xleftarrow{b\alpha} \\ &\subseteq \rho \end{aligned} \quad \text{by 8.1, 8.4, 8.6}$$

□

This theorem provides techniques to minimize flowgraphs with respect to the input-output behaviour. In this type of minimization the following reductions are used:

- $\xrightarrow{a\gamma}$  (identification of vertices having the same label and compatible outgoing connections),
- $\xleftarrow{a\beta}$  (deletion of vertices with no incoming paths from the entries of the flowgraph) and
- $\xrightarrow{b\alpha}$  (deletion of vertices with no outgoing paths to the exits of the flowgraph).

We get the following corollaries.

**Corollary 10.8** *Two  $\xleftrightarrow{b\delta}$ -equivalent and minimal flowgraphs are isomorphic.* □

**Corollary 10.9** *A flowgraph  $F$  is  $\xleftrightarrow{b\delta}$ -minimal if and only if ( $F \xrightarrow{a\gamma} F'$  or  $F \xleftarrow{a\beta} F'$  or  $F \xrightarrow{b\alpha} F'$ ) implies  $F \xrightarrow{a\alpha} F'$ .* □

## 10.2 Correctness of $b\delta$ -Flow-Calculus

Theorem 10.7 allows us to prove that the equivalence relation generated by simulation via  $b\delta$ -morphisms fulfills the enzymatic axiom.

**Theorem 10.10** *If  $T$  is a  $b\delta$ -flow obeying IP, then  $\mathbb{F}\ell_{b\delta}[X, T]$  satisfies condition  $\text{Enz}_{b\delta}$ .*

**Proof:** We use the same frame as in the proof of Theorem 8.15 Up to compositions with some bijections, every  $b\delta$ -morphism is of the type  $u \oplus \top_q$ , with  $u$  a  $b\gamma$ -morphisms. As in Theorem 8.15 the problem is reduced to the verification of the axiom  $\text{Enz}_{b\gamma}$ .

Let  $u : p \rightarrow q$  be a  $b\gamma$ -morphisms and  $F \in \mathbb{N}\mathbb{F}\ell[X, T](m \oplus p, n \oplus p)$  and  $G \in \mathbb{N}\mathbb{F}\ell[X, T](m \oplus q, n \oplus q)$  be two pairs such that

$$F \cdot (l_n \oplus u) \xleftrightarrow{b\delta} (l_m \oplus u) \cdot G$$

We may suppose that  $g = (\underline{x}, g)$  is a  $\xleftrightarrow{b\delta}$ -minimal pair. Then, it follows that  $(l_m \oplus u) \cdot G$  is a minimal pair, too. [The reason is as in the proof of 8.15 completed with the observation

that there exists an  $a\beta$ -morphism  $v : q \rightarrow p$  such that  $v \cdot u = l_q$ .] By Theorem 10.7 it follows that

$$F \cdot (l_n \oplus u) \xrightarrow{b\alpha} \circ \xrightarrow{a\gamma} \circ \xleftarrow{a\beta} (l_n \oplus u) \cdot G$$

and the desired result follows from Lemma 7.21 applied for  $A = b\delta$ ,  $B = a\alpha$ ,  $C = b\gamma$  and  $D = a\beta$ . [The verification of condition (3) in Lemma 7.21 in the case  $j$  is the  $b\gamma$ -morphism  $u$  is similar the the verification done for the case  $j = \vee_p^k$  in final part of the proof of Theorem 8.15.]  $\square$

**Corollary 10.11** ( $\xleftrightarrow{b\delta} = \sim_{b\delta}$ )

*The equivalence relation generated by simulation via  $b\delta$ -morphisms coincides with the equivalence relation with property  $Enz_{b\delta}$  generated by  $C_{b\delta}$ -var, shortly*

$$\xleftrightarrow{b\delta} = \sim_{b\delta} \quad \square$$

**Theorem 10.12** *It  $T$  is a  $b\delta$ -flow which obey condition IP, then  $\mathbb{F}\ell_{b\delta}[X, T]$  is a  $b\delta$ -flow, too.  $\square$*

It may be interesting to see whether the IP condition is necessary in order to prove that  $\mathbb{F}\ell_{b\delta}[X, T]$  is a  $b\delta$ -flow, and in an affirmative case to see if this condition is preserved by passing from  $T$  to  $\mathbb{F}\ell_{b\delta}[X, T]$ .

### 10.3 Completeness of $b\delta$ –Flow–Calculus with respect to the deterministic input-output behaviour

**Definition 10.13** (input-output (step-by-step) behaviour; — deterministic case)

We call the *input-output (step-by-step) behaviour* of a flowgraph the restriction of the input behaviour to the successful (= input-output) paths.  $\square$

Now we look for the meaning of  $b\delta$ -flownomials. In this case the algebra  $R_X^0$  proves to be useful. This algebra is obtained from the algebra  $R_X$  of rational trees by the identification of the subtrees without outputs to the empty tree. It is clear that the morphisms in  $R_X^0$  are in a bijective correspondence with the input-output behaviours of deterministic flowgraphs.

**Theorem 10.14** ( *$b\delta$ -flownomials = input-output behaviour of deterministic flowgraphs*)

*The algebras  $\mathbb{F}\ell_{EXP}[X, \mathbb{P}\text{fn}] / \sim_{b\delta}$ ,  $\mathbb{N}\mathbb{F}\ell[X, \mathbb{P}\text{fn}] / \xleftrightarrow{b\delta}$  and  $R_X^0$  are isomorphic.*

**Proof:** Let us first note that  $R_X^0$  is an  $b\delta$ -flow, hence  $b\delta$ -flownomials may be correctly interpreted in this theory, i.e. two flowgraphs that are equivalent using simulation via partially defined functions have equal interpretation.

Actually, the interpretation

$$\varphi^\sharp : \mathbb{F}\ell_{EXP}[X, \mathbb{P}\text{fn}] \rightarrow R_X^0$$

acts as follows: the flowgraphs are unfolded and then all the subtrees without outputs are identified to the empty tree. Now it is clear that for two n.f. expressions  $F_1$  and  $F_2$ ,

$$F_1 \xleftrightarrow{b\delta} F_2 \quad \Rightarrow \quad \varphi^\sharp(F_1) = \varphi^\sharp(F_2)$$

For  $i \in [2]$ , let  $F_i^{coacc}$  be the corresponding flowgraph obtained by deletion of the vertices with no outgoing paths to the exits of the flowgraph. It follows that

$F_i \xrightarrow{b\alpha} F_i^{coacc}$  and the unfoldment of  $F_i^{coacc}$  is  $\varphi^\sharp(F_i^{coacc})$ .

Consequently the unfoldment of  $F_1^{coacc}$  is equal to that of  $F_2^{coacc}$ . Using Theorem 8.13 we get

$$F_1^{coacc} \xleftrightarrow{a\delta} F_2^{coacc}$$

hence

$$F_1 \xleftrightarrow{b\delta} F_2$$

showing that  $\varphi^\sharp$  is injective.  $\square$

**Corollary 10.15** *The following conditions are equivalent for two flownomial expressions  $E$  and  $E'$  in  $\mathbb{F}\ell[X, \mathbb{Pfn}]$ :*

1.  $E \sim_{b\delta} E'$
2.  $\text{nf}(E) \xleftrightarrow{b\delta} \text{nf}(E')$
3. *The unfoldings of the flowgraphs associated to  $E$  and  $E'$  are the same, up to the replacement of the empty tree for subtrees without outputs.*  $\square$

## 10.4 Universality of $b\delta$ -flownomials

**Definition 10.16** Let us call the *input-output (step-by-step) behaviour* of a flowgraph the restriction of the input behaviour to the successful (= input-output) paths.  $\square$

Corollary 10.11 give:

**Theorem 10.17** (*universality of  $b\delta$ -flownomials*)

*If  $T$  is a  $b\delta$ -flow which obeys IP, then the statement obtained from that one of Theorem 8.20 by replacing everywhere  $a\delta$  with  $b\delta$  is valid.*  $\square$

Since  $\mathbb{Pfn}$  is also an initial  $b\delta$ -flow in the category of  $b\delta$ -flownomials, from the above theorem we get:

**Theorem 10.18**  $\mathbb{F}\ell_{b\delta}[X, T]$  *is the  $b\delta$ -flow freely generated by  $X$ .*  $\square$

## 10.5 Short comments and references

This is basically Chapter D, sec. 4–6 of [Ste91]. The results were announced in [Ste87a, CaS90a], but the detailed proofs were unpublished till now.

# Chapter 11

## Nondeterministic input-output behaviour ( $d\delta$ -flow)

In this chapter we study the input-output step-by-step behaviour of nondeterministic flowgraphs.

It is shown that the simulation via relations captures this type of behaviour. This is the key step in the proof of the completeness of the  $d\delta$ -flow axioms for this equivalence on flowgraphs.

The abstract correctness theorem (i.e., the preservation of the  $d\delta$ -flow structure when one passes from connections to the classes of equivalent flowgraphs) is proved with some mild assumptions: the matrix theory should be a zero-sum-free and uniform divisible one.

### 11.1 Characterization theorem for the equivalence $\overset{d\delta}{\iff}$ generated by simulation via relations

In the deterministic case the characterization theorem for both equivalences  $\overset{a\delta}{\iff}$  and  $\overset{b\delta}{\iff}$  where based on minimization. Very important here was the uniqueness, up to an isomorphism, of the minimal flownomials.

This idea cannot be used in the present nondeterministic case. As in the case of nondeterministic automata the minimization of nondeterministic flowgraphs is not completely understood: there are no criteria for the characterization of the minimality, no simple rules for minimization, etc. For example, the flownomials  $F' = x \cdot (\vee \cdot x \cdot \wedge) \uparrow$  and  $F'' = (\vee \cdot x \cdot \wedge) \uparrow \cdot x$  are  $\overset{d\delta}{\iff}$ -minimal, equivalent,<sup>1</sup> but not isomorphic.

So that for a characterization theorem for  $\overset{d\delta}{\iff}$ -equivalence we where forced to follow an oposite way: the characterization theorem given in this chapter shows that two flownomial expressions are  $\overset{d\delta}{\iff}$ -equivalent if and only if, making abstraction of some nonaccessible or noncoaccessible vertices, by partially unfolding the associated schemes (with respect to the inputs or the outputs) they may be refined to a common extension.

Actually, we shall prove that the following decomposition hold:

$$\overset{d\delta}{\iff} = \overset{a\beta}{\iff} \circ \overset{a\gamma}{\iff} \circ \overset{b\alpha}{\iff} \circ \overset{c\alpha}{\iff} \circ \overset{a\gamma}{\iff} \circ \overset{a\beta}{\iff} \circ \overset{c\alpha}{\iff} \circ \overset{b\alpha}{\iff}$$

---

<sup>1</sup>Both flownomials are equivalent with  $F = x \wedge ((\vee x \wedge) \uparrow \oplus 1_1) \vee x$ . More precisely,  $\text{nf}(F) \overset{a\gamma}{\iff} \text{nf}(F'')$  and  $\text{nf}(F) \overset{c\alpha}{\iff} \text{nf}(F')$ , where  $\text{nf}$  denotes the normal form application defined in Chapter 5.

In order to prove this theorem we need some lemmas of commutation between the elementary simulations that appear.

**Lemma 11.1**  $\xrightarrow{a\beta} \circ \xleftarrow{a\gamma} \subseteq \xleftarrow{a\gamma} \circ \xrightarrow{a\beta}$ , when  $T$  is a  $b\delta$ -ssmc which obeys IP.

**Proof:** Suppose

$$F' \xrightarrow{a\beta}_{u'} F \xleftarrow{a\gamma}_{u''} F''$$

Using isomorphic representations we may suppose

$$F' = (a, f'), F = (a \oplus b, f), F'' = (c \oplus d, f'') \text{ and} \\ u' = l_a \oplus \top_b, u'' = u_1 \oplus u_2 \text{ (with } u_1 : c \rightarrow a \text{)}$$

The simulations show that

$$(1) \quad f' \cdot (l_n \oplus i(l_a \oplus \top_b)) = (l_m \oplus o(l_a \oplus \top_b)) \cdot f \quad \text{and} \\ (2) \quad f'' \cdot (l_n \oplus i(u_1 \oplus u_2)) = (l_m \oplus o(u_1 \oplus u_2)) \cdot f$$

Take the pair

$$\overline{F} = (a, \overline{f}) \quad \text{where} \quad \overline{f} = (l_m \oplus o(l_c \oplus \top_d)) \cdot f'' \cdot (l_n \oplus i(l_c \oplus \perp^d))$$

We show that

$$F' \xleftarrow{a\gamma}_{u_1} \overline{F} \xrightarrow{a\beta}_{l_c \oplus \top_d} F''$$

The left part follows by an easy computation. For the right one, first note that

$$(l_m \oplus o(l_c \oplus \top_d)) \cdot f'' \cdot (l_n \oplus i(u_1 \oplus u_2)) = (l_m \oplus o(u_1 \oplus \top_b)) \cdot f \quad \text{by (2)} \\ = (l_m \oplus o(u_1)) \cdot f' \cdot (l_n \oplus i(l_a \oplus \top_b)) \quad \text{by (1)}$$

so that we may apply IP in order to infer that

$$(l_m \oplus o(l_c \oplus \top_d)) \cdot f'' = (l_m \oplus o(l_c \oplus \top_d)) \cdot f'' \cdot (l_n \oplus i(l_a \oplus \perp^d \cdot \top_d))$$

It follows that

$$\overline{f} \cdot (l_n \oplus i(l_c \oplus \top_d)) = (l_m \oplus o(l_c \oplus \top_d)) \cdot f'' \cdot (l_n \oplus i(l_a \oplus \perp^d \cdot \top_d)) \\ = (l_m \oplus o(l_c \oplus \top_d)) \cdot f''$$

□

**Lemma 11.2**  $\xrightarrow{b\alpha} \circ \xleftarrow{a\gamma} \subseteq \xleftarrow{a\gamma} \circ \xrightarrow{b\alpha}$ , when  $T$  is a  $d\alpha$ -strong  $d\gamma$ -ssmc.

**Proof:** Let

$$F' \xrightarrow{b\alpha}_{u'} F \xleftarrow{a\gamma}_{u''} F''$$

where

$$F' = (a \oplus b, f'), F = (a, f), F'' = (c, f'') \text{ and } u' = l_a \oplus \perp^b.$$

The simulations give

$$(1) \quad f' \cdot (l_n \oplus i(l_a \oplus \perp^b)) = (l_m \oplus o(l_a \oplus \perp^b)) \cdot f \quad \text{and}$$



$$(2) \quad f'' \cdot (l_n \oplus i(u'')) = (l_m \oplus o(u'')) \cdot f$$

Take the pair

$$\begin{aligned} \overline{F} &= (c \oplus b, \overline{f}), \quad \text{where} \\ \overline{f} &= \wedge^{m \oplus o(c \oplus b)} \cdot [ (l_m \oplus o(l_c \oplus \perp^b)) f'' \oplus (l_m \oplus o(u'' \oplus l_b)) f' (\perp^n \oplus i(\perp^a \oplus l_b)) ] \end{aligned}$$

We show that

$$F' \xrightarrow{u'' \oplus l_b} \overline{F} \xrightarrow{l_c \oplus \perp^b} F''$$

Indeed, for the right part one may see that

$$\begin{aligned} \overline{f} \cdot (l_n \oplus i(l_c \oplus \perp^b)) &= \wedge^{m \oplus o(c \oplus b)} \cdot [ (l_m \oplus o(l_c \oplus \perp^b)) f'' \oplus (l_m \oplus o(u'' \oplus l_b)) f' \cdot \perp^{n \oplus i(a \oplus b)} ] \\ &= \wedge^{m \oplus o(c \oplus b)} \cdot [ (l_m \oplus o(l_c \oplus \perp^b)) f'' \oplus \perp^{m \oplus o(c \oplus b)} ] \quad (\text{C}_{b\alpha}\text{-mor}) \\ &= (l_m \oplus o(l_c \oplus \perp^b)) \cdot f'' \end{aligned}$$

For the other one the computation is

$$\begin{aligned} \overline{f} \cdot (l_n \oplus i(u'' \oplus l_b)) &= \wedge^{m \oplus o(c \oplus b)} \cdot [ (l_m \oplus o(l_c \oplus \perp^b)) f'' (l_n \oplus i(u'')) \\ &\quad \oplus (l_m \oplus o(u'' \oplus l_b)) f' (\perp^n \oplus i(\perp^a \oplus l_b)) ] \\ &= \wedge^{m \oplus o(c \oplus b)} \cdot [ (l_m \oplus o(u'' \oplus \perp^b)) f \\ &\quad \oplus (l_m \oplus o(u'' \oplus l_b)) f' (\perp^n \oplus i(\perp^a \oplus l_b)) ] \quad \text{by (2)} \\ &= \wedge^{m \oplus o(c \oplus b)} \cdot [ (l_m \oplus o(u'' \oplus l_b)) f' (l_n \oplus i(l_a \oplus \perp^b)) \\ &\quad \oplus (l_m \oplus o(u'' \oplus l_b)) f' (\perp^n \oplus i(\perp^a \oplus l_b)) ] \quad \text{by (1)} \\ &= (l_m \oplus o(u'' \oplus l_b)) f' \cdot \wedge^{n \oplus o(a \oplus b)} \cdot [ l_n \oplus i(l_a \oplus \perp^b) \oplus \perp^n \oplus i(\perp^a \oplus l_b) ] \quad (\text{C}_{c\alpha}\text{-mor}) \\ &= (l_m \oplus o(u'' \oplus l_b)) \cdot f' \end{aligned}$$

□

For the remained lemmas of commutation we need some technical conditions. We suppose the monoid of channel types is  $\mathbb{N}$  and the support theory is a matrix theory. As we have said in Proposition 3.8 such a theory may be seen as a theory of matrices over the semiring

$$(T(1, 1), \cup, \cdot, 0, 1)$$

where

$$f \cup g = \perp^1 \cdot (f \oplus g) \cdot \top_1, \quad 0 = \perp^1 \cdot \top_1, \quad 1 = l_1.$$

Notice that in  $T$  the composition of matrices coincides with the usual product of matrices.

**Definition 11.3** (divisible and zero-sum-free semirings)

1. A semiring  $(S, \cup, \cdot, 0, 1)$  is *divisible* if for every  $a_1, a_2, b_1, b_2 \in S$ , if

$$a_1 \cup a_2 = b_1 \cup b_2$$

then there exist some elements in  $S$ , denoted  $a_i \& b_j$ , for  $i, j \in [2]$ , such that

$$\sum_{j \in [2]} a_i \& b_j = a_i, \quad \forall i \in [2] \quad \text{and} \quad \sum_{i \in [2]} a_i \& b_j = b_j, \quad \forall j \in [2]$$

2. A semiring  $S$  is *zero-sum-free* if for every  $a_1, a_2 \in S$ :

$$a_1 \cup a_2 = 0 \quad \Rightarrow \quad a_1 = 0 \quad \text{and} \quad a_2 = 0$$

□

From the implication that defines the divisibility condition one may deduce that the following more general implication hold:

(\*) If  $I, J$  are finite nonempty sets, then for every families of elements  $a_i \in S(i \in I)$  and  $b_j \in S(j \in J)$ : If

$$\sum_{i \in I} a_i = \sum_{j \in J} b_j$$

then there exist some elements in  $S$ , denoted  $a_i \& b_j$  for  $i \in I$  and  $j \in J$ , such that

$$\sum_{j \in J} a_i \& b_j = a_i, \quad \forall i \in I \quad \text{and} \quad \sum_{i \in I} a_i \& b_j = b_j, \quad \forall j \in J$$

If we use the convention that the sum over the empty set is zero, then the zero-sum-free condition is an extreme case of the implication (\*), namely when  $I = \{1, 2\}$  and  $J = \emptyset$ . So that

in a zero-sum-free and divisible semiring the implication (\*) holds for arbitrary finite sets  $I$  and  $J$ .

Finally, we say a matrix theory  $T$  is divisible or zero-sum-free if the associated semiring  $(T(1, 1), \cup, \cdot, 0, 1)$  has the corresponding property. In a standard componentwise way property (\*) is extended to matrices.

In the case our support theory is a matrix theory we speak about the *standard splitting of the representation of flowgraphs*: if we have a pair  $(x_1 \oplus \dots \oplus x_p, f)$ , then we write the connection morphism  $f \in T(m \oplus o(x_1) \oplus \dots \oplus o(x_p), n \oplus i(x_1) \oplus \dots \oplus i(x_p))$  as

$$\left[ \begin{array}{c|ccc} A & B_1 & \dots & B_p \\ \hline C_1 & D_{11} & \dots & D_{1p} \\ \vdots & \vdots & \ddots & \vdots \\ C_p & D_{p1} & \dots & D_{pp} \end{array} \right]$$

where

$$\begin{aligned} A &\in T(m, n) \\ B_k &\in T(m, i(x_k)) \quad \forall k \in [p] \\ C_j &\in T(o(x_j), n) \quad \forall j \in [p] \\ D_{jk} &\in T(o(x_j), i(x_k)) \quad \forall j \in [p], k \in [p] \end{aligned}$$

The proof of the next lemmas may be found in [Ste87a].

**Lemma 11.4**  $\xrightarrow{a\gamma} \circ \xleftarrow{a\gamma} \subseteq \xleftarrow{a\gamma} \circ \xrightarrow{a\gamma}$ , when  $T$  is a divisible matrix theory.

**Proposition 11.5** (*interpolation property*)

1. If  $A$  and  $B$  are matrices over a zero-sum-free and divisible semiring and  $u$  and  $v$  are functions (considered as  $\{0, 1\}$ -matrices) such that  $A \cdot u^{-1} \cdot v = u^{-1} \cdot v \cdot B$ , then there exists a matrix  $Z$  over  $S$  such that  $A \cdot u^{-1} = u^{-1} \cdot Z$  and  $Z \cdot v = v \cdot B$ .
2. If the functions  $u$  and  $v$  are surjective, then the property in (i) holds using only the divisible property of  $S$ .

**Lemma 11.6**  $\xrightarrow{d\delta} \subseteq \xrightarrow{b\alpha} \circ \xrightarrow{c\alpha} \circ \xrightarrow{a\gamma} \circ \xrightarrow{a\beta}$ , when  $T$  is a zero-sum-free and divisible matrix theory.

In a similar way it follows that  $\xrightarrow{c\gamma} \subseteq \xrightarrow{c\alpha} \circ \xrightarrow{a\gamma}$ , hence

**Lemma 11.7**  $\xrightarrow{a\gamma} \circ \xrightarrow{c\alpha} \subseteq \xrightarrow{c\gamma} \subseteq \xrightarrow{c\alpha} \circ \xrightarrow{a\gamma}$ , when  $T$  is a divisible matrix theory.

The last type of commutation remained to be studied  $\xrightarrow{c\alpha} \circ \xleftarrow{a\gamma} \subseteq \xleftarrow{a\gamma} \circ \xrightarrow{c\alpha}$  does not hold in the general case.

However, we will find a useful commutation which adds a parasite term. For this we need a condition stronger than divisibility, which we call uniform divisibility.

**Definition 11.8** (uniform-divisible semirings)

A semiring  $(S, \cup, \cdot, 0, 1)$  is *uniform divisible* if there is an operation  $\cap : S \times S \rightarrow S$  fulfilling the following axioms:<sup>2</sup>

- (As)  $x \cap (y \cap z) = (x \cap y) \cap z$
- (C)  $x \cap y = y \cap x$
- (D)  $(x \cup y) \cap z = (x \cap z) \cup (y \cap z)$
- (A)  $(x \cup y) \cap x = x$

A matrix theory  $T$  is *uniform divisible* if its associated semiring  $(T(1, 1), \cup, \cdot, 0, 1)$  is uniform divisible; in such a case the componentwise extension of “ $\cap$ ” to matrices is denoted by the same sign.  $\square$

It is obvious that uniform divisibility implies divisibility.<sup>3</sup>

**Lemma 11.9**  $\xrightarrow{c\alpha} \circ \xleftarrow{a\gamma} \subseteq \xleftarrow{a\gamma} \circ \xrightarrow{c\alpha} \circ \xrightarrow{a\gamma}$ , when  $T$  is a uniform divisible matrix theory.

Before collecting the results we made an observation. When  $T$  is a matrix theory condition IP follows from the zero-sum-free condition. Indeed, if  $f = [A \ B] \in T(r, m+n)$  and  $u : m \rightarrow p$ ,  $v : n \rightarrow q$  are surjections, then condition IP is

$$f \cdot (u \oplus v) = f' \cdot (l_p \oplus \top_q) \quad \Rightarrow \quad f = f \cdot (l_m \oplus \perp^n \cdot \top_n)$$

and may be written as (we suppose  $B : r \rightarrow n$ )

$$[Au \ Bv] = [A' \ 0_{r,q}] \quad \Rightarrow \quad [A \ B] = [A \ 0_{r,n}]$$

<sup>2</sup>Actually this means that  $(S, \cup, \cap)$  is a lattice.

<sup>3</sup>For the converse, we note that at the present we do not know examples of interesting divisible semirings which cannot be made uniform divisible.

Table 11.1: Is  $x \circ y \subseteq y \circ x$ ? (case  $d\delta$ )

$y$ $x$	$\xleftarrow{a\beta}$	$\xleftarrow{a\gamma}$	$\xrightarrow{b\alpha}$	$\xrightarrow{c\alpha}$	$\xrightarrow{a\gamma}$	$\xrightarrow{a\beta}$	$\xleftarrow{c\alpha}$	$\xleftarrow{b\alpha}$
$\xleftarrow{a\beta}$	Obv.							
$\xleftarrow{a\gamma}$	8.1 <sup>op</sup>	Obv.						
$\xrightarrow{b\alpha}$	10.3 <sub>o</sub>	11.2	Obv.					
$\xrightarrow{c\alpha}$	(*10.5 <sub>o</sub> )	(*11.9)	8.1 <sup>op</sup> <sub>o</sub>	Obv.				
$\xrightarrow{a\gamma}$	11.2 <sup>op</sup>	11.4	10.1	11.7	Obv.			
$\xrightarrow{a\beta}$	8.3 <sup>o</sup>	11.1	10.2	10.5 <sup>op</sup> <sub>o</sub>	8.1	Obv.		
$\xleftarrow{c\alpha}$	10.1 <sub>o</sub>	11.7 <sup>op</sup>	11.1 <sup>op</sup> <sub>o</sub>	11.4 <sub>o</sub>	(*11.9 <sup>op</sup> <sub>o</sub> )	11.2 <sup>op</sup> <sub>o</sub>	Obv.	
$\xleftarrow{b\alpha}$	10.2 <sup>op</sup>	10.1 <sup>op</sup>	8.3 <sub>o</sub>	11.1 <sub>o</sub>	(*10.5 <sup>op</sup> <sub>o</sub> )	10.3 <sup>op</sup>	8.1 <sub>o</sub>	Obv.

It follows that IP is implied by

$$Bv = 0 \quad \Rightarrow \quad B = 0$$

for the surjection  $v$ . Using permutations we may suppose  $v = \vee_1^{n_1} \oplus \dots \oplus \vee_1^{n_q}$  and moreover,  $q = 1$  in which case the last implication is

$$b_1 \cup \dots \cup b_k = 0 \quad \Rightarrow \quad [b_1 \dots b_k] = 0$$

and follows from the zero-sum-free property.

**Theorem 11.10** (characterization theorem for  $\xleftrightarrow{d\delta}$ )

If  $T$  is a zero-sum-free and uniform divisible matrix theory, then in  $\mathbb{F}\ell[X, T]$  the following decomposition holds:

$$\xleftrightarrow{d\delta} = \xleftarrow{a\beta} \circ \xleftarrow{a\gamma} \circ \xrightarrow{b\alpha} \circ \xrightarrow{c\alpha} \circ \xrightarrow{a\gamma} \circ \xrightarrow{a\beta} \circ \xleftarrow{c\alpha} \circ \xleftarrow{b\alpha} .$$

**Proof:** The inclusion “ $\supseteq$ ” is obviously valid.

For the other one, let  $\rho$  denote the right hand side of the identity to prove. By Lemma 11.6 it follows that

$$\xleftrightarrow{d\delta} \subset \rho^+$$

Consequently it is enough to prove that  $\rho$  is transitive, i.e. all the relations

$$\rho \circ \xleftarrow{a\beta}, \rho \circ \xleftarrow{a\gamma}, \rho \circ \xrightarrow{b\alpha}, \rho \circ \xrightarrow{c\alpha}, \rho \circ \xrightarrow{a\gamma}, \rho \circ \xrightarrow{a\beta}, \rho \circ \xleftarrow{c\alpha}, \text{ and } \rho \circ \xleftarrow{b\alpha}$$

are included in  $\rho$ . All the inclusions, except for

$$\rho \circ \xrightarrow{a\gamma}, \rho \circ \xleftarrow{a\gamma}, \text{ and } \rho \circ \xleftarrow{a\beta}$$

directly follows from (the transitivity of relations  $\xleftarrow{a\beta}$ ,  $\xleftarrow{a\gamma}$ , etc. and) the commutation displayed in Table 11.1. In the excepted cases we use Lemmas 10.5, 11.9 and their duals. These lemmas give the necessary commutations but add some auxiliary terms, which, fortunately, may be eliminated using the commutations in Table 11.1 and the transitivity of the elementary simulations  $\xrightarrow{a\beta}$ , etc.  $\square$

## 11.2 Correctness of $d\delta$ –Flow–Calculus with respect to the nondeterministic input-output behaviour

Theorem 11.10 allows us to prove that the equivalence relation generated by simulation via  $b\delta$ -morphisms fulfills the enzymatic axiom.

**Theorem 11.11** *If  $T$  is a zero-sum-free and uniform-divisible  $d\delta$ -flow, then  $\mathbb{F}\ell_{d\delta}[X, T]$  satisfies condition  $\text{Enz}_{d\delta}$ .*

**Proof:** Theorem 11.10 shows that

$$\left\langle \begin{array}{c} d\delta \\ \hline \end{array} \right\rangle = \leftarrow^{a\delta} \circ \xrightarrow{d\delta} \circ \leftarrow^{d\alpha}$$

The statement in the theorem follows from Lemma 7.21 applied for  $A = d\delta$ ,  $B = a\delta$ ,  $C = d\delta$  and  $D = d\alpha$ . Condition (2) in Lemma 7.21 is obviously satisfied (the proof is as in the final proof of Theorem 8.15). Since  $B^o = D$  condition (3) is dual to condition (2), hence it is also valid.  $\square$

**Corollary 11.12**  $(\left\langle \begin{array}{c} d\delta \\ \hline \end{array} \right\rangle = \sim_{d\delta})$

*The equivalence relation generated by simulation via  $d\delta$ -morphisms coincides with the equivalence relation with property  $\text{Enz}_{d\delta}$  generated by  $(C_{d\delta}\text{-var})$ , shortly*

$$\left\langle \begin{array}{c} d\delta \\ \hline \end{array} \right\rangle = \sim_{d\delta} \quad \square$$

**Theorem 11.13** *If  $T$  is a zero-sum-free and uniform-divisible  $d\delta$ -flow, then  $\mathbb{F}\ell_{d\delta}[X, T]$  is a  $d\delta$ -flow, too.  $\square$*

As in the previous case  $b\delta$  it is still open whether the additional conditions (zero-sum-freeness and uniform-divisibility) are necessary in order to prove that  $\mathbb{F}\ell_{d\delta}[X, T]$  is a  $d\delta$ -flow, and in an affirmative case to see if these conditions are preserved by passing from  $T$  to  $\mathbb{F}\ell_{d\delta}[X, T]$ .

## 11.3 Completeness of $d\delta$ –Flow–Calculus with respect to the nondeterministic input-output behaviour

*The aim of this section is to show that the equivalence relation generated by simulation via  $d\delta$ -morphisms (= relations) captures the input-output (step-by-step) behaviour of nondeterministic flowgraphs.*

By Corollary 7.19  $\mathbb{F}\ell_{d\delta}[X, T]$  is a matrix theory, hence we may suppose  $X$  has only one-input/one-output variables. Moreover, since every flowgraph  $F : p \rightarrow q$  is equivalent via  $d\delta$ -morphisms to the matrix  $(F_{i,j})_{i \in [p], j \in [q]}$  of its components and two flowgraphs  $F, F' : p \rightarrow q$  have the same successful computation sequences if and only if for every  $i \in [p], j \in [q]$  the components  $F_{i,j}$  and  $F'_{i,j}$  have the same set of successful computation sequences, it follows that it is enough to prove the result for flowgraphs with one input and one output.

**Definition 11.14** (semideterministic flowgraphs)

We say a flowgraph  $F : p \rightarrow q$  over  $\mathbb{R}\text{el}$  and  $X$ <sup>4</sup>

$$F = \begin{matrix} & & & \left( \begin{array}{ccc|ccc} A_{11} & \dots & A_{1q} & B_{11} & \dots & B_{1n} \\ \vdots & & \vdots & \vdots & & \vdots \\ A_{p1} & \dots & A_{pq} & B_{p1} & \dots & B_{pn} \\ \hline C_{11} & \dots & C_{1q} & D_{11} & \dots & D_{1n} \\ \vdots & & \vdots & \vdots & & \vdots \\ C_{n1} & \dots & C_{nq} & D_{n1} & \dots & D_{nn} \end{array} \right) \\ x_1 & & & & & \\ \vdots & & & & & \\ x_n & & & & & \end{matrix}$$

is *semideterministic* if

1.  $\forall i \in [p], \forall j, k \in [n] \quad [j \neq k \wedge B_{ij} = B_{ik} = 1 \Rightarrow x_j \neq x_k]$  and
2.  $\forall i \in [n], \forall j, k \in [n] \quad [j \neq k \wedge D_{ij} = D_{ik} = 1 \Rightarrow x_j \neq x_k]$ .

□

In other words, a semideterministic flowgraph still may be nondeterministic, but the possible multiple ways of continuation of the flow are referred to vertices labeled with distinct variables or to distinct outputs.

### 11.3.1 Reduction of nondeterministic flowgraphs to semideterministic ones

The following result is an adaptation to the case of flowgraphs of a known result in automata theory which states that a nondeterministic automaton is “similar” to the associated deterministic automaton obtained by the standard power-set construction, see [Koz91, BIEs92].

**Lemma 11.15** *For every nondeterministic flowgraph  $F \in \text{NF}\ell[X, \mathbb{R}\text{el}](p, q)$  there is a semideterministic one  $SD(F) \in \text{NF}\ell[X, \mathbb{R}\text{el}](p, q)$  and a relation  $u$  such that  $SD(F) \xrightarrow{u} F$ .*

**Proof:** Let  $V = \{x_1, \dots, x_m\}$  be the set of variables that occur in  $F$ . As the set of indices for the vertices of  $F$  we use the set

$$I = \{(i, j) : i \in [m], j \in [n_i]\}, \quad \text{with } n_i \geq 1, \forall i \in [m]$$

and the variable associated with such an index  $(i, j)$  is  $x_i$  (hence  $n_i$  gives the number of the occurrences of the variable  $x_i$  in  $F$ ). Finally, suppose the matrix of connections of  $F$  is

$$\left( \begin{array}{c|c} A & B \\ \hline C & D \end{array} \right)$$

splitted in a standard way with respect to the inputs and the outputs.

We built up the flowgraph  $SD(F)$  in the following way:

---

<sup>4</sup> $X$  is supposed to have only  $1 \rightarrow 1$  variables.

- As the set of indices for the vertices of  $SD(F)$  we take

$$\bar{I} = \{(i, P) : i \in [m] \text{ and } \emptyset \neq P \subseteq [n_i]\}$$

and associate the variable  $x_i$  to such an index  $(i, P)$ ;

- The matrix of connections, denoted  $\left( \begin{array}{c|c} \bar{A} & \bar{B} \\ \hline \bar{C} & \bar{D} \end{array} \right)$ , is defined by

$$- \bar{A} = A$$

$$- \forall r \in [p], \forall (j, Q) \in \bar{I} \text{ define}$$

$$\bar{B}_{r,(j,Q)} = 1 \text{ iff } Q = \{l \in [n_j] : B_{r,(j,l)} = 1\}$$

$$- \forall (i, P) \in \bar{I}, \forall s \in [q] \text{ define}$$

$$\bar{C}_{(i,P),s} = \sum_{k \in P} C_{(i,k),s}$$

$$- \forall (i, P) \in \bar{I}, \forall (j, Q) \in \bar{I} \text{ define}$$

$$\bar{D}_{(i,P),(j,Q)} = 1 \text{ iff } Q = \{l \in [n_j] : \exists k \in P \text{ such that } D_{(i,k),(j,l)} = 1\}$$

We show that the relation  $u \subseteq \bar{I} \times I$  defined by

$$u = \{\langle (i, P), (i, j) \rangle : (i, P) \in \bar{I}, (i, j) \in I \text{ and } j \in P\}$$

gives the required simulation, i.e.

$$SD(F) \xrightarrow{u} F$$

It is clear that  $U$  preserve the variables, hence it is enough to show that

$$\left( \begin{array}{c|c} \bar{A} & \bar{B}u \\ \hline \bar{C} & \bar{D}u \end{array} \right) = \left( \begin{array}{cc} A & B \\ uC & uD \end{array} \right)$$

1. By definition  $\bar{A} = A$ .
2. For checking the equality  $\bar{C} = uC$  take  $(i, P) \in \bar{I}$  and  $s \in [q]$ . The corresponding element in the matrix  $uC$  is

$$\sum_{(i,k) \in I \text{ such that } \langle (i,P), (i,k) \rangle \in u} C_{(i,k),s} = \sum_{k \in P} C_{(i,k),s}$$

and is equal by definition to the corresponding element in  $\bar{C}$ , namely

$$\bar{C}_{(i,P),s}.$$

3. For checking the equality  $\overline{B}u = B$  take  $r \in [p]$  and  $(j, l) \in I$ . The corresponding element in  $\overline{B}u$  is

$$\sum_{(j, Q) \in \overline{I} \text{ such that } \langle (j, Q), (j, l) \rangle \in u} \overline{B}_{r, (j, Q)} = \sum_{Q \ni l} \overline{B}_{r, (j, Q)} \quad (11.1)$$

and in  $B$  is

$$B_{r, (j, l)} \quad (11.2)$$

By a double inclusion we show the sums in the right-hand-side of 11.1 and 11.2 are equal:

- If

$$\sum_{Q \ni l} \overline{B}_{r, (j, Q)} = 1$$

then there exists  $Q_0 \ni l$  such that

$$(j, Q_0) \in \overline{I} \quad \text{and} \quad \overline{B}_{r, (j, Q_0)} = 1$$

From the definition of  $\overline{B}$  it follows that

$$Q_0 = \{l' \in [n_j] : B_{r, (j, l')} = 1\}$$

Since  $l \in Q_0$ , we have

$$B_{r, (j, l)} = 1$$

- Conversely, if

$$B_{r, (j, l)} = 1$$

then the set

$$Q_0 = \{l' \in [n_j] : B_{r, (j, l')} = 1\}$$

is nonempty (it contains  $l$ ), hence

$$(j, Q_0) \in \overline{I}$$

From the definition of  $\overline{B}$  it follows that

$$\overline{B}_{r, (j, Q_0)} = 1$$

Since  $l \in Q_0$  we have

$$\sum_{Q \ni l} \overline{B}_{r, (j, Q)} = 1$$

4. Finally, for the last equality  $\overline{D}u = uD$  take  $(i, P) \in \overline{I}$  and  $(j, l) \in I$ . The corresponding component in  $\overline{D}u$  is

$$\sum_{(j, Q) \in \overline{I} \text{ such that } \langle (j, Q), (j, l) \rangle \in u} \overline{D}_{(i, P), (j, Q)} = \sum_{Q \ni l} \overline{D}_{(i, P), (j, Q)} \quad (11.3)$$

and in  $uD$  is

$$\sum_{(i, k) \in I \text{ such that } \langle (i, P), (i, k) \rangle \in u} D_{(i, k), (j, l)} = \sum_{k \in P} D_{(i, k), (j, l)} \quad (11.4)$$

As before we show the sums in the right-hand-side of 11.3 and 11.4 are equal:



- If

$$\sum_{Q \ni l} \overline{D}_{(i,P),(j,Q)} = 1$$

there exists  $Q_0 \ni l$  such that

$$(j, Q_0) \in \overline{I} \quad \text{and} \quad \overline{D}_{(i,P),(j,Q_0)} = 1$$

From the definition of  $\overline{D}$  it follows that

$$Q_0 = \{l' \in [n_j] : \exists k \in P \text{ such that } D_{(i,k),(j,l')} = 1\}$$

As  $l \in Q_0$  there exists  $k_0 \in P$  such that

$$D_{(i,k_0),(j,l)} = 1$$

hence

$$\sum_{k \in P} D_{(i,k),(j,l)} = 1$$

- Conversely, if

$$\sum_{k \in P} D_{(i,k),(j,l)} = 1$$

there exist  $k_0 \in P$  such that

$$D_{(i,k_0),(j,l)} = 1$$

It follows that the set

$$Q_0 = \{l' \in [n_j] : \exists k \in P \text{ such that } D_{(i,k),(j,l')} = 1\}$$

is nonempty (it contains  $l$ ), hence

$$(j, Q_0) \in \overline{I}$$

Using the definition of  $\overline{D}$  we get

$$\overline{D}_{(i,P),(j,Q_0)} = 1$$

Since  $l \in Q_0$  we have

$$\sum_{Q \ni l} \overline{D}_{(i,P),(j,Q)} = 1$$

□

The next step consists in the transformation of a semideterministic flowgraph into a deterministic one having a nicely related behaviour. Before this we give some details for the definition of the input-output behaviour of flowgraphs.

### 11.3.2 Formalisation of the input–output behaviour

The *input-output (step-by-step) behaviour* may be defined by giving an interpretation of the flownomial expressions in a particular matrix theory. More precisely, if  $X = \{X(m, n)\}_{m, n \in \mathbb{N}}$  is a set of doubly-ranked variables, then we associate the set

$$\langle X \rangle$$

obtained taking  $m \times n$  new variables for each  $x \in X(m, n)$ , denoted

$$\langle i, x, j \rangle$$

with  $i \in [m]$ ,  $j \in [n]$ . (The new variable  $\langle i, x, j \rangle$  denotes the flowgraph obtained taking the restriction of the atomic flowgraph  $x$  to its  $i$ -th input and  $j$ -th output.)

We built up the theory of usual matrices

$$\mathcal{M}(\mathcal{P}(\langle X \rangle^*))$$

over the semiring  $(\mathcal{P}(\langle X \rangle^*), \cup, \cdot, \emptyset, \{\lambda\})$  of subsets of words in  $\langle X \rangle^*$  with the standard operations (union and composition, i.e.  $A \cdot A' = \{ww' : w \in A, w' \in A'\}$ ) and the standard constants (the empty set and the set consisting of the empty word  $\lambda$ , only).

Let us note by  $\smile$  the unique morphism of matrix theories

$$\smile : \mathbb{R}el \rightarrow \mathcal{M}(\mathcal{P}(\langle X \rangle^*))$$

that is, the one that maps a relation, –considered as a matrix over 0 and 1 –, to the matrix obtained by replacing everywhere 0 and 1 by  $\emptyset$  and  $\{\lambda\}$ , respectively. Finally, denote by  $\psi$  the function that interpretes a variable  $x \in X(m, n)$  as the matrix, i.e.

$$\psi(x) = \begin{pmatrix} \langle 1, x, 1 \rangle & \dots & \langle 1, x, n \rangle \\ \vdots & & \vdots \\ \langle m, x, 1 \rangle & \dots & \langle m, x, n \rangle \end{pmatrix} \in \mathcal{M}(\mathcal{P}(\langle X \rangle^*))(m, n)$$

Then, there is a unique application

$$\|\cdot\| : \mathbb{N}F\ell[X, \mathbb{R}el] \rightarrow \mathcal{M}(\mathcal{P}(\langle X \rangle^*))$$

that preserves the operations and extends the pair  $(\smile, \psi)$ .

Let  $F \in \mathbb{N}F\ell[X, \mathbb{R}el](p, q)$ . The matrix

$\|F\|$  represents the input-output behaviour of the flowgraph  $F$ ,

more precisely, the component  $F_{i,j}$  of the matrix  $\|F\|$  is the set of all the succesful computation sequences of  $F$  starting with the  $i$ -th input and ending at the  $j$ -th output.

In order to prove this fact, let us suppose that

$$F = [(l_p \oplus x_1 \oplus \dots \oplus x_k) \cdot f] \uparrow^{m_1 + \dots + m_k}$$

where  $x_i \in X(m_i, n_i)$ ,  $\forall i \in [k]$ . Write the matrix  $f$  as follows

$$\begin{pmatrix} A & B_1 & \dots & B_k \\ C_1 & D_{11} & \dots & D_{1k} \\ \vdots & \vdots & & \vdots \\ C_k & D_{k1} & \dots & D_{kk} \end{pmatrix}$$

where the entries of the matrix are matrices of the following dimensions:

$$\begin{aligned}
A &: p \rightarrow q & B_1 &: p \rightarrow m_1 & \dots & B_k &: p \rightarrow m_k \\
C_1 &: n_1 \rightarrow q & D_{11} &: n_1 \rightarrow m_1 & \dots & D_{1k} &: n_1 \rightarrow m_k \\
&\vdots & & & & & \\
C_k &: n_k \rightarrow q & D_{k1} &: n_k \rightarrow m_1 & \dots & D_{kk} &: n_k \rightarrow m_k
\end{aligned}$$

With these notations we may write

$$\begin{aligned}
\|F\| &= [(l_p \oplus \psi(x_1) \oplus \dots \oplus \psi(x_k)) \cdot \check{f}] \uparrow^{m_1+\dots+m_k} \\
&= \left( \begin{array}{cccc} \check{A} & \check{B}_1 & \dots & \check{B}_k \\ \psi(x_1)\check{C}_1 & \psi(x_1)\check{D}_{11} & \dots & \psi(x_1)\check{D}_{1k} \\ \vdots & \vdots & & \vdots \\ \psi(x_k)\check{C}_k & \psi(x_k)\check{D}_{k1} & \dots & \psi(x_k)\check{D}_{kk} \end{array} \right) \uparrow^{m_1+\dots+m_k} \\
&= \check{A} \cup [\check{B}_1 \dots \check{B}_k] \cdot \left( \begin{array}{ccc} \psi(x_1)\check{D}_{11} & \dots & \psi(x_1)\check{D}_{1k} \\ \vdots & & \vdots \\ \psi(x_k)\check{D}_{k1} & \dots & \psi(x_k)\check{D}_{kk} \end{array} \right)^* \cdot \left( \begin{array}{c} \psi(x_1)\check{C}_1 \\ \vdots \\ \psi(x_k)\check{C}_k \end{array} \right)
\end{aligned}$$

Let us note that the matrices of the type  $\check{A}$ ,  $\check{B}$ ,  $\check{C}$  and  $\check{D}$  have the components of the forms  $\emptyset$  or  $\{\lambda\}$  and only the matrices  $\psi(x_1), \dots, \psi(x_k)$  have nontrivial components, more precisely of the form  $\{\sigma\}$ , with  $\sigma$  in  $\langle X \rangle$ .

The star matrix has the dimension  $m_1 + \dots + m_k$ , hence their coordinates may be given by pairs  $\langle i, r \rangle$ , with  $i \in [k]$  and  $r \in [m_i]$  that specify the  $r$ -th component of the  $i$ -th block. Let us use the notation

$$E^{i,j}$$

for the entry of a matrix  $E$  corresponding to the  $i$ -th row and the  $j$ -th columns.

From the formula that we have got above for the computation of  $\|F\|$  it follows that a word

$$w \in F_{ij}$$

if and only if

- (A)  $w = \lambda$  and  $\lambda \in (\check{A})^{i,j}$  or
- (B) there exist indices  $\langle i_1, r_1 \rangle, \dots, \langle i_n, r_n \rangle$  ( $n \geq 1$ ) specifying elements in  $[m_1 + \dots + m_k]$  such that  $w = w_1 \dots w_n$  and
  - (a)  $\lambda \in (\check{B}_{i_1})^{i,r_1}$
  - (b)  $w_1 \in (\psi(x_{i_1})\check{D}_{i_1 i_2})^{r_1, r_2}, \dots, w_{n-1} \in (\psi(x_{i_{n-1}})\check{D}_{i_{n-1} i_n})^{r_{n-1}, r_n}$
  - (c)  $w_n \in (\psi(x_{i_n})\check{C}_{i_n})^{r_n, j}$ .

From (b) and (c) it follows that there exist elements  $s_1 \in [n_1], \dots, s_n \in [n_n]$  such that

- $w_1 \in \psi(x_{i_1})^{r_1, s_1} \ \& \ \lambda \in (\check{D}_{i_1 i_2})^{s_1, r_2};$
- $\vdots;$
- $w_{n-1} \in \psi(x_{i_{n-1}})^{r_{n-1}, s_{n-1}} \ \& \ \lambda \in (\check{D}_{i_{n-1} i_n})^{s_{n-1}, r_n};$

- $w_n \in \psi(x_{i_n})^{r_n, s_n}$  &  $\lambda \in (\check{C}_{i_n})^{s_n, j}$ .

From this, the following form of the above condition follows:

A word  $w$  is in  $F_{ij}$  if and only if

1.  $w = \lambda$  and  $(i, j) \in A$  or
2.  $w = \langle r_1, x_{i_1}, s_1 \rangle \langle r_2, s_{i_2}, s_2 \rangle \dots \langle r_n, x_{i_n}, s_n \rangle$  such that  
 $(i, r_1) \in B_{i_1}$ ,  $(s_1, r_2) \in D_{i_1 i_2}$ ,  $\dots$ ,  $(s_{n-1}, r_n) \in D_{i_{n-1} i_n}$ ,  $(s_n, j) \in C_{i_n}$ .<sup>5</sup>

If we come back to the given  $f$ , then the above condition may be written in the following form:

$$w \in F_{ij}$$

if and only if

1.  $w = \lambda$  and  $(i, j) \in f$  or
2.  $w = \langle r_1, x_{i_1}, s_1 \rangle \langle r_2, x_{i_2}, s_2 \rangle \dots \langle r_n, x_{i_n}, s_n \rangle$  such that  
 $\forall l \in [n]$  we have  $r_l \in [i(x_{i_l})]$  and  $s_l \in [o(x_{i_l})]$  and
  - (a)  $(i, q + i(x_1 \oplus \dots \oplus x_{i_1-1}) + r_1) \in f$ ,
  - (b)  $(p + o(x_1 \oplus \dots \oplus x_{i_1-1}) + s_1, q + i(x_1 \oplus \dots \oplus x_{i_2-1}) + r_2) \in f$ ,
  - $\vdots$ ,
  - $(p + o(x_1 \oplus \dots \oplus x_{i_{n-1}-1}) + s_{n-1}, q + i(x_1 \oplus \dots \oplus x_{i_n-1}) + r_n) \in f$ ,
  - (c)  $(p + o(x_1 + \dots + x_{i_n-1}) + s_n, j) \in f$ .

This condition may be read in the following form: A sequence

$$w \in F_{ij}$$

if and only if:

- it is the empty sequence and there exists an arrow in  $F$  from the  $i$ -th input of  $F$  to the  $j$ -th output, or
- there exist indices  $i_1, \dots, i_n \in [k]$  such that  $w = \langle r_1, x_{i_1}, s_1 \rangle \langle r_2, x_{i_2}, s_2 \rangle \dots \langle r_n, x_{i_n}, s_n \rangle$  for some values  $r_l \in [i(x_{i_l})]$ ,  $s_l \in [o(x_{i_l})]$  ( $l \in [n]$ ) and in the flowgraph  $F$  there exist:
  - an arrow from the  $i$ -th input of the flowgraph to the  $r_1$ -th input of variable  $x_{i_1}$ ;
  - an arrow from the  $s_1$ -th output of the variable  $x_{i_1}$  to the  $r_2$ -th input of  $x_{i_2}$ ;
  - $\vdots$ ;
  - an arrow from the  $s_{n-1}$ -th output of the variable  $x_{i_{n-1}}$  to the  $r_n$ -th input of  $x_{i_n}$ ;
  - an arrow from the  $s_n$ -th output of the variable  $x_{i_n}$  to the  $j$ -th output of flowgraph.

---

<sup>5</sup>Here the matrices of the type  $A, B, C$  or  $D$  are thought of as relations.

This equivalent form of the condition  $w \in F_{ij}$  coincides to the intuitive notion of *successful computation sequences* in  $F$  from the  $i$ -th input to the  $j$ -th output. *This show that  $\|F\|$  represent the (step-by-step) input-output behaviour of the flowgraph  $F$ .*

In the particular case of one-input or one-input/one-output variables the conditions may be written in a simpler form. For the first case, if we have only variables with one input and  $F = [(l_p \oplus x_1 \oplus \dots \oplus x_k) \cdot f] \uparrow^k: p \rightarrow q$ , then

$$w \in F_{ij}$$

(where  $F_{ij}$  is the component of  $\|F\|$ ) if and only if

1.  $w = \lambda$  and  $(i, j) \in f$  or
2.  $w = \langle x_{i_1}, s_1 \rangle \dots \langle x_{i_n}, s_n \rangle$  such that  $i_l \in [k]$  and  $s_l \in [o(x_{i_l})]$ , for  $l \in [n]$  and
  - (a)  $(i, q + i_1) \in f$ ;
  - (b)  $(p + o(x_1 \oplus \dots \oplus x_{i_{l-1}}) + s_1, q + i_2) \in f, \dots,$   
 $(p + o(x_1 \oplus \dots \oplus x_{i_{n-1}}) + s_{n-1}, q + i_n) \in f$ ;
  - (c)  $(p + o(x_1 \oplus \dots \oplus x_{i_{n-1}}) + s_n, j) \in f$ .

For the second case, if we have only variables with one input and one output and  $F = [(l_p \oplus x_1 \oplus \dots \oplus x_k) \cdot f] \uparrow^k: p \rightarrow q$ , then

$$w \in F_{ij}$$

(where  $F_{ij}$  is the component of  $\|F\|$ ) if and only if

1.  $w = \lambda$  and  $(i, j) \in f$  or
2.  $w = x_{i_1}x_{i_2} \dots x_{i_n}$  such that  $i_l \in [k]$  for all  $l \in [n]$  and
  - (a)  $(i, q + i_1) \in f$ ;
  - (b)  $(p + i_1, q + i_2) \in f, \dots, (p + i_{n-1}, q + i_n) \in f$ ;
  - (c)  $(p + i_n, j) \in f$ .

### 11.3.3 Reduction of semideterministic flowgraphs to deterministic ones

After all these preliminaries we may built up the deterministic flowgraph associated with a given semideterministic one. We start with a set of variables

$$V = \{z_1, \dots, z_r\} \subseteq X(1, 1)$$

that is linearly ordered, say

$$z_1 \prec z_2 \prec \dots \prec z_r$$

Let us consider a new set of variables

$$V_o \text{ consisting of a new variable } \bar{z}_i \in V_o(1, 1 + r) \text{ for every } z_i \in V \subseteq X(1, 1).$$

Let

$$F = [(l_1 \oplus x_1 \oplus \dots \oplus x_k) f] \uparrow^k \in \text{NF}\ell[X, \mathbb{R}\text{el}](1, 1)$$

be a semi-deterministic flowgraph and suppose  $V$  contains all the variables  $x_1, \dots, x_k$ . Starting with the relation  $f \in \mathbb{R}\text{el}(1+k, 1+k)$  we consider the partial function  $\bar{f} \in \mathbb{P}\text{fn}((1+k) \times (1+r), 1+k)$  defined by the tupling

$$\bar{f} = \langle \bar{f}_1, \bar{f}_2, \dots, \bar{f}_{1+k} \rangle$$

where for  $i \in [1+k]$  the partial function  $\bar{f}_i \in \mathbb{P}\text{fn}(1+r, 1+k)$  is defined as follows:

•

$$\bar{f}_i(1) = \text{if } (i, 1) \in f \text{ then } 1 \text{ else undefined}$$

• for  $i \in [r]$ ,

$$\bar{f}_i(1+j) = \text{if } (i, 1+l) \in f \ \& \ x_l = z_j \text{ then } 1+l \text{ else undefined}$$

Since the flowgraph  $F$  is semi-deterministic, for every  $i \in [1+k]$  and  $j \in [r]$  there exists at most one  $l$  such that  $(i, 1+l) \in f \ \& \ x_l = z_j$ , hence  $\bar{f}_i$  is a (partial) function, indeed.

Write  $f$  as a tupling

$$f = \langle f_1, f_2, \dots, f_{1+k} \rangle \quad \text{with} \quad f_i \in \mathbb{R}\text{el}(1, 1+k)$$

It follows that

$$\wedge_{1+r} \cdot \bar{f}_i = f_i$$

(Indeed, in the definition of  $f_i$  only the pairs  $(i, 1+l) \in f$  occur and all these pairs occur at least once in the definition of  $\bar{f}_i$ , for  $x_1, \dots, x_k \in V$ .) Consequently,

$$f = (\wedge_{1+r} \oplus \wedge_{1+r} \oplus \dots \oplus \wedge_{1+r}) \cdot \bar{f}$$

This implies,

$$\begin{aligned} F &= [(l_1 \oplus x_1 \oplus \dots \oplus x_k) \cdot f] \uparrow^k \\ &= [(l_1 \oplus x_1 \oplus \dots \oplus x_k) \cdot (\wedge_{1+r} \oplus \wedge_{1+r} \oplus \dots \oplus \wedge_{1+r}) \cdot \bar{f}] \uparrow^k \\ &= \wedge_{1+r} \cdot [(l_{1+r} \oplus x_1 \cdot \wedge_{1+r} \oplus \dots \oplus x_k \cdot \wedge_{1+r}) \cdot \bar{f}] \uparrow^k \end{aligned}$$

Define  $D_V(F) \in \text{NF}\ell[V_o, \mathbb{P}\text{fn}](1+r, 1)$  as

$$D_V(F) = [(l_{1+r} \oplus \bar{x}_1 \oplus \dots \oplus \bar{x}_k) \cdot \bar{f}] \uparrow^k$$

where for  $i \in [k]$ ,

$$\bar{x}_i = \bar{z}_{k_i} \in V_o(1, 1+r) \quad \text{whenever} \quad x_i = z_{k_i} \in V$$

Now, let us look at the successful computation sequences of  $D_V(F)$ . Using the above observation it follows that a successful computation sequence in  $D_V(F)$  of a positive length from the  $j$ -th input ( $j \in [1+r]$ ) to the 1-st output has the following form:

$$w = \langle \bar{x}_{i_1}, s_1 \rangle \langle \bar{x}_{i_2}, s_2 \rangle \dots \langle \bar{x}_{i_n}, s_n \rangle$$

where  $n \geq 1, i_l \in [k]$  and  $s_l \in [o(x_{i_l})]$ , for  $l \in [n]$  and

- $(j, 1 + i_1) \in \bar{f}$ ;
- $(1+r+(i_1-1) \times (1+r)+s_1, 1+i_2) \in \bar{f}, \dots, (1+r+(i_{n-1}-1) \times (1+r)+s_{n-1}, 1+i_n) \in \bar{f}$ ;
- $(1+r+(i_n-1) \times (1+r)+s_n, 1) \in \bar{f}$ .

From the definition of  $\bar{f}$  it follows that

- $(1, 1 + i_1) \in f \ \& \ x_{i_1} = z_{j-1}$ ;
- $(1 + i_1, 1 + i_2) \in f \ \& \ x_{i_2} = z_{s_1-1}, \dots, (1 + i_{n-1}, 1 + i_n) \in f \ \& \ x_{i_n} = z_{s_{n-1}-1}$ ;
- $(1 + i_n, 1) \in f \ \& \ s_n = 1$ .

Define

$$\psi_1(w) = x_{i_1}x_{i_2} \dots x_{i_n}$$

From the last version of the definition of successful computation sequences it follows that we get a sequence in  $F$ , i.e.  $\psi_1(w) \in \|F\|$ . Moreover,

- $j - 1 =$  “the order number of the variable  $x_{i_1}$  in  $V$ ”;
- for every  $l \in [n - 1]$ ,  $s_l - 1 =$  “the order number of the variable  $x_{i_{l+1}}$  in  $V$ ”; and
- $s_n = 1$ .

Conversely, if  $w = x_{i_1}x_{i_2} \dots x_{i_n}$  with  $n \geq 1$  is a sequence in  $\|F\|$ , and if we take the numbers  $j, s_1, s_2, \dots, s_n$  defined by the sequence  $w$  and the above conditions, then we get a successful computation sequence from  $j$  to 1 in  $D_V(F)$ , i.e.

$$\psi_2(w) := \langle \bar{x}_{i_1}, s_1 \rangle \langle \bar{x}_{i_2}, s_2 \rangle \dots \langle \bar{x}_{i_n}, s_n \rangle$$

It is obvious that the application  $\psi_1$  is the inverse of  $\psi_2$ . Let us distribute the computation sequences in  $\|F\|$  into  $1 + r$  disjoint sets  $M_1, M_2, \dots, M_{1+r}$  as follows:

- $M_1 = \{ \text{the sequences of length zero} \}$ ;
- $M_2 = \{ \text{the sequences beginning with } z_1 \}$ ;
- $\vdots$ ;
- $M_{1+r} = \{ \text{the sequences beginning with } z_r \}$ .

All the above show that

$$\|D_V(F)\| = \begin{pmatrix} \psi_2(M_1) \\ \psi_2(M_2) \\ \vdots \\ \psi_2(M_{1+r}) \end{pmatrix}$$

From this the following proposition follows:

**Proposition 11.16** *Let  $F', F'' \in \text{NF}\ell[X, \text{Rel}](1, 1)$  be two semideterministic flowgraphs such that*

$$\|F'\| = \|F''\|$$

*and suppose  $V$  is a finite, linearly ordered set containing all the variables that occur in  $F'$  or  $F''$ . Then*

$$\|D_V(F')\| = \|D_V(F'')\| \quad \square$$

The original flowgraph  $F$  may be obtained from  $D_V(F)$  by substituting  $z_1 \cdot \wedge_{1+r}$  for  $\bar{z}_l$ ,  $\forall l \in [r]$ ; this substitution is denoted by  $[\bar{z}_1/z_1 \cdot \wedge_{1+r}; \dots; \bar{z}_r/z_r \cdot \wedge_{1+r}]$ . To be precise,

$$F = \wedge_{1+r} \cdot D_V(F)[\bar{z}_1/z_1 \cdot \wedge_{1+r}; \dots; \bar{z}_r/z_r \cdot \wedge_{1+r}]$$

**Lemma 11.17** *If  $D_V(F') \xleftarrow{u} D_V(F'')$ , then  $F' \xleftarrow{u} F''$ .*

**Proof:** Let

$$F' = [(l_1 \oplus x'_1 \oplus \dots \oplus x'_{k'}) f'] \uparrow^{k'} \quad \text{and} \quad F'' = [(l_1 \oplus x''_1 \oplus \dots \oplus x''_{k''}) f''] \uparrow^{k''}$$

be two semi-deterministic flowgraphs and let

$$D_V(F') = [(l_1 \oplus \bar{x}'_1 \oplus \dots \oplus \bar{x}'_{k'}) \bar{f}'] \uparrow^{k'} \quad \text{and} \quad D_V(F'') = [(l_1 \oplus \bar{x}''_1 \oplus \dots \oplus \bar{x}''_{k''}) \bar{f}''] \uparrow^{k''}$$

be their deterministic versions obtained using the above procedure. The given simulation shows that

1.  $(i, j) \in u \Rightarrow \bar{x}'_i = \bar{x}''_j$  and
2.  $\bar{f}' \cdot (l_1 \oplus u) = (l_{1+r} \oplus o(u)) \cdot \bar{f}''$ .

Since

$$\begin{aligned} f' \cdot (l_1 \oplus u) &= (\wedge_{1+r} \oplus \wedge_{1+r} \oplus \dots \oplus \wedge_{1+r}) \cdot \bar{f}' \cdot (l_1 \oplus u) \\ &= [\wedge_{1+r} \oplus (\wedge_{1+r} \oplus \dots \oplus \wedge_{1+r}) \cdot o(u)] \cdot \bar{f}'' \\ &= [\wedge_{1+r} \oplus u \cdot (\wedge_{1+r} \oplus \dots \oplus \wedge_{1+r})] \cdot \bar{f}'' \\ &= (l_1 + u) \cdot f'' \end{aligned}$$

and

$$(i, j) \in u \Rightarrow x'_i = x''_j$$

we get

$$F' \xrightarrow{u} F'' \quad \square$$



### 11.3.4 Completeness theorem

**Theorem 11.18** *Let  $F', F'' \in \text{NF}\ell[X, \text{Rel}](p, q)$  be two n.f. flownomial expressions. Then*

*the flowgraphs associated to  $F$  and  $F'$  have the same input-output step-by-step behaviour (i.e. for every  $i \in [p], j \in [q]$  both flowgraphs have the same set of successful computation sequences starting from the  $i$ -th input and ending to the  $j$ -th output)*

*if and only if*

$$F' \stackrel{d\delta}{\iff} F''$$

**Proof:** Since the functoriality axiom holds in a matrix theory of languages, it follows that two  $d\delta$ -equivalent flowgraphs have the same input-output behaviour.

For the converse implication, as we have mentioned in the beginning of this subsection, we may restrict our proof to the case  $p = q = 1$ . We know that

$$\|F'\| = \|F''\|$$

As in Lemma 11.15 we construct the associated semideterministic flowgraphs  $SD(F')$  and  $SD(F'')$ . But  $F'$  and  $SD(F')$  are  $d\delta$ -similar (Lemma 11.15), hence they have the same behaviour  $\|F'\| = \|SD(F')\|$ . Analogously,  $\|F''\| = \|SD(F'')\|$ , so that

$$\|SD(F')\| = \|SD(F'')\|$$

For an appropriate  $V$  we construct the deterministic flowgraphs  $D_V(SD(F'))$  and  $D_V(SD(F''))$ . By Proposition 11.16 these deterministic flowgraphs have the same input-output behaviour. By Theorem 10.14 it follows that

$$D_V(SD(F')) \stackrel{b\delta}{\iff} D_V(SD(F''))$$

and by Lemma 11.17 we get

$$SD(F') \stackrel{b\delta}{\iff} SD(F'')$$

Consequently,

$$F' \xrightarrow{d\delta} SD(F') \stackrel{b\delta}{\iff} SD(F'') \xleftarrow{d\delta} F''$$

hence

$$F' \stackrel{d\delta}{\iff} F'' \quad \square$$

**Corollary 11.19** *The following conditions are equivalent for two flownomial expressions  $E$  and  $E'$  in  $\mathbb{F}\ell_{EXP}[X, \text{Rel}]$ :*

1.  $E \sim_{d\delta} E'$
2.  $\text{nf}(E) \stackrel{d\delta}{\iff} \text{nf}(E')$
3. *The flowgraphs associated to  $E$  and  $E'$  have the same input-output step-by-step behaviour.*

## 11.4 Universality of $d\delta$ -flownomials

The definitions of the  $d\delta$ -Flow-Calculus and of the  $d\delta$ -flownomials appear as particular instances of the general definitions given before (Definition 8.12). Theorems 5.28, 11.13 and Corollary 11.12 give the following result.

**Theorem 11.20** (*universality of  $d\delta$ -flownomials*)

*If  $T$  is a zero-sum-free and uniform divisible  $d\delta$ -flow, then the statement obtained from that one of Theorem 8.20 by replacing everywhere  $a\delta$  by  $d\delta$  is valid.  $\square$*

Since  $\mathbb{R}el$  is an initial  $d\delta$ -flow in the category of  $d\delta$ -flows, the following corollary may be obtained.

**Corollary 11.21**  $\mathbb{F}l_{a\delta}[X, T]$  is the  $d\delta$ -flow freely generated by  $X$ .  $\square$

## 11.5 Short comments and references

This chapter is basically Chapter E of [Ste91].

Except for the completeness part, the axiomatisation result of this chapter is from [Ste87b]. There it is inserted the conjecture that simulation via relations capture the input-output behaviour, as well.

The key point towards the completeness result is due to [Koz91, BIEs92]. In this papers it is shown that the standard powerset construction of the deterministic automaton associated to a nondeterministic one may be modelled by simulation via relations. Some more transformations were necessary since from the flowchart scheme point of view a deterministic automaton is still a nondeterministic flowchart.

This axiomatisation is closed related to that of regular algebras. An equational axiomatisation is presented in [BIEs92] using Esik's technique of replacing the enzymatic rule by an equation. A stronger result is presented in [Kro91] where two conjectures of Conway are proved using a different technique.

# Bibliography

- [ArM80] M.A. Arbib and E.G. Manes. Partially additive categories and flow diagram semantics. *Journal of Algebra*, 62:203–227, 1980.
- [BaW90] J. Baeten and W. Weijland. *Process algebra*. Cambridge University Press, 1990.
- [Bai76] E.S. Bainbridge. Feedback and generalized logic. *Information and Control*, 31:75–96, 1976.
- [Bar87a] M. Bartha. A finite axiomatization of flowchart schemes. *Acta Cybernetica*, 8:203–217, 1987.
- [BenT89] D.B. Benson and J. Tiuryn. Fixed points in free process algebra I. *Theoretical Computer Science*, 63:275–294, 1989.
- [BeK84] J.A. Bergstra and J.W. Klop. Process algebra for synchronous communication. *Information and Control*, 60:109–137, 1984.
- [BeS93] J.A. Bergstra and Gh. Stănescu. Translations between flowchart schemes and process graphs. In: *Proceedings FCT'93*, pages 153–162. LNCS 710, Springer-Verlag, 1993.
- [BeS94a] J.A. Bergstra and Gh. Stănescu. Bisimulation is two-way simulation. Technical Report PRG-9402, Programming Research Group, University of Amsterdam, 1994. To appear in *Information Processing Letters*.
- [BlEW80a] S.L. Bloom, C.C. Elgot, and J.B. Wright. Solutions of the iteration equation and extensions of the scalar iteration operation. *SIAM Journal of Computing*, 9:26–45, 1980.
- [BlEW80b] S.L. Bloom, C.C. Elgot, and J.B. Wright. Vector iteration in pointed algebraic theories. *SIAM Journal of Computing*, 9:525–540, 1980.
- [BlEs85] S.L. Bloom and Z. Esik. Axiomatizing schemes and their behaviour. *Journal of Computer and System Sciences*, 31:375–393, 1985.
- [BlEs92] S.L. Bloom and Z. Esik. Equational axioms for regular sets. *Mathematical Structures in computer Science*, 2, 1992.
- [BlEs93a] S.L. Bloom and Z. Esik. *Iteration theories: the equational logic of iterative processes*. Springer-Verlag, 1993.

- [BIES91] S.L. Bloom, Z. Esik, and Gh. Stefănescu. *Notes on the equational theories of relations*. Technical Report 9113, Stevens Institute of Technology, Hoboken, N.J., 1991. To appear in *Algebra Universalis*.
- [BIET93] S.L. Bloom, Z. Esik, and D. Taubner. Iteration theory of synchronization trees. *Information and Computation*, 102:1–55, 1993.
- [Bro92a] M. Broy. Functional specification of time sensitive communicating systems. In M. Broy, editor, *Proceedings Summer School on Programming and Mathematical Methods, Marktoberdorf, 1990*, Springer-Verlag, 1992.
- [Bro92b] M. Broy. Compositional refinement of reactive systems. Technical Report 89, System Research Center, DEC, 1992.
- [BrS94] M. Broy and Gh. Stefanescu. Algebra of stream processing functions. Draft, 1994.
- [Brz64] J.A. Brzozowski. Derivatives of regular expressions. *Journal of the Association for Computing Machinery*, 11:481–494, 1964.
- [CaS88a] V.E. Căzănescu and Gh. Stefănescu. A formal representation of flowchart schemes I & II. *Analele Universității București, Matematică - Informatică*, 37:33–51, 1988 and *Studii si Cercetări Metematice*, 41:151–167, 1989.
- [CaS88b] V.E. Căzănescu and Gh. Stefănescu. *Feedback, iteration and repetition*. Preprint 42, The National Institute for Scientific and Technical Creation, Bucharest, 1988. To appear in a volum, World Scientific, 1995.
- [CaS88c] V.E. Căzănescu and Gh. Stefănescu. Bi-Flow-Calculus. Unpublished manuscript, 1988.
- [CaS90a] V.E. Căzănescu and Gh. Stefănescu. Towards a new algebraic foundation of flowchart scheme theory. *Fundamenta Informaticae*, 13:171–210, 1990.
- [CaS90b] V.E. Căzănescu and Gh. Stefănescu. A note on axiomatizing flowchart schemes. *Acta Cybernetica*, 9:349–359, 1990.
- [CaS91] V.E. Căzănescu and Gh. Stefănescu. Classes of finite relations as initial abstract data types I & II. *Discrete Mathematics*, 90:233–265, 1991 and 126, 1994.
- [CaS92] V.E. Căzănescu and Gh. Stefănescu. A general result of abstarct flowchart schemes with applications to the study of accessibility, reduction and minimization. *Theoretical Computer Science*, 99:1–63, 1992.
- [CaU82] V.E. Căzănescu and C. Ungureanu. Again on advice on structuring compilers and proving them correct. Preprint, The National Institute for Scientific and Technical Creation, Bucharest, 1982.
- [Con71] J. Conway. *Regular Algebra and Finite Machines*. Chapman and Hall, London, 1971.

- [Cou83] B. Courcelle. Fundamental properties of infinite trees. *Theoretical Computer Science*, 25:95–169, 1983.
- [Elg75] C.C. Elgot. Manadic computation and iterative algebraic theories. In *Proceedings Logic Colloquium '73*, pages 175–230, North-Holland, 1975. Studies in Logic and the Foundations of Mathematics, Volume 80.
- [Elg76a] C.C. Elgot. Structured programming with and without GO TO statements. *IEEE Transactions on Software Engineering*, SE-2:41–53, 1976.
- [Elg76b] C.C. Elgot. Matricial theories. *Journal of Algebra*, 42:391–421, 1976.
- [Elg77] C.C. Elgot. Some geometrical categories associated with flowchart schemes. In *Proceedings FCT'77*, pages 256–259, Springer–Verlag LNCS, 1977.
- [EIBT78] C.C. Elgot, S.L. Bloom, and R. Tindell. On the algebraic structure of rooted trees. *Journal of Computer and System Sciences*, 16:362–399, 1978.
- [ELS82] C.C. Elgot and J.C. Shepherdson. An equational axiomatization of the algebra of reducible flowchart schemes. In: *Selected papers, C.C. Elgot*, Ed. S.L. Bloom, Springer–Verlag, 1982.
- [Esi80] Z. Esik. Identities in iterative and rational algebraic theories. *Computational Linguistic and Computational Languages*, 7:183–207, 1980.
- [Esi90] Z. Esik. A note on the axiomatisation of iteration theories. *Acta Cybernetica*, Vol.9, 1990.
- [Gin79] S. Ginali. Regular trees and free iterative theories. *Journal of Computer and System Sciences*, 18:228–242, 1979.
- [Gir87] J.-Y. Girard. Linear logic. *Theoretical Computer Science*, 50, 1987.
- [Gog74] J.A. Goguen. On homomorphism, correctness, termination, unfoldments and equivalence of flow diagram programs. *Journal of Computer and System Sciences*, 8:333–365, 1974.
- [GTWR77] J.A. Goguen, J.W. Thatcher, E.G. Wagner, and J.B. Wright. Initial algebra semantics and continuous algebras. *Journal of the Association for Computing Machinery*, 24:68–95, 1977.
- [Gre75] S. Greibach. *Theory of program structures: schemes, semantics, verification*. Springer–Verlag, 1975.
- [Hot65] H. Hotz. ...
- [Kle56] S.C. Kleene. Representation of events in nerve nets and finite automata. In: C.E. Shannon and J. McCarthy, editors, *Automata Studies*, Princeton University Press, 1956. Annals of Mathematical Studies, Volume 34.
- [Koz91] D. Kozen. A completeness theorem for Kleene algebras and the algebra of regular events. In *Proceedings LICS'91*, pages 214–225, IEEE Press, 1991.

- [Kro91] D. Krob. Complete systems of B-rational identities. *Theoretical Computer Science*, 89:207–343, 1991.
- [Laf92] Y. Lafont. Penrose diagrams and 2-dimensional rewriting. In *Proceedings LMS Symposium on Application of Categories in Computer Science*, 1992.
- [Law63] F.W. Lawvere. Functorial semantics of algebraic theories. *Proceedings of the National Academy of Sciences, U.S.A.*, 50:869–872, 1963.
- [MacL71] S. MacLane. *Categories for the working mathematician*. Springer–Verlag, 1971.
- [MaA86] E.G. Manes and M.A. Arbib. *Algebraic approaches to program semantics*. Springer–Verlag, 1986.
- [Man92] E.G. Manes. *Predicate transformer semantics*. Cambridge University Press, 1992.
- [Mann74] Z. Manna. *Mathematical theory of computation*. McGraw-Hill, New York, 1974.
- [MeM90] J. Meseguer and U. Montanari. Petri nets are monoids. *Information and Computation*, 88:105–155, 1990.
- [Mil79] R. Milner. Flowgraphs and flow algebra. *Journal of the Association for Computing Machinery*, 26:794–818, 1979.
- [Mil80] R. Milner. *A calculus of communicating systems*. Springer–Verlag, 1980.
- [Mil89] R. Milner. *Communication and concurrency*. Prentice Hall International, 1989.
- [Mol88] P. Molitor. Free net algebras in VLSI-Theory. *Fundamenta Informaticae*, 11:117–142, 1988.
- [Park80] D. Park. Concurrency and automata on infinite sequences. In *Proceedings 5th GI Conference*, 167–183. LNCS 104, Springer Verlag, 1981.
- [Parr87] J. Parrow. *Synchronization flow algebra*. Report LFCS- 87-35, Laboratory for the Foundation of Computer Science, University of Edinburgh, 1987.
- [Sal66] A. Salomaa. Two complete axiom systems for the algebra of regular events. *Journal of the Association for Computing Machinery*, 13:158–169, 1966.
- [Sch83a] H. Schmeck. Algebraic characterizations of reducible flowcharts. *Journal of Computer and System Sciences*, 27:165–199, 1983.
- [ScS93] G. Schmidt and T. Strohlein. *Relations and graphs*. Springer–Verlag, 1993.
- [Sco71] D. Scott. The lattice of flow diagrams. In *Proceedings of the Symposium on Semantics of Algorithmic Languages* pages 311–366, LNMath. 188., Springer–Verlag, 1971.
- [Ste87a] Gh. Stefănescu. On flowchart theories I: The deterministic case. *Journal of Computer and System Sciences*, 35:163–191, 1987.

- [Ste87b] Gh. Stefănescu. On flowchart theories II: The nondeterministic case. *Theoretical Computer Science*, 52:307–340, 1987.
- [Ste86] Gh. Stefănescu. An algebraic theory of flowchart schemes. In *Proceedings CAAP'86*, pages 60–73, LNCS 214, Springer–Verlag, 1986.
- [Ste86/90] Gh. Stefănescu. Feedback theories (a calculus for isomorphism classes of flowchart schemes). *Revue Roumaine de Mathématiques Pures et Appliquée*, 35:73–79, 1990. Early distributed as: *Preprint Series in Mathematics*, The National Institute for Scientific and Technical Creation, Bucharest, No. 24/April 1986.
- [Ste91] Gh. Stefănescu. *Determinism and nondeterminism in program scheme theory: algebraic aspects*. PhD thesis, 192+iv pages. University of Bucharest, 1991. [Romanian]
- [Sza80] M.E. Szabo. *Algebra of proofs*. North-Holland, 1980.
- [TaG87] A. Tarski and S. Givant. *A formalization of set theory without variables*. Amer. Math. Soc., 1987.
- [WTWG76] J.B. Wright, J.W. Thatcher, E.G. Wagner, and J.A. Goguen. Rational algebraic theories and fixed point solutions. In *Proceedings FOCS'76*, pages 147–158, IEEE Press, 1976.
- [Yan58] Yu.I. Yanov. On logical schemata of algorithms. In V.E. Liapunoff, editor, *Problems of Cybernetics, Vol. 1*, Fitmatgiz, 1958. [Russian]

# Chapter 12

## Appendix: Two presentations for $a\alpha$ -flow

The aim of this appendix is to prove that the notions of  $a\alpha$ -flow and LR-flow over  $\mathbb{Bi}$  coincide. One implication is supported by the following lemma.

**Lemma 12.1** ( $a\alpha$ -flow  $\Rightarrow$  LR-flow over  $\mathbb{Bi}$ )

Suppose  $T = (\{T(m, n)\}_{m, n \in M}, \oplus, \cdot, \uparrow, \downarrow_m, {}^m X^n)$  is an  $a\alpha$ -flow. Then  $(T, \oplus, \cdot_L, \cdot_R, \uparrow, \downarrow_m)$  is a LR-flow over  $\mathbb{Bi}$ , where

$$\begin{aligned} f \cdot_{R(n_1, \dots, n_k)} \phi &= f \cdot (\phi(1)_{n_1} \dots \phi(k)_{n_k}) \quad \text{and} \\ \phi \cdot_{L(m_1, \dots, m_k)} f &= (\psi(1)_{m_{\psi(1)}} \dots \psi(k)_{m_{\psi(k)}}) \cdot f \end{aligned}$$

(Recall the notation  $(\phi(1)_{c_1} \dots \phi(k)_{c_k})$ : Let  $S \supset \{s_1, \dots, s_k\}$  and  $\bar{\phi} \in \mathbb{Bi}_S(s_1 \oplus \dots \oplus s_k, s_{\phi^{-1}(1)} \oplus \dots \oplus s_{\phi^{-1}(k)})$  be a multi-sorted bijection induced by  $\phi$ . Let  $H : \mathbb{Bi}_S \rightarrow T$  be the unique morphism of  $a\alpha$ -flows (provided by Theorem B.2) which extends the function  $h : S \rightarrow M$  that maps  $s_i$  to  $c_i$ , for every  $i \in [k]$ . Then  $(\phi(1)_{c_1} \dots \phi(k)_{c_k}) = H(\bar{\phi})$ .  $\square$

**Proof:** Since  $\cdot_R$  and  $\cdot_L$  are particular instances of the  $\cdot$  composition, all the LR-flow axioms in Table 5.1 are particular instances of the corresponding  $a\alpha$ -flow axioms in Table 4.1.

The validity of the refinement rule R-REFINE follows from the unique-extension-property in Theorem 2.5 as follows:

- For the left-hand-side term, let us start with  $k$  different sorts  $s_1, \dots, s_i, \dots, s_k$  in order to get the meaning of  $\phi$  in  $t$  according to the assignment  $n_1, \dots, n_i^1, \dots, n_i^l, \dots, n_k$  for  $s_1, \dots, s_i, \dots, s_k$ .
- For the right-hand-side term, starting similarly, first we get the meaning  $\phi'$  of  $\phi$  in a  $\mathbb{Rel}_{\{s_1, \dots, s_k, t_1^1, \dots, t_i^l\}}$  according to the valuation of  $s_i, \dots, s_i, \dots, s_k$  to  $s_1, \dots, t_i^1 \oplus \dots \oplus t_i^l, \dots, s_k$ . Then we evaluate  $\phi'$  in  $T$  according to the assignment  $n_1, \dots, n_i^1, \dots, n_i^l, \dots, n_k$  for  $s_1, \dots, t_1, \dots, t_l, \dots, s_k$ .

Finally, by Theorem 2.5 in both cases we get the same abstract bijection in  $T$  since both evaluations agree on the generators  $s_1, \dots, s_k$ .

Similarly for L-REFINE.  $\square$



**Lemma 12.2** (*LR-flow over Bi  $\Rightarrow$   $a\alpha$ -flow*)

Let  $(M, \oplus, 0)$  be a monoid. Suppose  $(\{T(m, n)\}_{m, n \in M}, \oplus, \cdot_L, \cdot_R, \uparrow, \mathbb{1}_m)$  is a LR-flow over Bi and define:

(DEF) for  $f : m \rightarrow n$  and  $g : n \rightarrow p$

$$f \cdot g = [(f \oplus g) \cdot_{R(n,p)} \mathbb{1}^{\mathbb{X}^1}] \uparrow^n$$

and

$${}^p \mathbb{X}^q = \mathbb{1}_{p \oplus q} \cdot_{R(p,q)} \mathbb{1}^{\mathbb{X}^1}$$

Then  $T = (\{T(m, n)\}_{m, n \in M}, \oplus, \cdot, \uparrow, \mathbb{1}_m, {}^m \mathbb{X}^n)$  is an  $a\alpha$ -flow.

**Proof:** For the beginning, let us note that

$$(DEF') \quad f \cdot g = [(21) \cdot_{L(n,m)} (g \oplus f)] \uparrow^n \quad \text{for } f : m \rightarrow n \text{ and } g : n \rightarrow p$$

holds in  $T$ . Indeed,

$$\begin{aligned} [(21) \cdot_{L(n,m)} (g \oplus f)] \uparrow^n &= [(21) \cdot_{L(n,m)} [(21) \cdot_{L(m,n)} (f \oplus g)] \cdot_{R(n,p)} (21)] \uparrow^n && \text{by LR6} \\ &= [(f \oplus g) \cdot_{R(n,p)} (21)] \uparrow^n && \text{by LR3, LR4a} \\ &= f \cdot g && \text{by DEF} \end{aligned}$$

We denote by LR7z' the rule obtained by a repetitive application of rule LR7z with  $z \in \{a, b, c, d\}$ ; for example LR7a' is

$$\phi \cdot_{L(P)} f \uparrow^{p_1 \oplus \dots \oplus p_r} = [(\phi \oplus \mathbb{1}_r) \cdot_{L(P, p_1, \dots, p_r)} f] \uparrow^{p_1 \oplus \dots \oplus p_r}.$$

LR8 coincides to rule R8. Moreover, the identity

$$\begin{aligned} \text{R8}' \quad f \uparrow^p \oplus g &= [(132) \cdot_{L(m,p,m')} (f \oplus g) \cdot_{R(n,p,n')} (132)] \uparrow^p \\ &\text{for } f : m \oplus p \rightarrow n \oplus p, \quad g : m' \rightarrow n' \end{aligned}$$

holds in  $T$ . Indeed,

$$\begin{aligned} f \uparrow^p \oplus g &= (21) \cdot_{L(m',m)} (g \oplus f \uparrow^p) \cdot_{R(n',n)} (21) && \text{by LR6} \\ &= (21) \cdot_{L(m',m)} (g \oplus f) \uparrow^p \cdot_{R(n',n)} (21) && \text{by R8} \\ &= [(213) \cdot_{L(m',m,p)} (g \oplus f) \cdot_{R(n',n,p)} (213)] \uparrow^p && \text{LR7a, LR7b} \\ &= [(213) \cdot_{L(m',m,p)} [(21) \cdot_{L(m \oplus p, m')} (f \oplus g) \cdot_{R(n \oplus p, n')} (21)] \cdot_{R(n',n,p)} (213)] \uparrow^p && \text{by LR6} \\ &= [(213) \cdot_{L(m',m,p)} [(312) \cdot_{L(m,p,m')} (f \oplus g) \cdot_{R(n,p,n')} (231)] \cdot_{R(n',n,p)} (213)] \uparrow^p && \text{REFINE} \\ &= (132) \cdot_{L(m,p,m')} (f \oplus g) \cdot_{R(n,p,n')} (132)] \uparrow^p && \text{by LR3} \end{aligned}$$

Let  $P :: p = p_1 \oplus p \dots \oplus p_k$ ,  $Q :: q = q_1 \oplus \dots \oplus q_l$  and  $f : m \oplus p \oplus s \oplus t \oplus q \rightarrow n \oplus p \oplus s \oplus t \oplus q$ . The LR9 implies

$$[(f \uparrow^q) \cdot_{R(n,P,t,s)} (\mathbb{1}_1 \oplus \mathbb{1}_k \oplus \mathbb{1}^{\mathbb{X}^1})] \uparrow^{s \oplus t \oplus p} = [(\mathbb{1}_1 \oplus \mathbb{1}_k \oplus \mathbb{1}^{\mathbb{X}^1}) \cdot_{L(m,P,s,t)} (f \uparrow^q)] \uparrow^{t \oplus s \oplus p}$$

Using LR7a and LR7a in this equality we get

$$[f \cdot_{R(m,P,t,s,Q)} (\mathbb{1}_1 \oplus \mathbb{1}_k \oplus \mathbb{1}^{\mathbb{X}^1} \oplus \mathbb{1}_l)] \uparrow^{p \oplus s \oplus t \oplus q} = [(\mathbb{1}_1 \oplus \mathbb{1}_k \oplus \mathbb{1}^{\mathbb{X}^1} \oplus \mathbb{1}_l) \cdot_{L(m,P,s,t,Q)} f] \uparrow^{p \oplus t \oplus s \oplus q}$$

Since every morphism in Bi is a composite of morphisms of the type  $\mathbb{1}_p \oplus \mathbb{1}^{\mathbb{X}^1} \oplus \mathbb{1}_q$  it follows that

$$\text{LR9}' \quad [f \cdot_{R(n, \phi^{-1}(P))} (\mathbb{1}_1 \oplus \phi)] \uparrow^p = [(\mathbb{1}_1 \oplus \phi) \cdot_{L(m, P)} f] \uparrow^q$$

for  $f \in T(m \oplus p, n \oplus q)$ ,  $\phi \in \mathbb{B}i(k, k)$  and  $P :: p = p_1 \oplus \dots \oplus p_k$ ,  $q = p_{\phi(1)} \oplus \dots \oplus p_{\phi(k)}$ .

holds in a LR-flow over  $\mathbb{B}i$ .

The defined Composition extends the Left- and Right-Composition with morphisms in  $\mathbb{B}i$ . More precisely, a bijection  $\phi \in \mathbb{B}i(k, k)$  may be thought of as an element in  $T(m, n)$ , relative to a decomposition  $m = p_1 \oplus \dots \oplus p_k$  and  $n = p_{\phi^{-1}(1)} \oplus \dots \oplus p_{\phi^{-1}(k)}$ . Namely, it is  $\mathbb{1}_m \cdot_{R(p_1, \dots, p_k)} \phi$  (equal to  $\phi \cdot_{L(p_{\phi^{-1}(1)}, \dots, p_{\phi^{-1}(k)})} \mathbb{1}_n$ ). This observation follows from the identities

$$\begin{aligned} \text{RSC} \quad f \cdot_{R(n_1 \oplus \dots \oplus n_k)} \phi &= f \cdot (\mathbb{1}_n \cdot_{R(n_1 \oplus \dots \oplus n_k)} \phi) \\ \text{for } f \in T(m, n), n &= n_1 \oplus \dots \oplus n_k \text{ and } \phi \in \mathbb{B}i(k, k) \end{aligned}$$

$$\begin{aligned} \text{LSC} \quad \phi \cdot_{L(n_1, \dots, n_k)} f &= (\phi \cdot_{L(n_1, \dots, n_k)} \mathbb{1}_n) \cdot f \\ \text{for } \phi \in \mathbb{B}i(k, k), n &= n_1 \oplus \dots \oplus n_k \text{ and } f \in T(n, p) \end{aligned}$$

which are valid in  $T$ . Indeed, for RSC if  $P = (n_1, \dots, n_k)$  with  $n = n_1 \oplus \dots \oplus n_k$ ,  $p = n_{\phi^{-1}(1)} \oplus \dots \oplus n_{\phi^{-1}(k)}$  and  $\phi \in \mathbb{B}i(k, k)$ , then<sup>1</sup>

$$\begin{aligned} f \cdot (\mathbb{1}_n \cdot_{R(P)} \phi) &= [(f \oplus \mathbb{1}_n \cdot_{R(P)} \phi) \cdot_{R(n, p)} (21)] \uparrow^n && \text{by DEF} \\ &= [((f \oplus \mathbb{1}_n) \cdot_{R(n, P)} (\mathbb{1}_1 \oplus \phi)) \cdot_{R(n, \phi(P))} (2_1 \mathbb{1}_k)] \uparrow^n && \text{LR5a, REFINE} \\ &= ((f \oplus \mathbb{1}_n) \cdot_{R(n, P)} [(\mathbb{1}_1 \oplus \phi) \circ {}^1 \mathbb{X}^k]) \uparrow^n && \text{LR3} \\ &= ((f \oplus \mathbb{1}_n) \cdot_{R(P, P)} [(\mathbb{1}_k \oplus \phi) \circ {}^k \mathbb{X}^k]) \uparrow^{n_1 \oplus \dots \oplus n_k} && \text{REFINE} \\ &= f \cdot_{R(P)} [(\mathbb{1}_k \oplus \phi) \circ {}^k \mathbb{X}^k] \uparrow^k && \text{repeted LR7c} \\ &= f \cdot_{R(P)} \phi && \text{identity in } \mathbb{B}i \end{aligned}$$

and using (DEF') similarly one may prove LSC.

Now we check the validity of the axioms R1–R9 from the definition of an  $a\alpha$ -flow.

First, it is clear that R1 coincides with LR1 and R2 with LR2. For R3, suppose

$m \xrightarrow{f} n \xrightarrow{g} p \xrightarrow{h} q$ . Then

$$\begin{aligned} f \cdot (g \cdot h) &= [(f \oplus [(g \oplus h) \cdot_{R(p, q)} (21)] \uparrow^p) \cdot_{R(n, q)} (21)] \uparrow^n && \text{by DEF} \\ &= [(f \oplus (g \oplus h) \cdot_{R(p, q)} (21)) \uparrow^p \cdot_{R(n, q)} (21)] \uparrow^n && \text{by LR8} \\ &= [(f \cdot_{R(n)} (1) \oplus (g \oplus h) \cdot_{R(p, q)} (21)) \cdot_{R(n, q, p)} (213)] \uparrow^p \uparrow^n && \text{by LR4a, LR7b} \\ &= [(f \oplus g \oplus h) \cdot_{R(n, p, q)} (231)] \uparrow^{n \oplus p} \end{aligned}$$

and

$$\begin{aligned} (f \cdot g) \cdot h &= [([(f \oplus g) \cdot_{R(n, p)} (21)] \uparrow^n \oplus h) \cdot_{R(p, q)} (21)] \uparrow^p && \text{by DEF} \\ &= [([(132) \cdot_{L(m, n, p)} [(f \oplus g) \cdot_{R(n, p)} (21) \oplus h] \cdot_{R(p, n, q)} (132)] \uparrow^n \cdot_{R(p, q)} (21)] \uparrow^p && \text{by R8'} \\ &= [([(132) \cdot_{L(m, n, p)} (f \oplus g \oplus h) \cdot_{R(n, p, q)} [(213) \circ (132) \circ (213)]] \uparrow^n \uparrow^p && \text{LR5, LR7b, LR3} \\ &= [(f \oplus g \oplus h) \cdot_{R(m, n, p)} [(321) \circ (132)]] \uparrow^p \uparrow^n && \text{by LR9, LR3} \\ &= [(f \oplus g \oplus h) \cdot_{R(n, p, q)} (231)] \uparrow^{n \oplus p} \end{aligned}$$

---

<sup>1</sup>The compatibility condition in the fifth step clearly holds.

hence axiom R3 holds in  $T$ .

For R4, suppose  $f : m \rightarrow n$ . Then

$$\begin{aligned} \mathsf{l}_m \cdot f &= ((1) \cdot_{L(m)} \mathsf{l}_m) \cdot f \\ &= (1) \cdot_{L(m)} f && \text{by LSC} \\ &= f && \text{by LR4a} \end{aligned}$$

and similarly one may prove that

$$f \cdot \mathsf{l}_n = f$$

Hence R4 holds in  $T$ .

For R5 suppose  $m \xrightarrow{f} n \xrightarrow{g} p$  and  $m' \xrightarrow{f'} n' \xrightarrow{g'} p'$ . Then

$$\begin{aligned} (f \cdot g) \oplus (f' \cdot g') &= [(f \oplus g) \cdot_{R(n,p)} (21)] \uparrow^n \oplus [(f' \oplus g') \cdot_{R(n',p')} (21)] \uparrow^{n'} && \text{by DEF} \\ &= [((132) \cdot_{L(m,n,m' \oplus n')} [(f \oplus g) \cdot_{R(n,p)} (21) \oplus (f' \oplus g') \cdot_{R(n',p')} (21)]) \\ &\quad \cdot_{R(p,n,p' \oplus n')} (132)] \uparrow^n \uparrow^{n'} && \text{LR8, then R8'} \\ &= [((1342) \cdot_{L(m,n,m',n')} (f \oplus g \oplus f' \oplus g') \cdot_{R(n,p,n',p')} (2143)) \\ &\quad \cdot_{R(p,n,p',n')} (1423)] \uparrow^{n' \oplus n} && \text{LR5,REFINE} \\ &= [(1342) \cdot_{L(m,n,m',n')} (f \oplus g \oplus f' \oplus g') \cdot_{R(n,p,n',p')} (4132)] \uparrow^{n' \oplus n} && \text{by LR5, LR3} \\ &= [(1243) \cdot_{L(m,m',n,n')} (f \oplus f' \oplus g \oplus g') \cdot_{R(n,n',p,p')} (4312)] \uparrow^{n' \oplus n} && \text{LR6, LR5, LR3} \\ &= (f \oplus f' \oplus g \oplus g') \cdot_{R(n,n',p,p')} (3412) \uparrow^{n \oplus n'} && \text{by LR9', LR3} \\ &= (f \oplus f' \oplus g \oplus g') \cdot_{R(n \oplus n', p \oplus p')} (21) \uparrow^{n \oplus n'} && \text{by REFINE} \\ &= (f \oplus f') \cdot (g \oplus g') && \text{by DEF} \end{aligned}$$

Using LSC and RSC one easily prove that LR6 implies R6.

For R7, suppose  $f : m' \rightarrow m$ ,  $g : m \oplus p \rightarrow n \oplus p$  and  $h : n \rightarrow n'$ . Then,

$$\begin{aligned} g \uparrow^p \cdot h &= [(g \uparrow^p \oplus h) \cdot_{R(n,n')} (21)] \uparrow^n && \text{by DEF} \\ &= [((132) \cdot_{L(m,p,n)} (g \oplus h) \cdot_{R(n,p,n')} (132)] \uparrow^p \cdot_{R(n,n')} (21) \uparrow^n && \text{by R8'} \\ &= [(132) \cdot_{L(m,p,n)} (g \oplus h) \cdot_{R(n,p,n')} (231)] \uparrow^{n \oplus p} && \text{by LR7, LR3} \\ &= [(g \oplus h) \cdot_{R(n,p,n')} (321)] \uparrow^{p \oplus n} && \text{by LR9, LR3} \\ &= [(g \oplus h) \cdot_{R(n,p,n')} ((3412) \uparrow^1)] \uparrow^{p \oplus n} && \text{identity in IBi} \\ &= [(g \oplus h \oplus \mathsf{l}_p) \cdot_{R(n,p,n',p)} (3412)] \uparrow^{p \oplus n \oplus p} && \text{by LR7c} \\ &= [(g \oplus h \oplus \mathsf{l}_p) \cdot_{R(n \oplus p, n' \oplus p)} (21)] \uparrow^{n \oplus p \uparrow^p} && \text{by REFINE} \\ &= [g \cdot (h \oplus \mathsf{l}_p)] \uparrow^p && \text{by DEF} \end{aligned}$$

and dually, using (DEF') one may prove the other half of the identity R7, i.e.

$$f \cdot g \uparrow^p = [(f \oplus \mathsf{l}_p) \cdot g] \uparrow^p$$

Identity R8 coincides to LR8. For R9, suppose  $f : m \oplus p \rightarrow n \oplus q$  and  $g : q \rightarrow p$ . Then,

$$\begin{aligned}
& [f \cdot (l_n \oplus g)] \uparrow^p \\
&= [(f \oplus l_n \oplus g) \cdot_{R(n \oplus q, n \oplus p)} (21)] \uparrow^{n \oplus q} \uparrow^p && \text{by DEF} \\
&= [(f \oplus l_n \oplus g) \cdot_{R(n, q, n, p)} (3412)] \uparrow^{n \oplus q} \uparrow^p && \text{by REFINE} \\
&= [[(132) \cdot_{L(m \oplus p, q, n)} (f \oplus g \oplus l_n) \cdot_{R(n \oplus q, p, n)} (132)] \cdot_{R(n, q, n, p)} (3412)] \uparrow^{p \oplus n \oplus q} && \text{LR6, LR5} \\
&= [(132) \cdot_{L(m \oplus p, q, n)} (f \oplus g \oplus l_n) \cdot_{R(n, q, p, n)} (3421)] \uparrow^{p \oplus n \oplus q} && \text{LR3, REFINE} \\
&= [(f \oplus g \oplus l_n) \cdot_{R(n, q, p, n)} (4321)] \uparrow^{p \oplus q \oplus n} && \text{LR9', LR3} \\
&= [(f \oplus g) \cdot_{R(n, q, p)} ((4321) \uparrow^1)] \uparrow^{p \oplus q} && \text{by LR7a} \\
&= [(f \oplus g) \cdot_{R(n, q, p)} (132)] \uparrow^{p \oplus q}
\end{aligned}$$

and dual, using (DEF') one may prove that

$$[(l_m \oplus g) \cdot f] \uparrow^q = [(132) \cdot_{L(m, p, q)} (f \oplus g)] \uparrow^{q \oplus p}$$

From these two identities and LR9 it follows that R9 holds in  $T$ .

Finally, the axioms for constants C1–C5. C1 is already included in the definition of a LR-flow ober  $\mathbb{B}i$ . For C2 we have

$$\begin{aligned}
{}^0X^a &= l_{0 \oplus a} \cdot_{R(0, a)} {}^1\mathbb{X}^1 \\
&= l_a \cdot_{R(a)} \mathbb{1}_1 && \text{REFINE} \\
&= l_a
\end{aligned}$$

and C3 follows by

$$\begin{aligned}
({}^aX^b \oplus l_c) \cdot (l_b \oplus {}^aX^c) &= (l_{a \oplus b} \cdot_{R(a, b)} {}^1\mathbb{X}^1 \oplus l_c) \cdot (l_b \oplus l_{a \oplus c} \cdot_{R(a, c)} {}^1\mathbb{X}^1) && \text{DEF} \\
&= [l_{a \oplus b \oplus c} \cdot_{R(a, b, c)} ({}^1\mathbb{X}^1 \oplus \mathbb{1}_1)] \cdot [l_{b \oplus a \oplus c} \cdot_{R(b, a, c)} (\mathbb{1}_1 \oplus {}^1\mathbb{X}^1)] \\
&= [l_{a \oplus b \oplus c} \cdot_{R(a, b, c)} ({}^1\mathbb{X}^1 \oplus \mathbb{1}_1) \circ (\mathbb{1}_1 \oplus {}^1\mathbb{X}^1)] && \text{RSC, LR3} \\
&= l_{a \oplus b \oplus c} \cdot_{R(a, b, c)} {}^1\mathbb{X}^2 \\
&= l_{a \oplus b \oplus c} \cdot_{R(a, b \oplus c)} {}^1\mathbb{X}^1 && \text{REFINE} \\
&= {}^aX^{b \oplus c}
\end{aligned}$$

C4 follows from LR4 for  $k = 0$  and C5 by

$$\begin{aligned}
{}^aX^a \uparrow^a &= [l_{a \oplus a} \cdot_{R(a, a)} {}^1\mathbb{X}^1] \uparrow^a \\
&= l_a \cdot_{R(a)} ({}^1\mathbb{X}^1 \uparrow^1) \\
&= l_a \cdot_{R(a)} \mathbb{1}_1 \\
&= l_a
\end{aligned}$$

□

## Chapter 13

### **APPENDIX: The axioms for the algebra for flownomials**

Table 13.1: Algebra of flownomials

B1	$f \oplus (g \oplus h) = (f \oplus g) \oplus h$	B6	$l_a \oplus l_b = l_{a \oplus b}$
B2	$l_0 \oplus f = f = f \oplus l_0$	B7	${}^a X^b \cdot {}^b X^a = l_{a \oplus b}$
B3	$f \cdot (g \cdot h) = (f \cdot g) \cdot h$	B8	${}^a X^0 = l_a$
B4	$l_a \cdot f = f = f \cdot l_b$	B9	${}^a X^{b \oplus c} = ({}^a X^b \oplus l_c) \cdot (l_b \oplus {}^a X^c)$
B5	$(f \oplus f') \cdot (g \oplus g') = f \cdot g \oplus f' \cdot g'$	B10	$(f \oplus g) \cdot {}^c X^d = {}^a X^b \cdot (g \oplus f)$ for $f : a \rightarrow c, g : b \rightarrow d$

### I. Axioms for ssmc-ies (symmetric strict monoidal categories)

A1	$(\vee_a \oplus l_a) \cdot \vee_a = (l_a \oplus \vee_a) \cdot \vee_a$	A5	$\wedge^a \cdot (\wedge^a \oplus l_a) = \wedge^a \cdot (l_a \oplus \wedge^a)$
A2	${}^a X^a \cdot \vee_a = \vee_a$	A6	$\wedge^a \cdot {}^a X^a = \wedge^a$
A3	$(\top_a \oplus l_a) \cdot \vee_a = l_a$	A7	$\wedge^a \cdot (\perp^a \oplus l_a) = l_a$
A4	$\vee_a \cdot \perp^a = \perp^a \oplus \perp^a$	A8	$\top_a \cdot \wedge^a = \top_a \oplus \top_a$

A9	$\top_a \cdot \perp^a = l_0$
A10	$\vee_a \cdot \wedge^a = (\wedge^a \oplus \wedge^a) \cdot (l_a \oplus {}^a X^a \oplus l_a) \cdot (\vee_a \oplus \vee_a)$
A11	$\wedge^a \cdot \vee_a = l_a$

A12	$\top_0 = l_0$	A16	$\perp^0 = l_0$
A13	$\top_{a \oplus b} = \top_a \oplus \top_b$	A17	$\perp^{a \oplus b} = \perp^a \oplus \perp^b$
A14	$\vee_0 = l_0$	A18	$\wedge^0 = l_0$
A15	$\vee_{a \oplus b} = (l_a \oplus {}^b X^a \oplus l_b) \cdot (\vee_a \oplus \vee_b)$	A19	$\wedge^{a \oplus b} = (\wedge^a \oplus \wedge^b) \cdot (l_a \oplus {}^a X^b \oplus l_b)$

### II. Axioms for the additional constants $\top, \perp, \vee, \wedge$ (without feedback)

R1	$f \cdot (g \uparrow^c) \cdot h = ((f \oplus l_c) \cdot g \cdot (h \oplus l_c)) \uparrow^c$	(relating “ $\uparrow$ ” and “ $\cdot$ ”)
R2	$f \oplus g \uparrow^c = (f \oplus g) \uparrow^c$	(relating “ $\uparrow$ ” and “ $\oplus$ ”)
R3	$(f \cdot (l_b \oplus g)) \uparrow^c = ((l_a \oplus g) \cdot f) \uparrow^d$	(shifting blocks on feedback)
	for $f : a \oplus c \rightarrow b \oplus d, g : d \rightarrow c$	
R4	$f \uparrow^0 = f$	(no feedback)
R5	$(f \uparrow^b) \uparrow^a = f \uparrow^{a \oplus b}$	(multiple feedbacks)

### III. Axioms for feedback

F1	$l_a \uparrow^a = l_0$	F4	$\wedge^a \uparrow^a = \top_a$
F2	${}^a X^a \uparrow^a = l_a$		
F3	$\vee_a \uparrow^a = \perp^a$	F5	$[(l_a \oplus \wedge^a) \cdot ({}^a X^a \oplus l_a) \cdot (l_a \oplus \vee_a)] \uparrow^a = l_a$

### IV. Axioms for the action of feedback on constants

S1	$\top_a \cdot f = \top_b$	S3	$f \cdot \perp^b = \perp^a$
S2	$\vee_a \cdot f = (f \oplus f) \cdot \vee_b$	S4	$f \cdot \wedge^b = \wedge^a \cdot (f \oplus f)$

### V. The strong axioms ( $f : a \rightarrow b$ )

$$\text{ENZ}_E: \quad f \cdot (l_b \oplus y) = (l_a \oplus y) \cdot g \text{ implies } f \uparrow^c = g \uparrow^d,$$

where  $E$  is a class of abstract relations (i.e., of terms written with  $\oplus, \cdot, l, X$  and some constants in  $\top, \perp, \vee, \wedge$ ),  $y : c \rightarrow d$  is in  $E$  and  $f : a \oplus c \rightarrow b \oplus c, g : a \oplus d \rightarrow b \oplus d$  are arbitrary

### VI. The enzymatic rule